

AUTO•PRO Plus AP-Plus I • AP-Plus II

AUTOMATIC NUMBERING, PERFORATING & SCORING MACHINE

INSTRUCTION and PARTS MANUAL



**COUNT
MACHINERY COMPANY**

MADE IN U.S.A.
CE Approved

_____ AP-Plus I _____ AP-Plus II

Serial No.: _____

Model: _____

Voltage: _____

Inspected: _____

TABLE OF CONTENTS

SPECIFICATIONS.....	1
SAFETY PROCEDURES/CARE & MAINTENANCE.....	2
COMPONENT IDENTIFICATION	3
SET UP INSTRUCTIONS	4
TOUCH SCREEN CONTROLLER	5
Perf Mode.....	6
Feeder Mode.....	7
Number Mode.....	7
Transport Operation.....	8
Programming for Number Mode	9
Saving/Recalling Custom Jobs.....	10
Batch Counter.....	11
FEED TABLE ASSEMBLY	12
ADJUSTING FEED GUIDES	13
Squaring the Rail Bases	13
Replacing Feed Wheels.....	14
PAPER CALIPER ASSEMBLY	15
Height Adjustment for Paper Thickness	15
Adjusting the Paper Retard Spring	16
Changing the Stationary Wheel	16
Feeding Notes.....	17
Checking the Sensor	17
PERF SHAFT & STRIKE PLATE ASSEMBLY	18
PERFORATING & SCORING ASSEMBLIES	19
Gripper Wheel Perf-Score Mounting Diagram	20
Scoring Assembly Diagram.....	21
NUMBERING HEAD	22
Depressing a Wheel	23
Changing Direction of Head	23
Function of Head Brackets	24
Adjusting the Vertical Bracket	24
Adjusting for a Level of Impression	25
Tips for Leveling Head	25
Setting the Action Indicator/Repeat Selector	26
Replacing the Repeat Selector	27

INK CARTRIDGE	28
TROUBLESHOOTING	29
SERVICE DIAGRAMS	30
A - Side Frame Left	30
B - Side Frame Right	31
C - Inner Side Frames and Base	32
D - Feed Table/Entrance View	33

ELECTRICAL SPECIFICATIONS

Power Requirement: 115V, 60 HZ, AC
 Circuit Protection: Motor/Transformer 3 AMP Circuit Breaker
 Microprocessor 1/4 AMP Slo-Blow
 Pulse Board 3 AMP Slo-Blow

NOTE: Older buildings, overloaded lines and bad grounds can effect the operation of your Auto•Pro Plus. A dedicated line is best.

OPERATING SPEEDS

MODE	Transport Speed (Feet per Sec.)	11x17 Sheet (est)	5 1/2" Sheet (est)
AP-Plus I & AP-Plus II			
Perf Mode	2.0	8,500	12,500
Number Mode	2.0	6,200	7,800

SPECIFICATIONS

Net Weight: AP-Plus I 125 lbs
 AP-Plus II 130 lbs
 Overall Dimensions: 47"Lx27"Wx17"D
 Boxed Dimensions: 34"Lx32"Wx17"D
 Min Sheet Size: 4"x4"
 Max Sheet Size: 18"x20"
 Stock Weight: Numbering 16 lb. Bond to 8 Part Carbonless
 Perf & Score 16 lb. Bond

NOTE: The AP-Plus is capable of handling many types of applications above and beyond the standard specifications. It is possible to feed quite a variety of jobs, from fold over saddle stitched booklets to envelopes and even die cut stocks. However, the performance of the Auto•Pro Plus on these special applications is directly related to the experience of the operator.

SAFETY PROCEDURES

BEFORE USE...

- Read through the owner's manual. Follow instructions CAREFULLY.
- Never use in a wet area. Electric shock could occur.
- Use a Grounded outlet and Grounded circuit. Do not use ungrounded equipment on the same circuit.

DURING USE...

- Keep fingers and hands away from numbering head.
- Keep cords clear of moving parts.

AFTER USE

- Turn off the machine at the rear panel, then unplug the main power cord.
- To unplug cords, Always grasp the plug body, Never pull on cords to disconnect. Wire fatigue and possible shock could result from improper disconnect procedures.
- Unplug power cords Before cleaning the numbering wheels.

BE ALERT! BE CAREFUL!

CARE AND MAINTENANCE

The Auto Pro Plus is a precision machine. It is very important to keep it free of excessive dust, dirt and foreign matter. We recommend that you keep the machine covered when not in use.

BEARINGS:

The bearings are sealed roller bearings and are designed to be self lubricating, however, dirt and dust can get into them causing clogging and dirt build up. It is recommended to occasionally oil them under heavy use.

NUMBERING HEADS:

Keep your numbering heads clean with Count Clean & Lub.

To clean: Remove numbering head and place it in a small container with enough solution to just soak the numbering wheels. Stand the head upright so that the solution does not enter into the electronics. Brush wheels lightly, pat dry or blow dry with a compressor. Do this periodically to insure clean impressions.

DO NOT USE BLANKET WASH!

RUBBER ROLLERS:

These tend to harden when exposed, and in use, use "Count Rubber Rejuvenator" on all rubber rollers and stationary roller often. Preferably after each day of use or more. "Do not use Blanket Wash or Other Cleaners."

STRIKE PLATE:

This area should be cleaned periodically using a silicone spray (3M or comparable). This area should be slick, not dry and tacky.

SENSOR EYE:

Clean the upper and lower sensor with a Q-tip (avoid moving the sensor to clean). Clean when necessary.

REMOVABLE SCREWS: (i.e. Head Bracket, Head Mounting Screws, Perf Shaft Screws)

When these show signs of wear or stripping, replace as soon as possible. If these strip or hollow out they can be costly to remove! If you keep you Auto Pro Plus clean and in top condition, it will give you years of service.

COMPONENT IDENTIFICATION

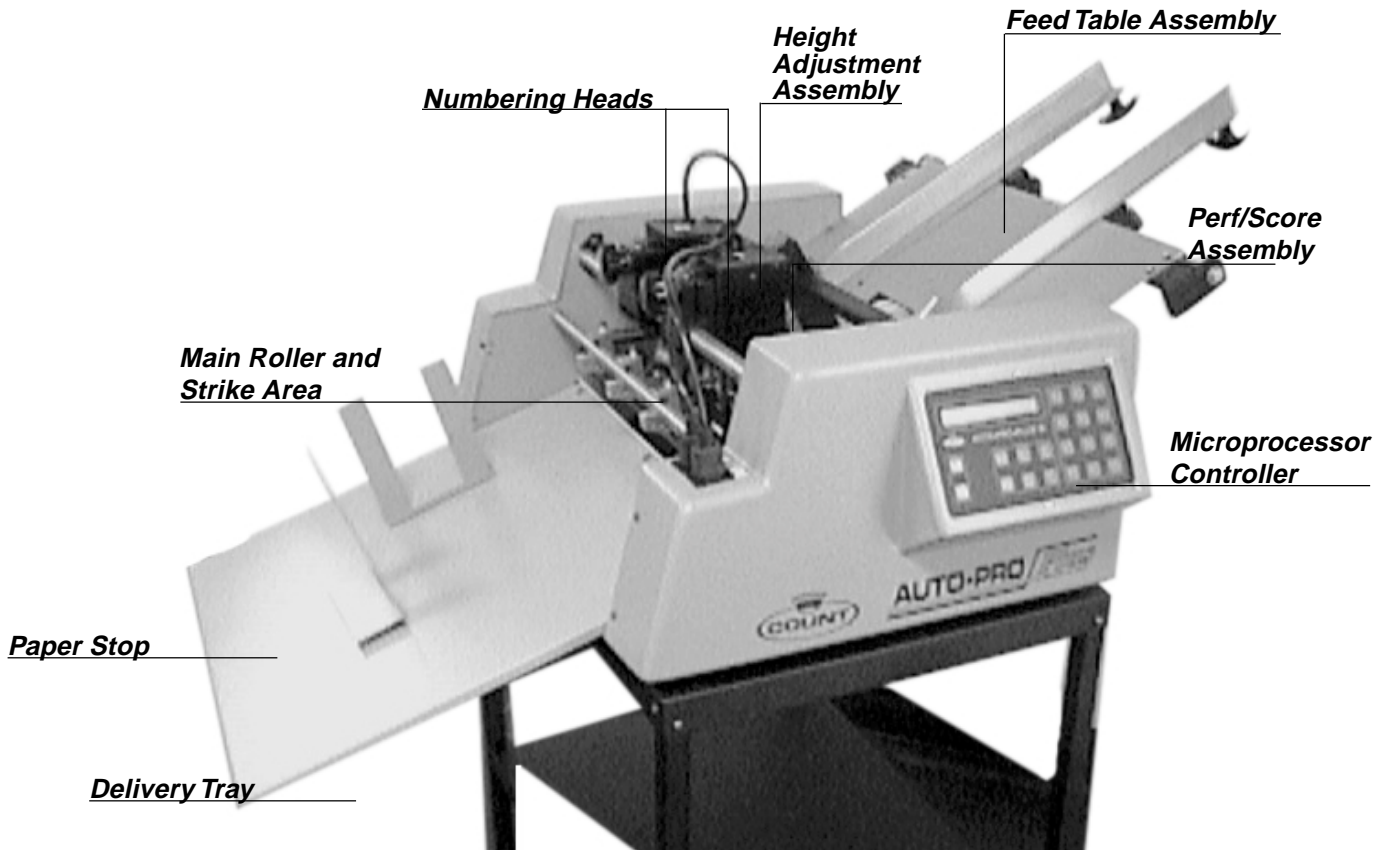

REFERENCES

Microprocessor Controller	Pg. 5
Adjusting Feed Guides	Pg. 11
Height Adjustment	Pg. 13
Paper Caliper Assembly	Pg. 16
Perf Shaft & Strike Plate	Pg. 17
Perf/Score Assemblies	Pg. 20
Numbering Heads	Pg. 20

SETTING UP YOUR AUTO•PRO PLUS

Section 1

1. Open top half of box and remove components.
2. Place machine on table with enough room in front and behind the delivery tray and feed table to be installed.
3. Unscrew feed rail guide shaft, slide shaft out. Place feed rails on feed table and slide shaft back in going through feed rail guide brackets.
4. Place delivery tray in front so tray sets on steel dowels directly below the lower perf shaft. Locate the magnetic paper stops and position them on the tray.
5. Inspect the remaining parts and place them near the machine where they are easily accessible.
6. Plug in your machine. NOTE: The Auto•Pro Plus requires only 115V so any standard outlet will accommodate it. However, it is important that the line has a good ground. Also make sure the circuit is not overloaded with other equipment, as this will cause erratic behavior in the computer due to line spikes and current drops.

AUTO PRO TOUCH SCREEN CONTROLLER

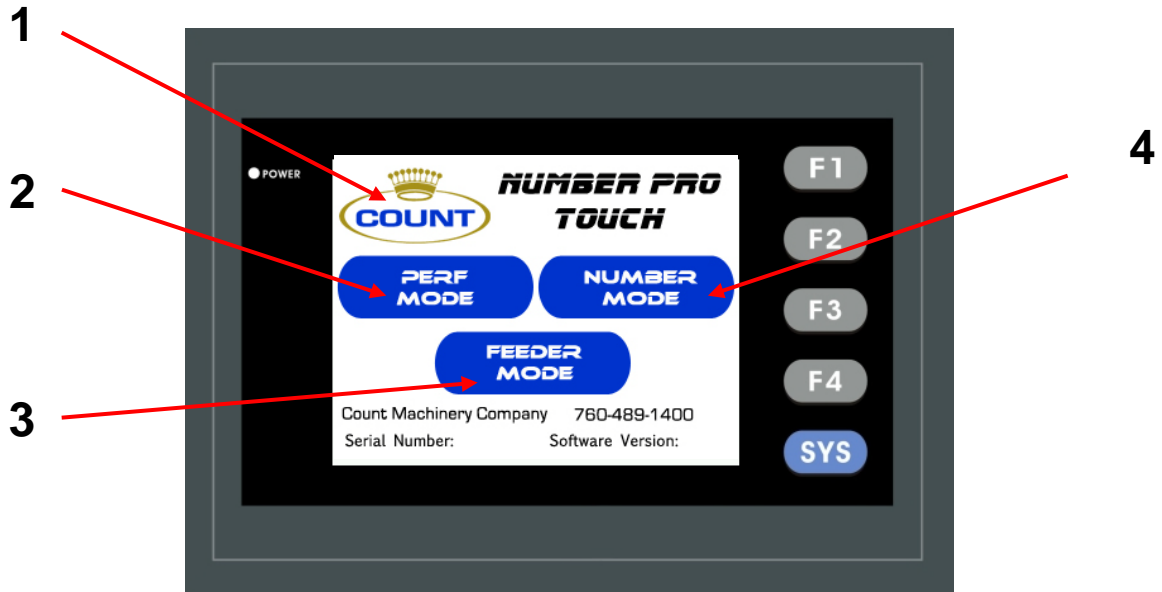

THE TOUCH SCREEN CONSISTS OF FOUR SECTIONS:

1. Count Logo and Service Access
2. Perf Mode
3. Feeder Mode
4. Number mode

*** SPECIAL NOTE NONE OF THE F KEYS OR SYS KEY TO THE RIGHT ARE USED.**

Touch Screen Operation

When the machine is turned on the display may take up to 7 seconds for the home screen to display. There is a screen saver that will turn the display off if the machine is not touched within 30 minutes. The power light will stay illuminated letting you know the machine is still on.

Count logo and Service Access

If the logo is pressed a password screen is displayed. This is for factory and service access only. This Screen is for internal use only. The password is not given out.

Perf Mode

From the home screen press the perf mode button the perf mode screen will be displayed.

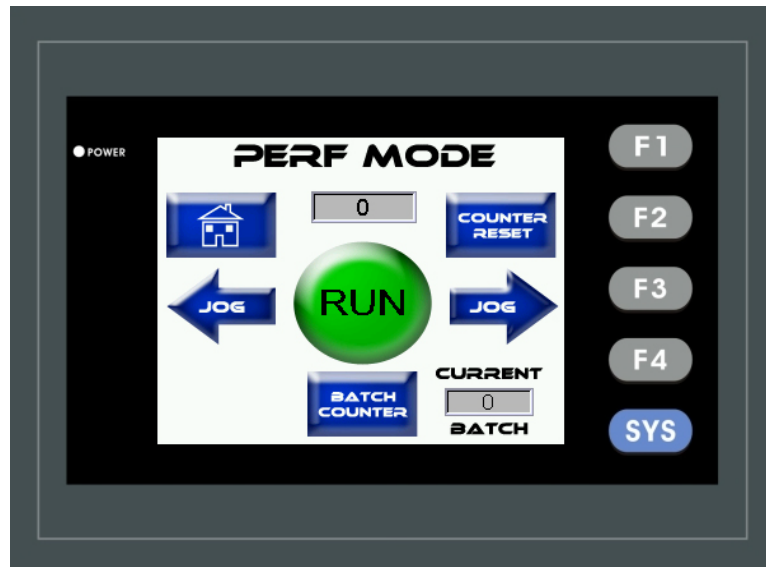

Home: Takes you back to the home screen.

Counter Reset: Resets the displayed counter to 0.

Jog Left and Right: Slowly advances the rollers left or right.

Batch Counter: Allows for stopping the machine after a batch number is reached.

Run: Turns on the transport and starts the feeding of paper.

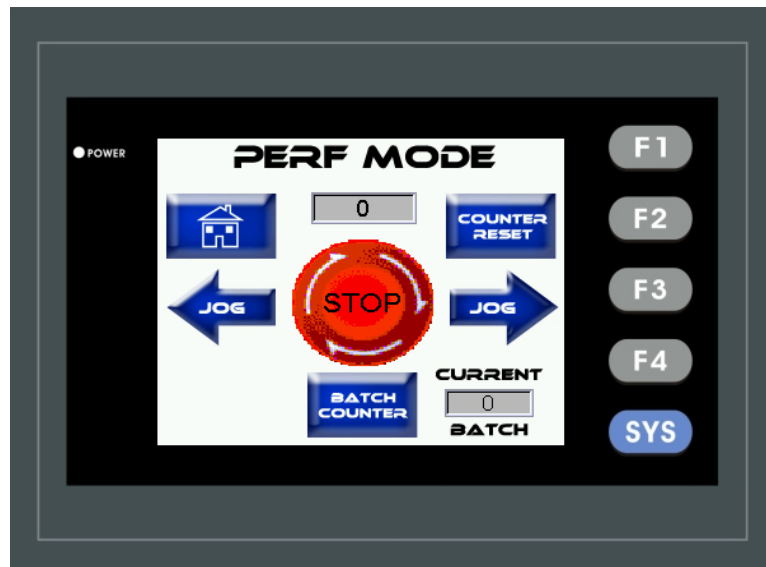

When the Run Button is pressed the Graphic will change red and the button will flash.
This is the indicator the machine is in running.

Feeder Mode

Feed mode is the mode to run your NUMBER PRO TOUCH as a feeder into our CountCoat UV Coater. It runs much slower than the other modes giving the sheets enough spacing to move through the UV coater.

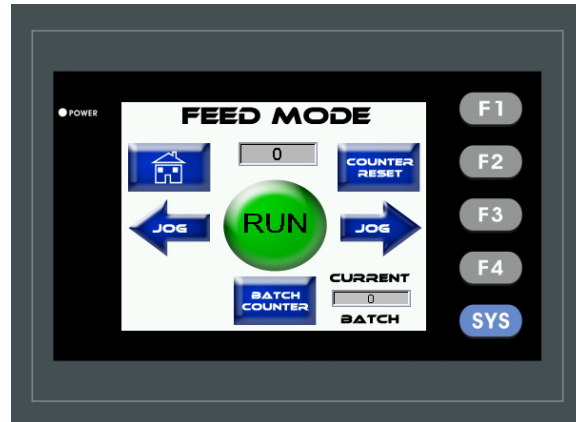

Home: Takes you back to the home screen.

Counter Reset: Resets the displayed counter to 0.

Jog Left and Right: Slowly advances the rollers left or right.

Batch Counter: Allows for stopping the machine after a batch number is reached.

Run: Turns on the transport and starts the feeding of paper.

Number Mode

Number mode is used to apply a numbering impression to a piece of paper. In this mode enter the positions and what number head you would like to use for that position.

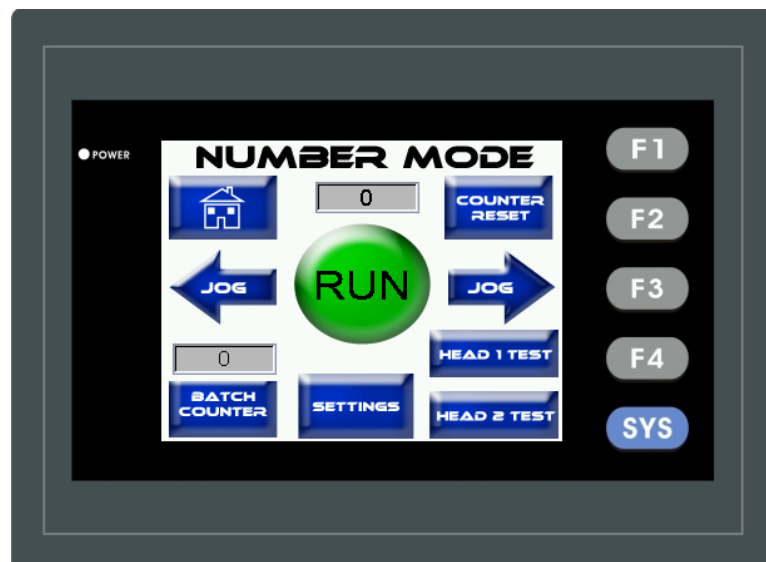

TRANSPORT OPERATION



- The Run Button will start the Transport in any given mode. Press it again to stop the transport. Each Mode has a timeout feature to preserve the life of the machine.

- A document may be slowly advanced through the transport by pushing and holding one of these buttons.



EXAMPLE:   

The motor should advance transport at slow speed and stop whenever finger is lifted.

- Controls on-off function of motor.

EXAMPLE:  

Machine will run at mode and speed previously selected.

- Machine will stop.  

PROGRAMMING FOR NUMBER MODE

In Numbering Mode it is important to understand how to program the positions. The machine must be programmed in order from the lead edge of the sheet. Each Position can fire Head 1, Head 2, or Both.

Press the Number Mode Button > Positions > 1 Position > Enter in Position > Select Head 1, 2, or Both > Accept > Run.

EXAMPLE:

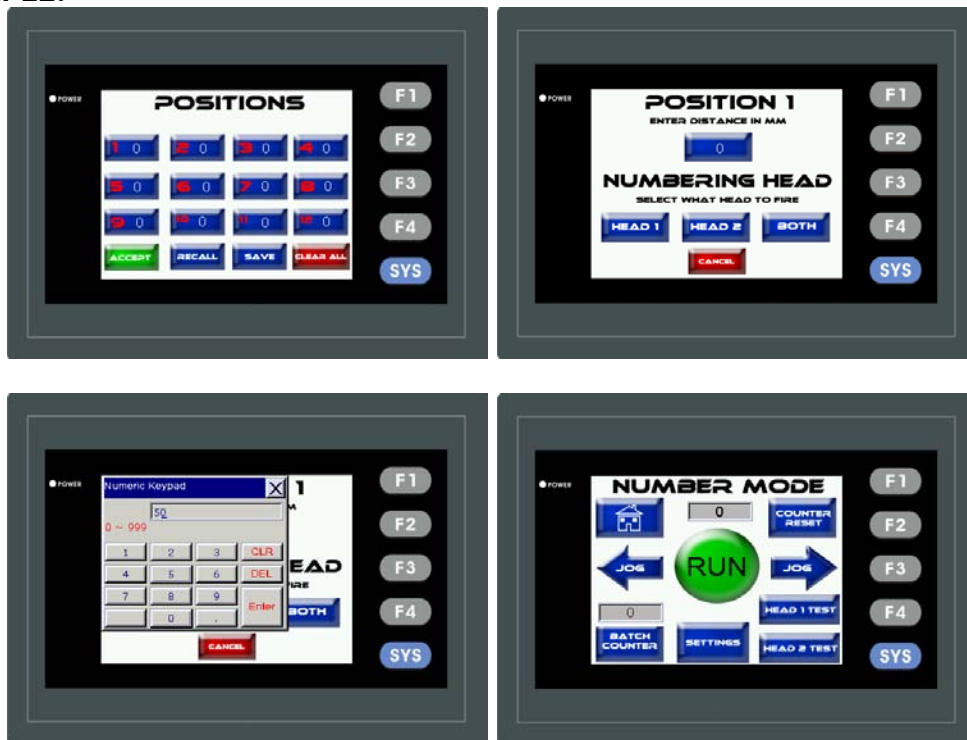

Saving Numbering Jobs: Press the Number Mode Button > Enter In Distance For each Position in mm > Select Head > Save > Select Location to save in 1, 2, 3, or 4.



Recalling Numbering Jobs: Press the Number Mode Button > Recall > Selection the Program Number > Accept > Accept > Run.

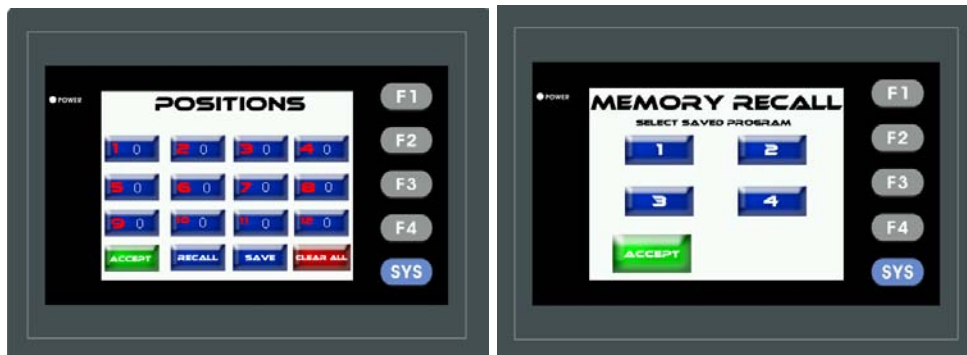

Batch Counter: Press the Batch Counter button from the run screen in any mode and it will take you to the Batch Count Screen.

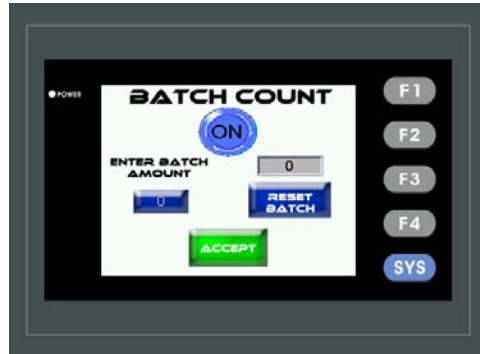

Press the Enter Batch Amount Button to enter in the number you want to run per batch.

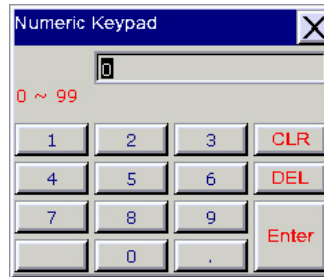

Press the Reset Batch Button to start from 0. Press the On Button. The button turns red as shown below.

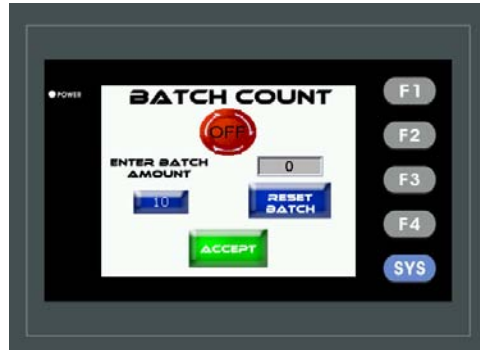

As you are running and the batch number is reached the screen will display " Batch Complete.

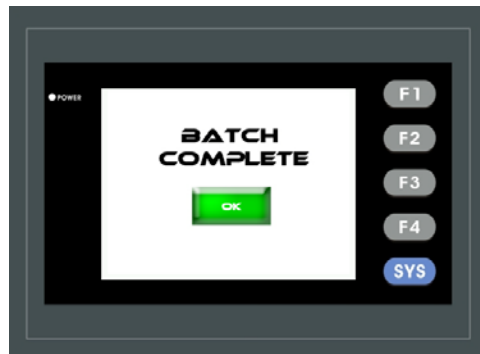

FEED TABLE ASSEMBLY

Feed Rail Alignment Knob

Nut Adjustment Feed

Micro-Lateral Lock

Feed Rail Assembly

Feed Rail Lock Down

Feed Wheel Rollers



Feed Wheel Rollers - H-0410

Rubber rollers advance sheets to the main roller.
***This is a replaceable part**

Nut - Adjustment Feed - F-0640

Micro-Lateral Adjustment Lock - F-0645

When positioning is correct, this will lock the Adj. Knob in position.

Feed Rail Assembly - Left - S-AAM-0540
Feed Rail Assembly - Right - S-AAM-0530

Guides paper into transport.

Feed Rail Alignment Knob - H-0840
(Knob T w/ 1/4"-20 thread)

Releases and tightens feed rails to adjust for Perf and Score alignment.

Feed Rail Lock Down - H-0840
(Knob Assembly)

Releases and tightens feed rails to adjust for different size jobs.

ADJUSTING FEED GUIDES

The feed guides on your Auto Pro-Plus are designed to adjust easily in case of a problem with crooked feeding. By loosening the feed rail alignment knobs you can move each rail independently to square them to your stock. To maintain an accurate Perf or Score it is important to get the rails as aligned and snug to the sheet as possible without “squeezing” the sheet, as this will create drag and cause the sheets to hang up in the rails.

To adjust this correctly, use one rail as your reference, the left (operator side). Place your stock squarely against it then bring your right rail in and tighten, looking down it from the rear. Adjust this so it is squared to the sheet. Then tighten alignment knob, and place your Auto Pro-Plus in Perf mode. Press run, and set sheet in feeder, check Perf by folding over Perf edge.

Perf holes should line up within a blade’s width. If they do not line up, adjust rails accordingly, moving your left rail first and then adjusting the right rail to square the sheet. This may take a few attempts, but this adjustment is important to produce quality Perf and Score jobs.

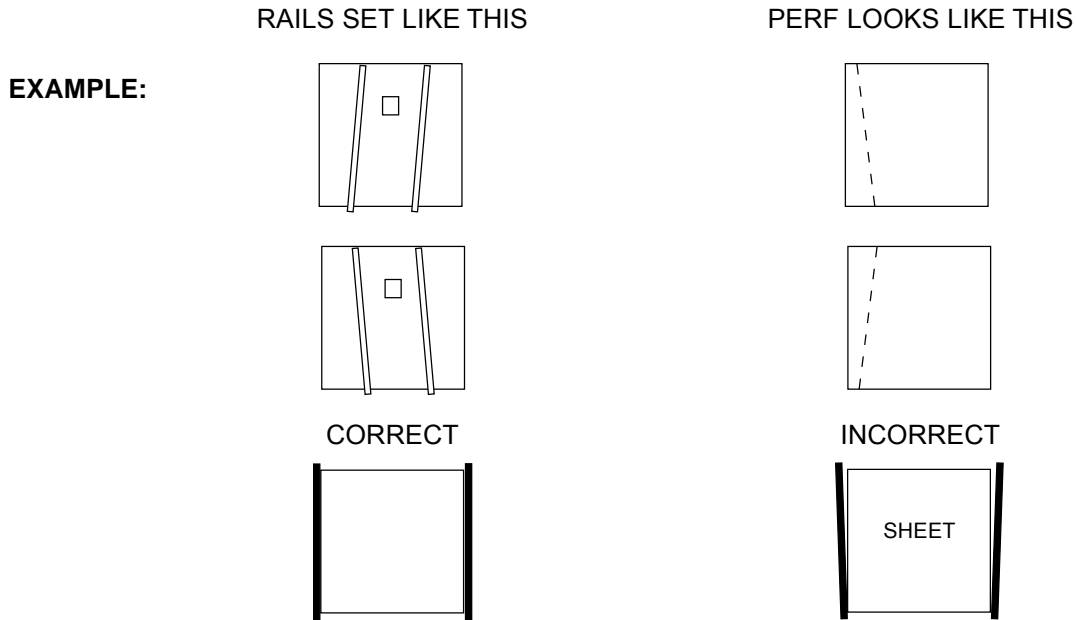

SQUARING THE RAIL BASES

The rail bases are set square at the factory, however, it is possible for these to get bumped or knocked out of alignment. When these are properly squared (or aligned) it is easier to adjust your feed guides to accurately register while perforating or scoring. If your feed table is dropped or bumped it will be necessary to square these yourself. To do so, loosen the feed rail alignment knob. Lift the upper portion of the feed rail slightly and slide it over (see photo); not the 2 allen screws that secure the rail base to the feed rail mounting block. Loosen these slightly then replace the upper rail and tighten the knob. Make sure the upper base 2 base are aligned with each other (centered). Then place an 8 1/2" x 11" chip board between the rails and press the 11" side edge of the chip board against the rail which has not been upset. Now move the rail to be adjusted against the chip board. Tighten the feed rail, lock down and gently push the feed rail base so it is parallel to the edge of the chip board. When you have done this, lift the upper rail up and over to expose the 2 allen screws. Tighten them and replace upper rail. If both rails have been upset, you can remove the feed table and use a large T-square. Squaring each rail to the lead edge of the feed table.

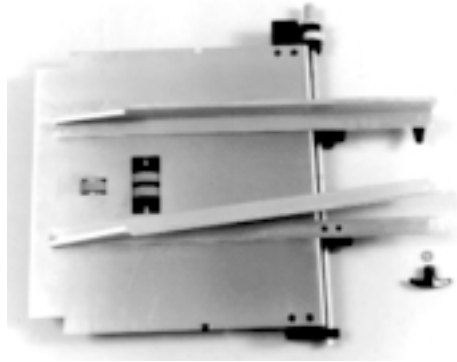

REPLACING FEED WHEELS

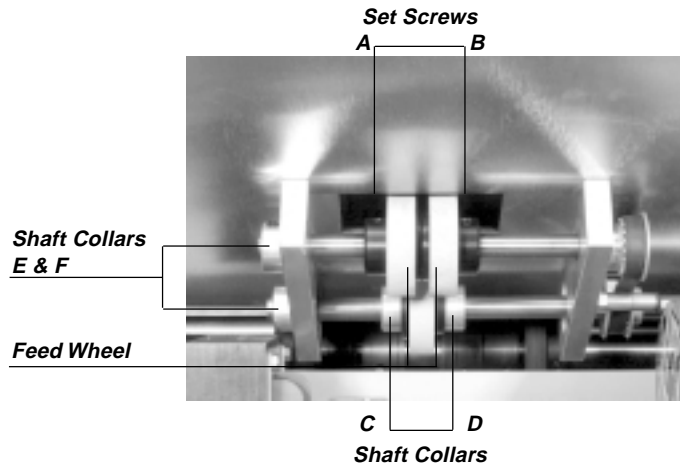

1. First remove the two rear feed wheels. (NOTE: DO NOT LOOSEN ANY PULLEYS FROM SHAFTS.) To do this, remove shaft collars (E&F).
2. Loosen set screws (A&B), then slide shaft out remove feed wheel hubs and replace rubbers rollers.
3. Loosen shaft collars (C&D).
4. Remove the side cover that the numbering heads plug into.
5. Loosen the two belt tension brackets (item 1a & b Idler Pulley Assy.), and remove belts. (NOTE: DO NOT LOOSEN ANY PULLEYS FROM SHAFTS.)
6. Remove motor drive belt (item #2) do this by rotating pulley and pulling on drive belt at same time, thus allowing the belt to walk off the pulley.
7. The front feed roller shaft can now be removed allowing feed roller hub to be removed. (NOTE: This hub has a directional bearing in it and will spin freely only in one direction. Be sure to install this hub in the same direction that it is removed or the feed table will not feed the sheets through the transport.
8. Reassemble in the same order for that it was removed.

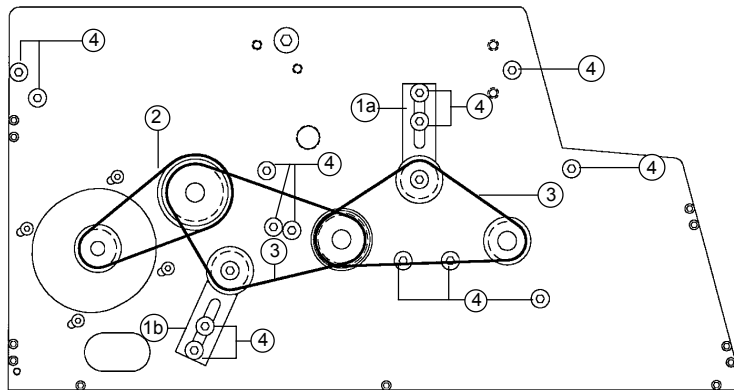

Description

Part

- | | | |
|----|---|------------|
| 1. | a. Idler Pulley Assy. | S-APP-0646 |
| | b. Idler Pulley Assy. | S-APP-0645 |
| 2. | Belt, Timing - 1/5 pitch 110xL037 | H-0704 |
| 3. | Belt, Timing - 1/5 pitch 140xL037 | H-0700 |
| 4. | 1/4-20x3/4 Socket cap bolt | H-0315 |

PAPER CALIPER ASSEMBLY

Height Adjustment Knob

Height Adjustment Lock

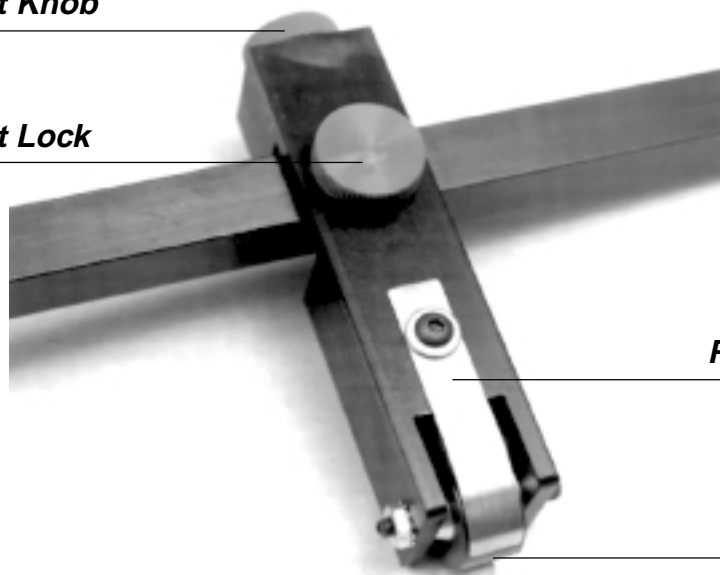

Paper Retard Spring

Stationary Wheel

Height Adjustment Knob - S-AAM-0610	Raises and lowers stationary roller to adjust for paper thickness.
Height Adjustment Lock - S-AAM-0600	Locks the height adjustment assembly in position after correct setting is achieved.
Travel Adjustment Lock-Down - H-0225	Locks the height adjustment assembly for 1/4" of travel up and down by the stationary roller. (Not shown in this picture)
Paper Retard Spring - FS-340	Fans stack and works with stationary roller to correctly space sheets for feeding and prevent jamming.
Stationary Roller (Std.) - S-AAM-0580	Rubber wheel which is adjusted to the paper thickness. This wheel does not turn! (This is a replaceable part.)
Stationary Roller (Soft) - S-AAM-0590	Rubber wheel which is adjusted to the paper thickness. This wheel does not turn! (This is a replaceable part.)

HEIGHT ADJUSTMENT FOR PAPER THICKNESS

To adjust this for your job, turn your Auto Pro-Plus on and start the transport. Loosen the height adjustment lock. Hold a sheet under the Caliper Assembly and using the height adjustment knob lower the assembly until you feel a slight pull. The stationary wheel should be barely touching the sheet. While still holding the sheet under the stationary wheel, tighten the lock slightly making sure the adjustment does not change. Stop transport. With the transport off, push a sheet under the assembly again. Take a second sheet and try to push it under the assembly. IT SHOULD NOT GET PAST THE STATIONARY ROLLER.

If it does, release the lock and turn down the assembly very slightly and try the "Second Sheet Test" again. When this is set, place 10 to 20 sheets in the feeder. Fanning them is not required. Press advance and the stack should fan itself! Advance the first sheet out to the main roller then stop. Now press run. The sheets should move through the transport with approximately a 1" gap between them. If you get a double, place the stack in the feeder again and as the Auto Pro-Plus is running, loosen the lock and adjust slightly until the 1" gap is achieved.

ADJUSTING THE PAPER RETARD SPRING

The paper retard spring is critical to the correct operation of a friction feed system. As you can see on the diagram, it is important that the spring contacts the stationary wheel and curves under it slightly. If the spring gets bent out away from the wheel, this will cause problems with doubles and sheet spacing. The height is adjustable by loosening screw B and moving it up or down slightly.

If feed problems occur, they are generally due to improper setting of the retard spring or a worn or flat spotted Stationary Roller. Note that the retard spring should contour the Stationary Roller and extend down. Point C should be slightly higher than point D. When a flat spot occurs, this places point C lower than point D which will cause doubles as the Stationary roller loses contact.

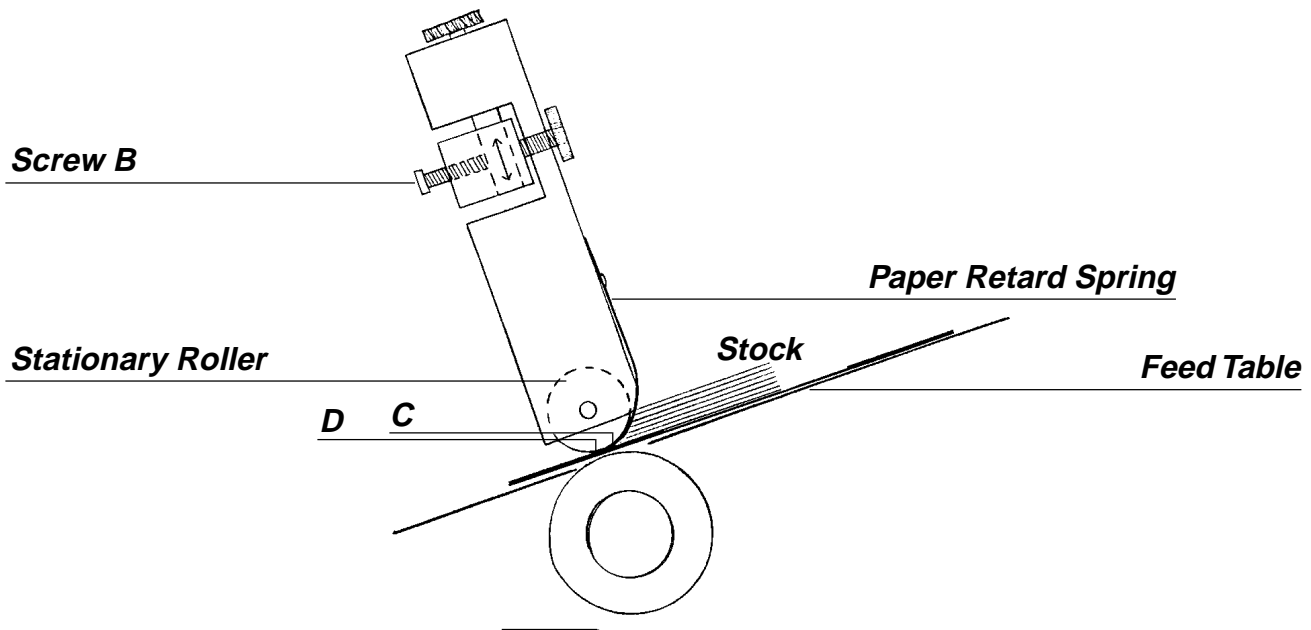

CHANGING THE STATIONARY WHEEL

A stationary wheel is a replaceable part. After use it will develop flat spots and should be turned frequently so paper is always being presented to a point, not a flat spot. If you are having a problem with doubles on thinner stocks try switching these. This is very simply done by removing the wheel bolt and replacing the wheel. Be sure to tighten the bolt securely as this wheel should not turn.



FEEDING NOTES

- When set properly, the friction feed is very efficient and flexible. When neglected it can become very frustrating to run even the simplest job. The adjustments previously discussed are very important as well as keeping the feed wheels CLEAN and tacky. We recommend you use Count Rubber Rejuvenator.

DO NOT USE BLANKET WASH!

- The Auto Pro-Plus is capable of running 14 lb. single sheets, 6 part forms and 80 lb. cover. Its flexibility is directly related to the operators experience.

- When setting up a numbering job, it is best to find the easiest way to feed the job. Then set up accordingly. For example, carbonless sets almost always feed best from the open edge. The glued edge tends to curl and cause problems with doubles as well as fold over on delivery. Also, the open edge is usually the shorter direction which consequently runs faster.

- Once your job is in progress, you can add paper to the feeder without stopping the transport. This will take a little practice as the tendency at first is to put the stack in with the weight forward, this could cause a double feed, but with practice you will figure out how to set the additional stock in with the weight to the rear. You will also notice that not all jobs are able to feed with the same pile height. An 8 1/2" x 14" two part carbonless form requires less weight on the stack to feed through properly, where as an 8 1/2" x 11" four part can stack twice as high.

- There are two types of stationary wheels available. The silver core is the standard wheel which works best on carbonless sets and many other stocks. The black core is a softer wheel and works better on thin stocks, 14 to 20 pound bond, stock certificates, etc... But will try to separate sets.

- All carbonless sets are fed into the Auto Pro-Plus with as little pressure from the height assembly as possible.

CHECKING THE SENSORS

1. Turn machine power on and allow "startup count down mode to complete".
2. At this time your display on your control board should read "AUTO PRO AP-2+" or "1" if AP1.
3. By placing a sheet of paper between the sensors your control board should read "SENSOR BLOCKED"
4. By removing paper between sensors display should return to default menu "AUTO PRO AP-2+".
5. If above steps all work correctly sensor is working properly, if not, contact C.N.M. service department.

PERF SHAFT & STRIKE PLATE ASSEMBLY

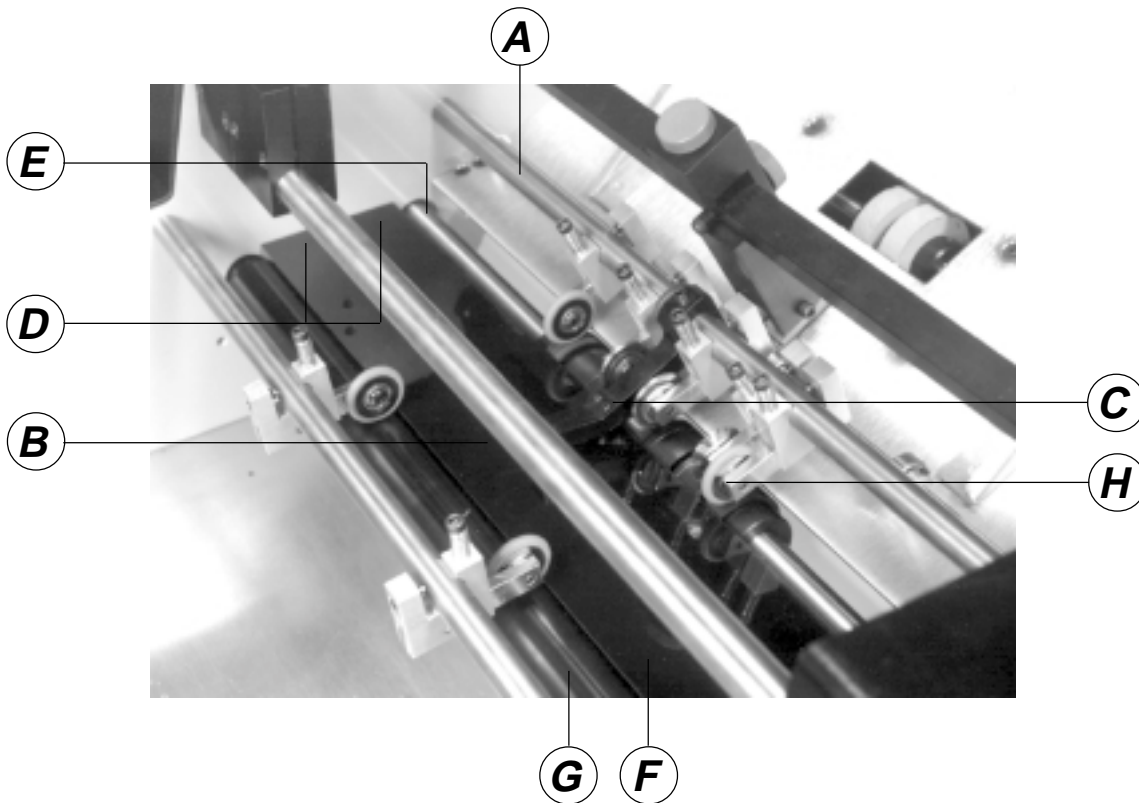

- | | |
|--|---|
| A - Support Bar - F-0232 | This is the shaft that the upper sensor is mounted on along with the roller wheels and perf score. |
| B - Lower Sensor Eye Assy. - S-AAM-0230 | Located in the platen strike plate, directly below the upper sensor. These two must align. |
| C - Upper Sensor Assy. - S-APP-0210 | Houses the upper sensor and is adjustable. The sensor is used to detect the leading and trailing edges of each sheet as it moves through the transport. |
| D - Strike Plate Bolts - H-0295 | These bolts (1/4-20 x 1/2 socket cap bolt) hold the strike plate assembly to the unit. |
| E - Perf Shaft Assembly - S-APP-0158 | Steel roller, primary source of contact for stock to contact and advance through the transport. This is where the paper is perforated and scored. |
| F - Strike Plate Assembly - S-APP-0701 | This is the numbering surface. It is made of a platen plastic designed to give slightly to absorb the impact of the numbering head. |
| G - Burr Roller Shaft - S-APP-0112 | This is the exiting roller of the machine that helps to ensure accurate registration, straight perforating and scoring. |
| H - Roller Wheel Assembly | These urethane wheels are mounted to a bracket with a pressure screw, designed to place pressure on the stock while passing over the rollers. |

PERFORATING AND SCORING ASSEMBLIES

For removing an old blade and attaching a new blade to the pressure adjust mounting bracket, remove the (1) Button Head Allen Cap Screw. **BE SURE TO TIGHTEN THE SET SCREW SECURELY TO THE BAR.** Once you have the Upper and Lower Perf Assemblies in place, you can tighten the Half Dog Set Screws.

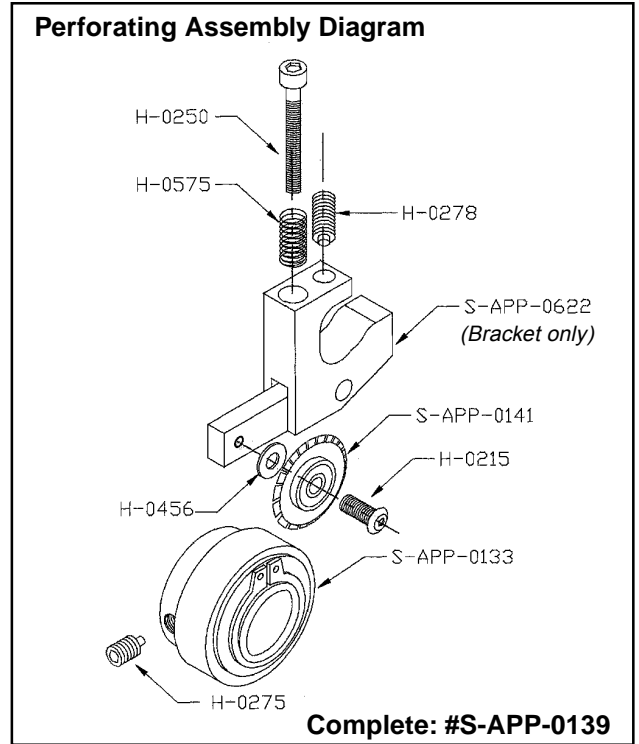
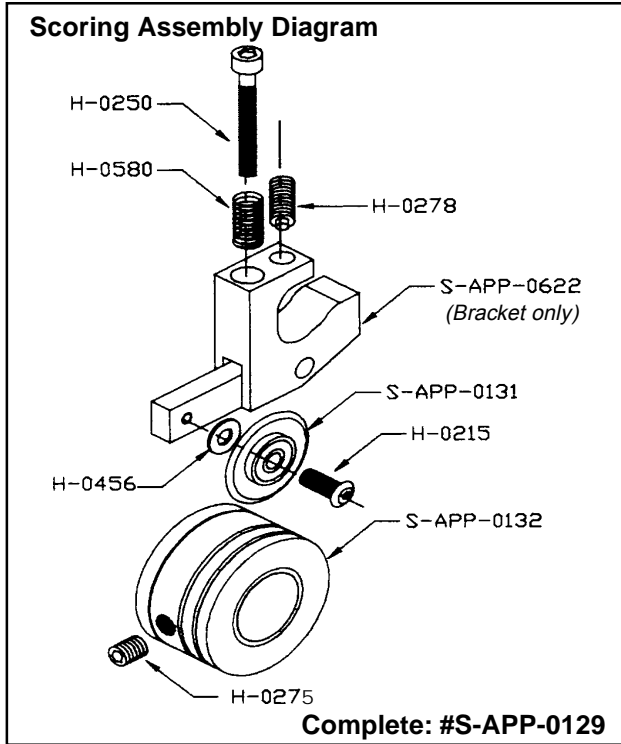

Part No.	Description
H-0215	Screw - 10-32x1/2" Button Head Socket
H-0250	Screw - 10-32x1/2" Socket Cap
H-0275	Screw - 1/4-20x1/4" Socket Set
H-0278	Screw - 1/4-20x1/4" Socket Half Dog
H-0456	Washer - Flat .200
H-0580	Compression Spring 1 1/2"
F-0403	315-S40 Silicone Gripper Wheel
F-0425	Forward Roller Mount - AP-APP
F-0430	Forward Roller (Rubber Only)
S-APP-0116	Roller Wheel Assembly
S-APP-0131	Score Blade Assembly
S-APP-0143	Perf Blade Assembly (9-1)
S-APP-0144	Perf Blade Assembly (12-1 CE only)
S-APP-0160	Micro Perf Assy Complete w/ Hub
S-APP-0132	Lower Score Assy. Hub - APP
S-APP-0133	Hub Perf Auto Pressure
S-APP-0622	Bracket - Perf/Score Pres. Adj. Assy.

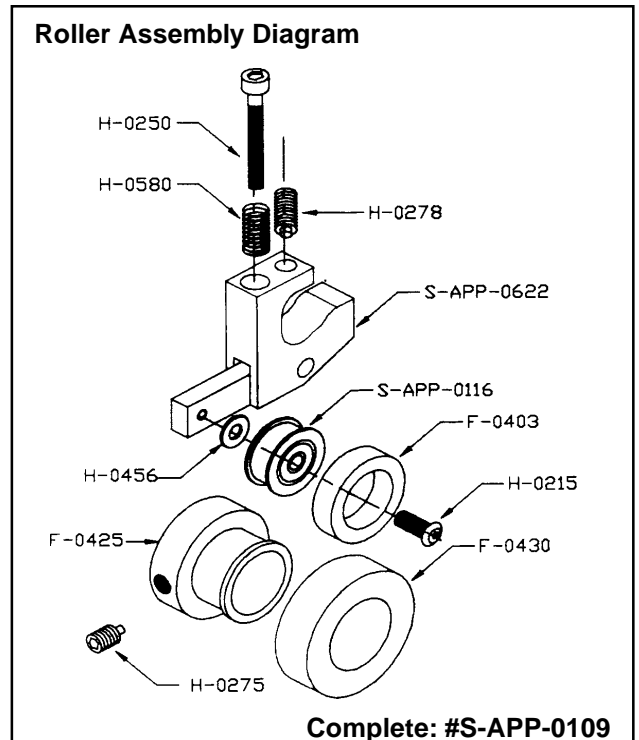

GRIPPER WHEEL PERF-SCORE MOUNTING

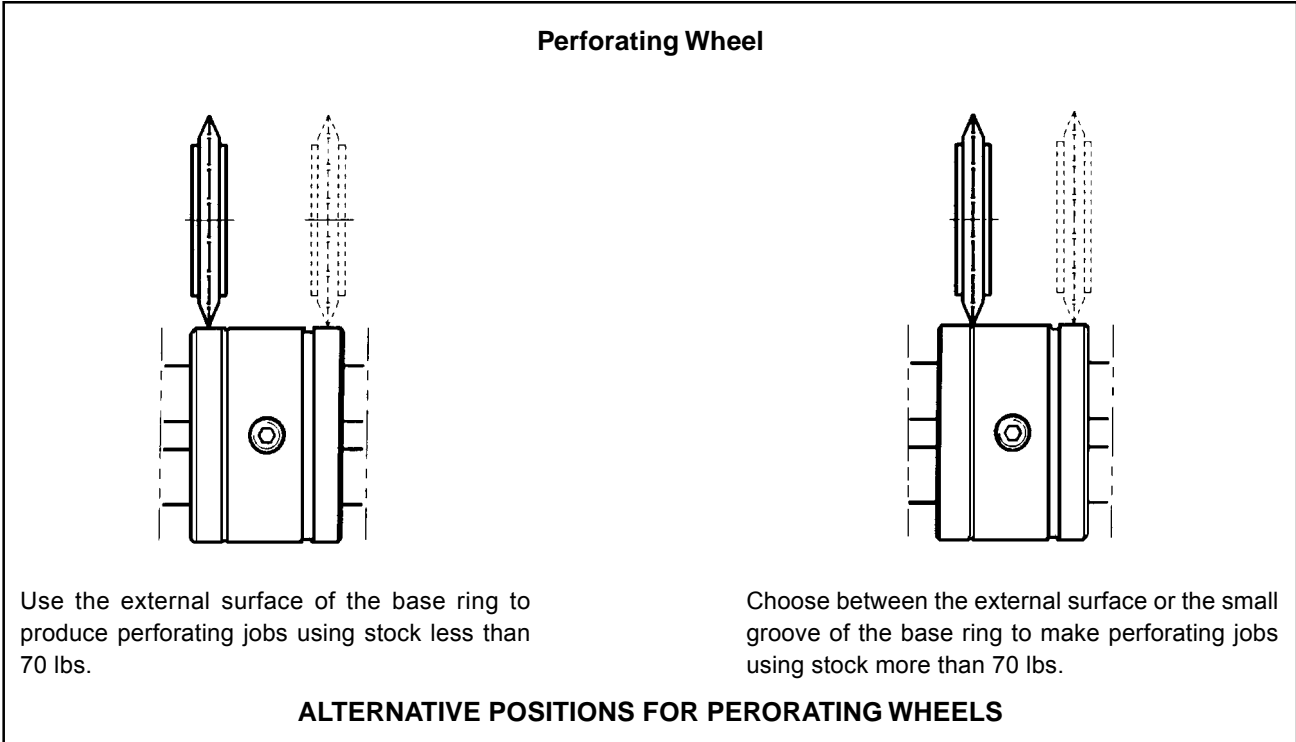
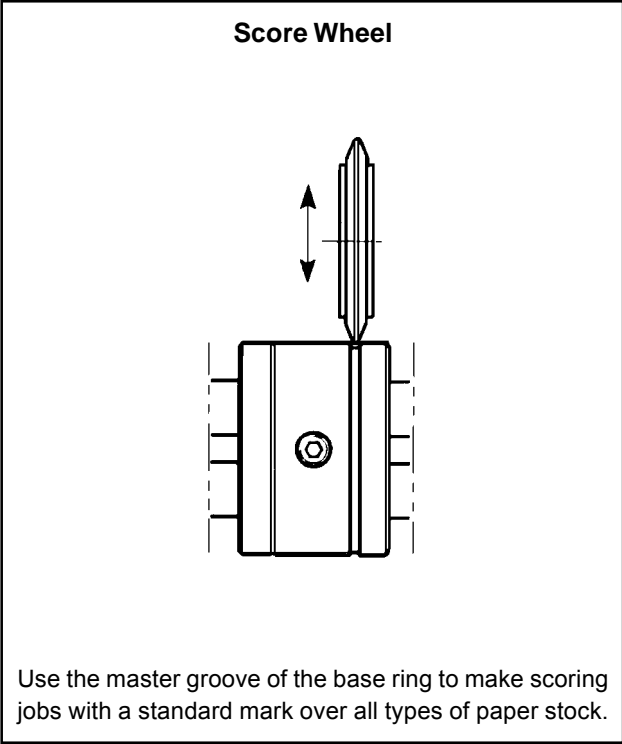
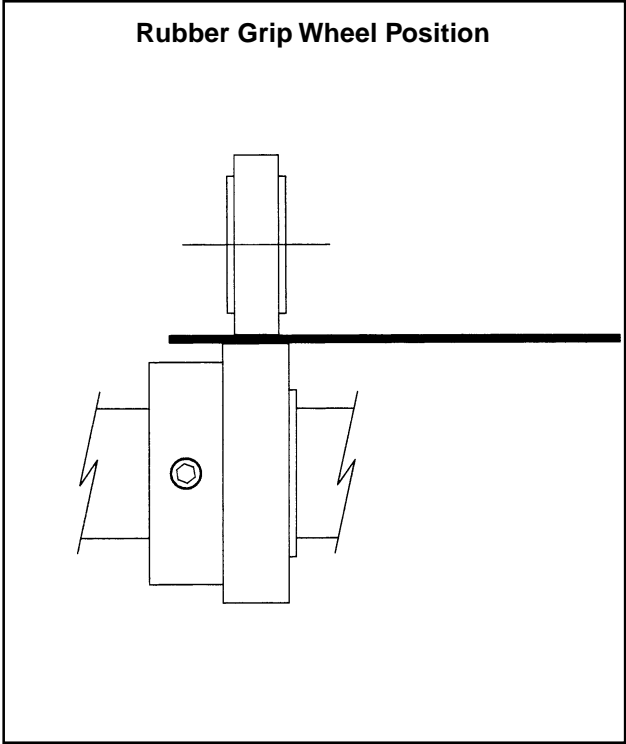

SCORING

Position your score blade as desired. Scores should be made so that the blade runs on the side of the sheet that will be on the inside of the finished fold. Scores may be made on the Auto-Pro plus in three different ways.

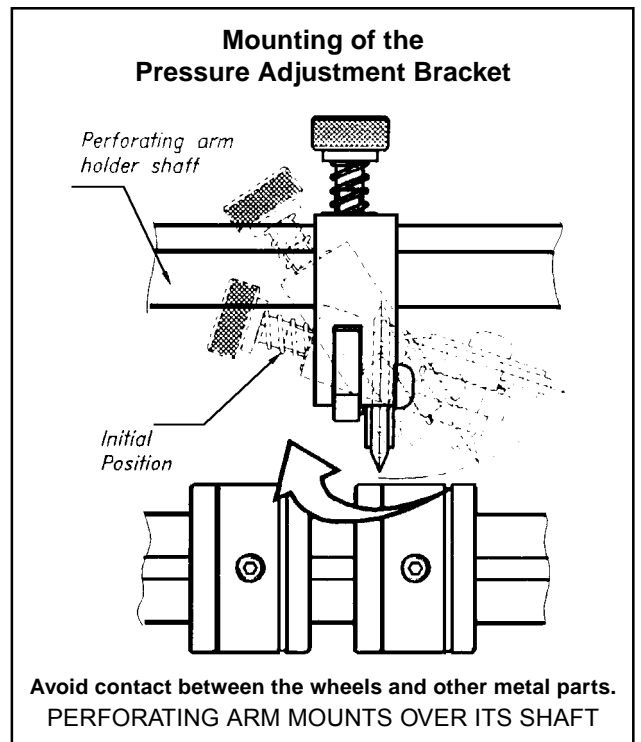
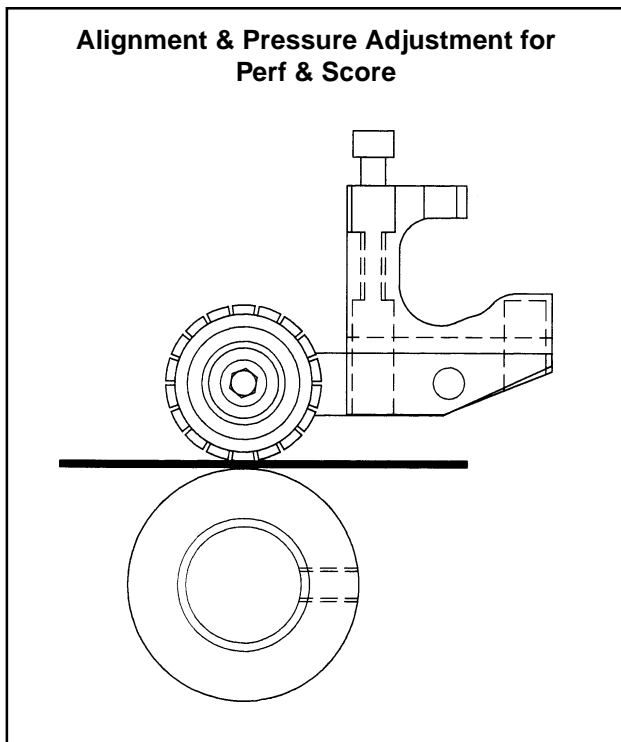
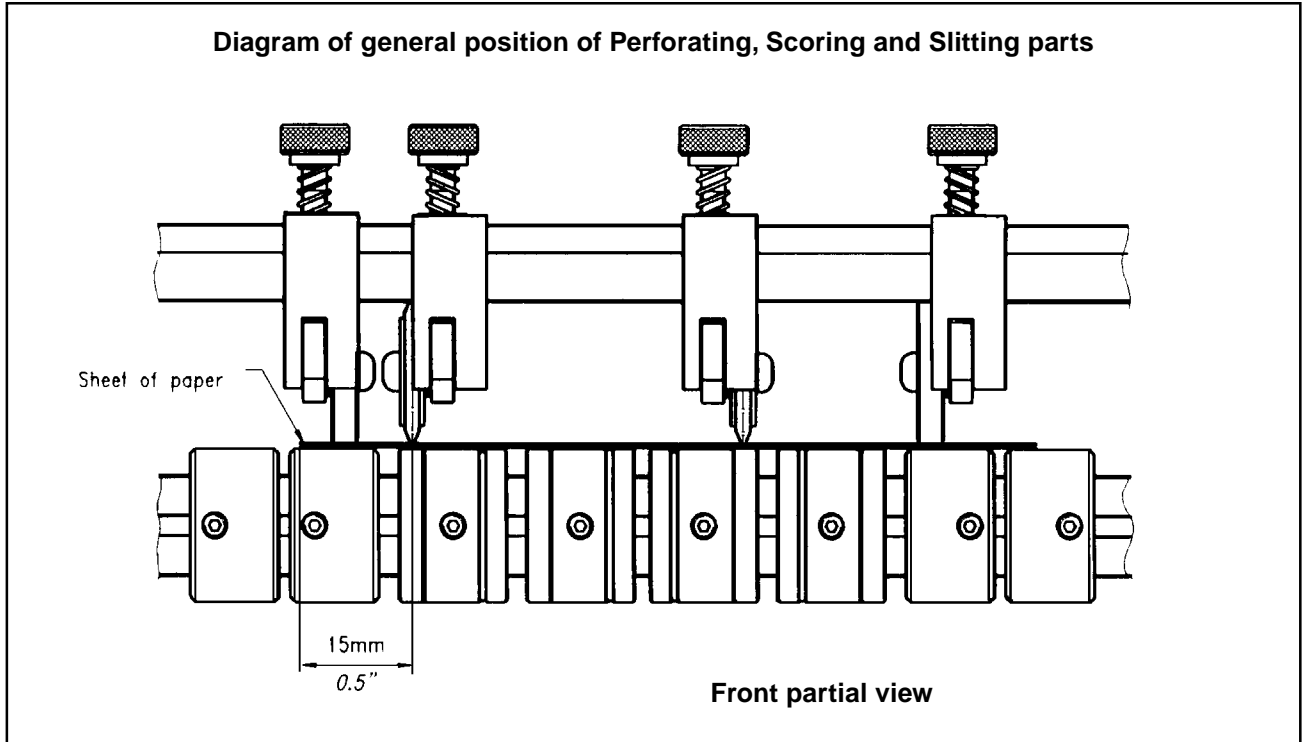

NUMBERING HEAD

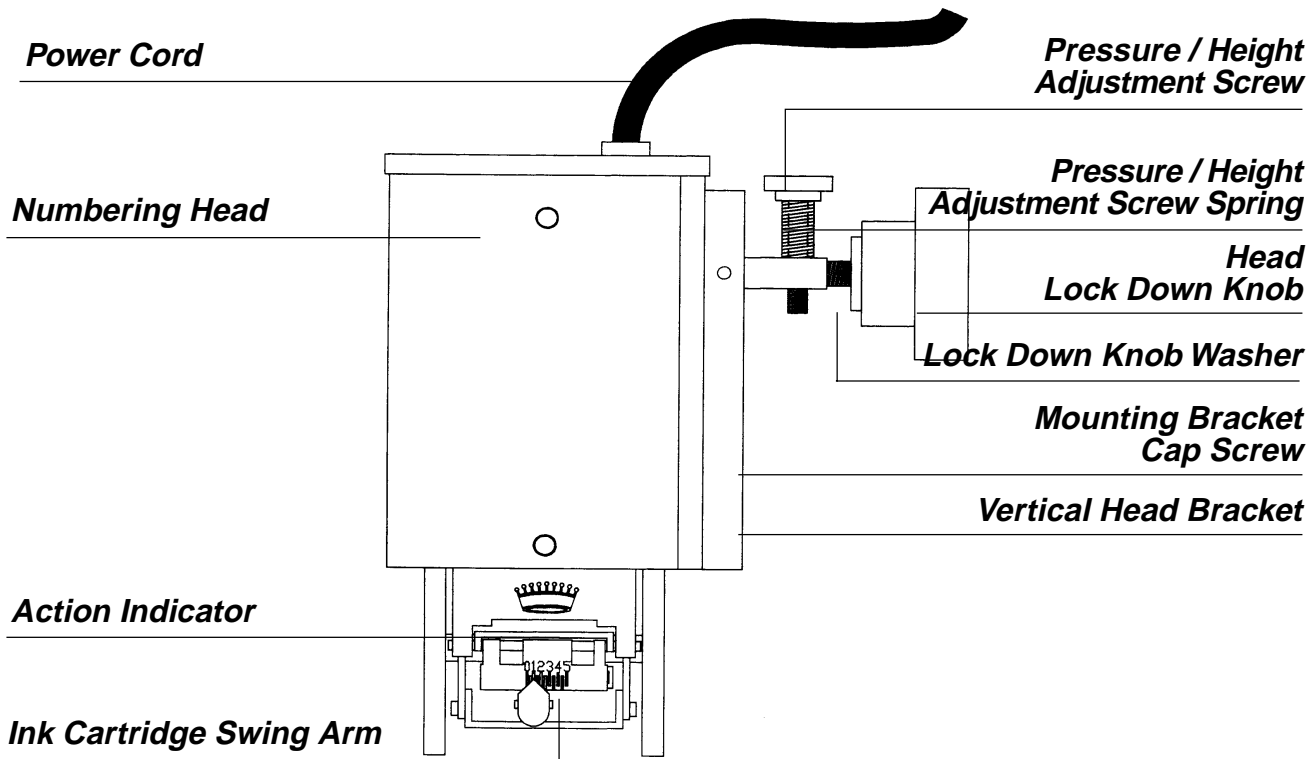

Numbering Head - H-1125
(Standard 6-Wheel)

The Numbering Heads can be operated simultaneously and can be rotated any direction in 90° increments.

Head Mounting Bracket - F-0466

Mounts Head to machine and slides from side to side to position Head in desired position.

Mounting Bracket Cap Screw - H-0225

Tightening this locks bracket onto position.

Vertical Head Bracket - F-0500

Mounts to the side of the Numbering Head and positions the head into the head of the Mounting Bracket.

Vertical Head Bracket Assy. - S-AAM-0800

Complete assembly includes: F-0500, H-0475, H-0835, and H-0575.

Pressure / Height Adjustment Screw - S-AAM-0620

This screws into the Vertical Head Bracket Stem to adjust the pressure of the strike of the head.

Pressure / Height Adjust. Screw Spring - H-0575

This spring is necessary to retain the setting of the screw.

Head Lock-Down Knob - H-0835

Tightend the Head Assembly to the Mounting Bracket.

Lock-Down Knob Washer - H-0475

Installs with the Lock-Down Knob.

Power Cord - E-0975

Plugs into receptacle on side of Auto Pro Plus.
NOTE: This is not a 110V line. DO NOT plug into a wall socket to test.

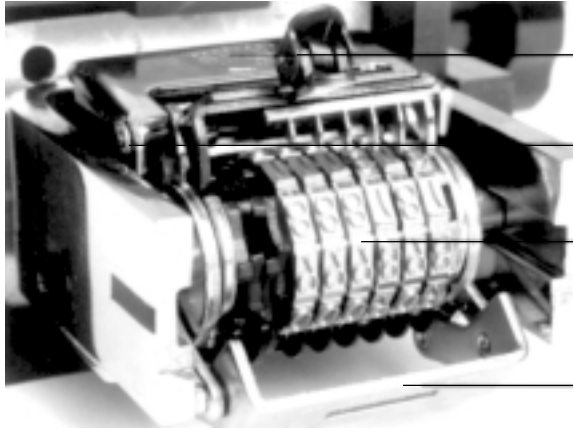

**Action Indicator/
Repeat Selector**

**Action Indicator
Shaft & C Clip**

**Wheel
Assembly**

**Ink Cartridge
Swing Arm**

Action Indicator/
Repeat Selector - S-AAM-0870

Wheel Assembly - H-1125

Ink Cartridge
Swing Arm - S-UNS-0912

Action Indicator
Shaft & C-Clip - H-1176

DEPRESSING A WHEEL

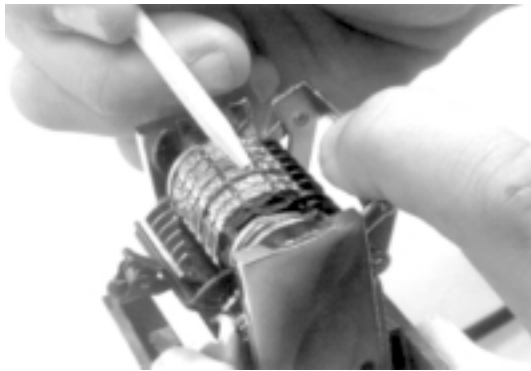

The standard Numbering Head is capable of recessing the first three wheels so there is no image when striking. For example, to print the number 4750 instead of 004750, you will need to depress the first two wheels. To do so, remove the Numbering Head from the Head Bracket and hold it upside down resting it on a flat surface.

Swing the Ink Cartridge away from the wheels (or remove). Rotate the 1st wheel until the 9 is in the up position. Then press forward slightly and down, you will feel the wheel depress below the level of the others. Do the same to the 2nd wheel. Now you can print a 4 digit number. To return to position, simply rotate the wheel and it will pop up. This feature is also available on the custom Numbering Wheel with letters. Rotate the wheel until the blank position is up then press forward and down.



CHANGING DIRECTION OF THE HEAD

The Numbering Head is capable of turning 360 degrees in 90 degree increments. To change the direction, simply remove the Vertical Bracket (using the 5/32 T- Wrench Supplied) and reinstall on the desired side. NOTE: To get to the Upper Mounting Screw for the Vertical Bracket, you must remove the Lock Knob and Pressure Adjustment Screw first. Take notice of how far the Adjustment Screw extends below the Stem so that when replacing you have a reference point. When replacing the

Pressure Adjustment Screw, compress the spring slightly before trying to screw in the Adjustment Screw. This is a very fine thread and can easily be started incorrectly leading to thread damage. Do not try to press the Spring in with the Adjust Screw and turn at the same time.
(Trust Us!) See photo.

FUNCTION OF HEAD BRACKETS

For direction purposes we will call the mounting of the Vertical Bracket. In this position:

PARALLEL

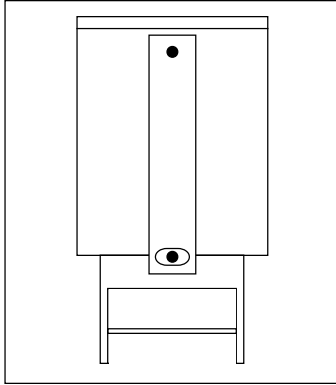

VERTICAL

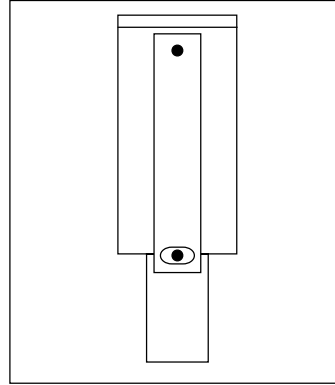

It is important to be familiar with the adjustment of the brackets. Shown below are the various adjustments and the effect they have on the image of the number.

Depending on the orientation of the head the adjustment of the Vertical Bracket can be either:

In the Parallel Position:
LEFT TO RIGHT

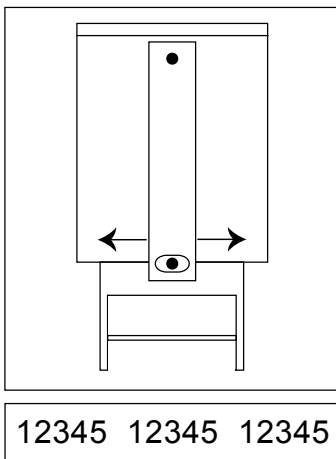

In the Vertical Position:
TOP TO BOTTOM

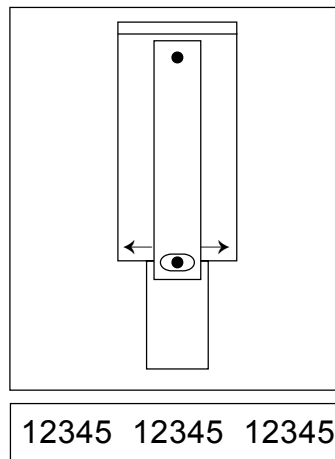

OR

ADJUSTING THE VERTICAL BRACKET

The bottom of the vertical bracket is slotted to allow for movement. The effect of this movement depends on the orientation of the head (See Function of Head Brackets). To make an adjustment to the vertical bracket, simply loosen the lower screw and slide toward the direction desired, then retighten the screw. It is not necessary to loosen the top screw.

ADJUSTING FOR A LEVEL IMPRESSION

To begin the leveling process, move your numbering head's to the desired lateral position on the bar. To do this you must first loosen the mounting bracket cap screws (item #1.) Then loosen the head lock down knob (item #2.) When these are both released, the head and bracket will slide along the bar. By using your horizontal adjust screw (item #3.) Along with your vertical adjust pressure screw (item #4.) Thus allowing for fine adjustment to pressure as well as levelness prior to tightening lock down knob and mount bracket cap screws. You are now ready to number.

TOP TO BOTTOM

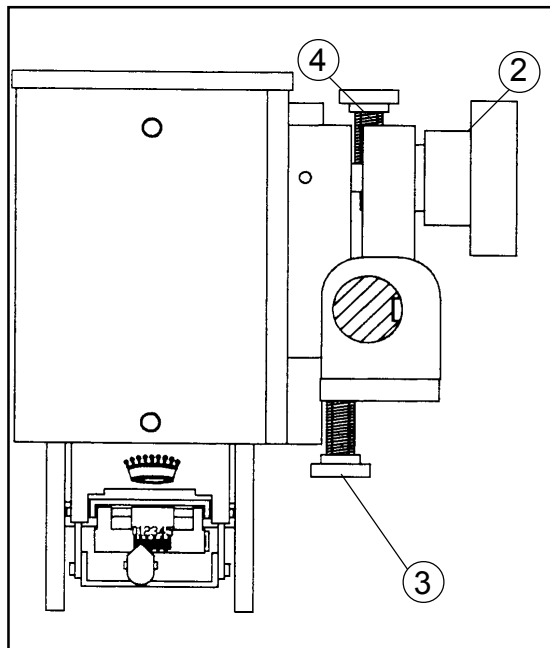

LEFT TO RIGHT

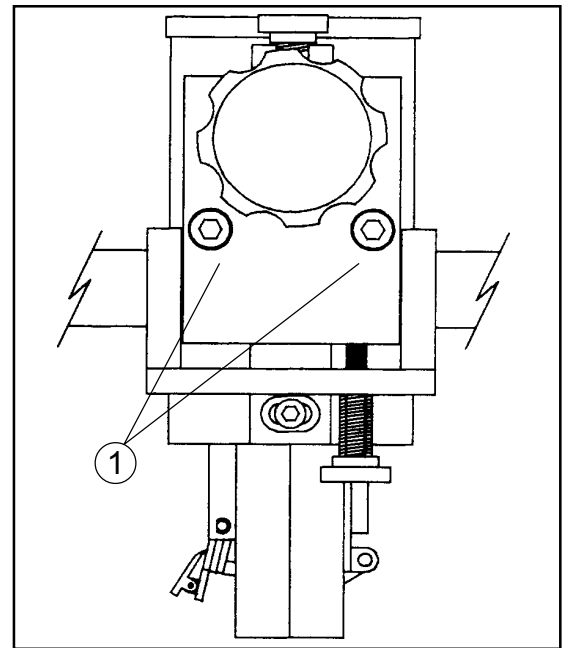

TIPS FOR LEVELING HEAD

Leveling the numbering head is the most critical part of the set up process. If the head is not level you will get a blurred or "Ghosted" Impression. This can also occur when the head is set to hit too lightly or too heavy. Never set pressure to favor the drop wheels, for this will depreciate the life of the numbering wheels. The easiest way to check your impression is to use a 3 part carbonless set. Program the Auto Pro Plus to stamp in one location anywhere on the sheet. Run your test sheet through the machine and check impression for pressure as well as levelness. By level we mean a level impression. Where the impression of the 1st digit is the same pressure and impression as the 5th and 6th digit always favoring the 1st digit slightly. And the top of the digits is the same as the bottom. We do not mean "plumb level," as using a small level will not help.

SETTING THE ACTION INDICATOR/ REPEAT SELECTOR

This allows you to select the number of times that the head will strike without advancing to the next number.
EXAMPLE: If you need to number a job which requires the same number in two (2) positions, slide the selector to "2." The head will now strike the same number twice.

NOTE: After selecting a repeat sequence, replace head and run a test sheet through the Auto Pro-Plus.

You should get this:

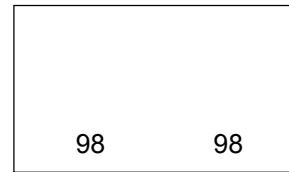
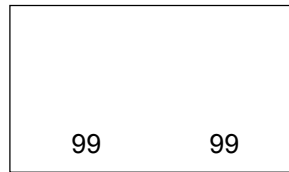
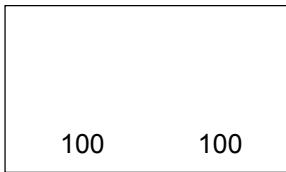

If you get this:

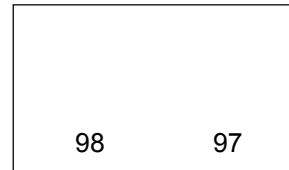
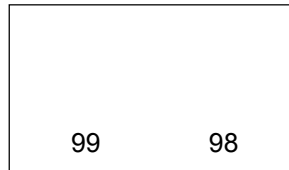
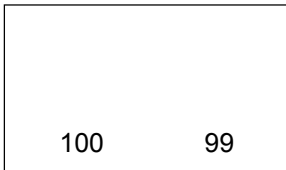

the number changes at the wrong strike, the wheel cam is not in sync with the paper. To remedy this, you must get the head to fire 1 time. This can be done by programming in a single strike and running a sheet through or run a sheet through with the existing program and quickly unplug the head after the first strike. Once you have achieved a single strike the cam is now in the correct changing sequence.

REPLACING THE REPEAT SELECTOR (ACTION INDICATOR)

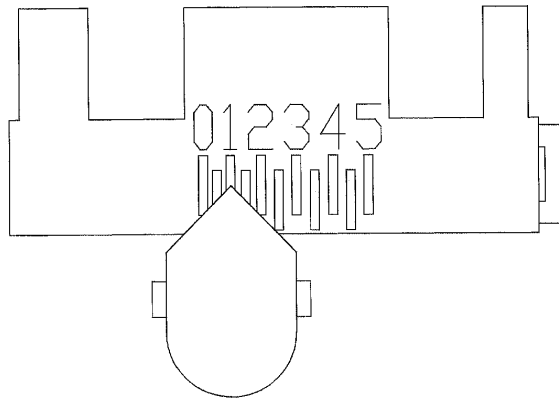

First, remove the “C” clip from either end of the shaft and slide shaft out. The spring will sometimes catch on the end of the shaft. If the shaft gets hung up, use your needle nose pliers to jiggle the spring and pull the shaft out. Place the new selector in position and place the new springs in their location, making sure the springs are in their guide holes. Slide the new shaft through and place “C” clips on each end.



Removing the “C” clip

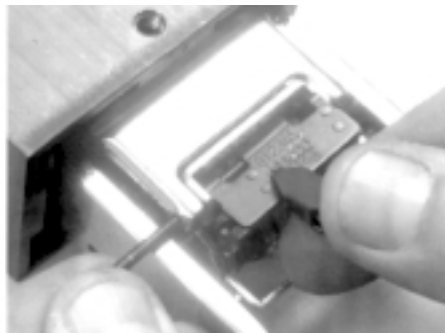

Replacing the shaft



Installing the new springs

Now, with your needle nose pliers, pull the spring ends lightly until it stops, bend end of spring over and cut off excess wire. This will tighten the return action of the selector.



INK CARTRIDGE

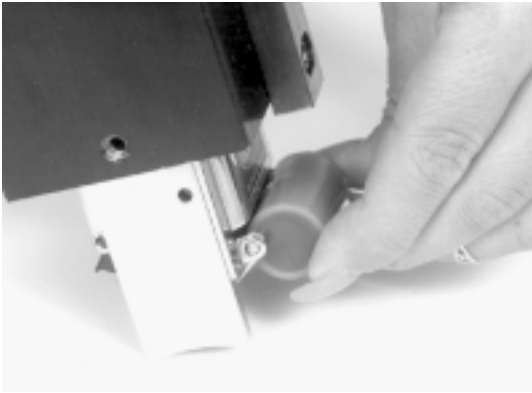

Photo A

The ink cartridge slides under the swing arm and locks into place. (Photo A) When installing a new ink cartridge, first remove the foam pad using an x-acto knife and place a small cut into the reservoir (Photo B). This will supply ink to the foam through the action of the swing arm. Start with a small hole as it is easier to make the hole larger, but if you start with the hole too large you cannot control the flow of the ink.

NOTE: The flow of ink can be sensitive to temperature. On a cold day the ink will be thicker and not flow easily, whereas on a hot day the ink will be thin and flows faster. Also, be sure to shake cartridge well.

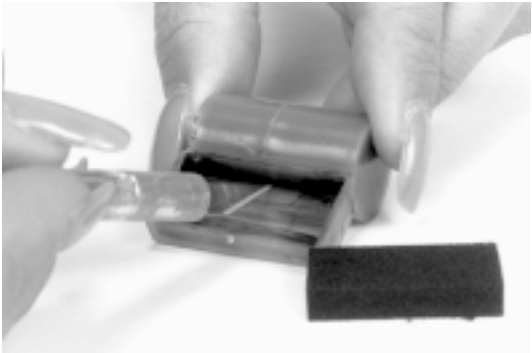

Photo B

We also suggest that when opening a new cartridge, use the piece of tape which holds the cover on to wrap around the cartridge about 1/4 of an inch (Photo C). This will help reduce excess ink on the numbering head especially when only using 3 or 4 digits where the foam would have a tendency to lift on the opposite side.

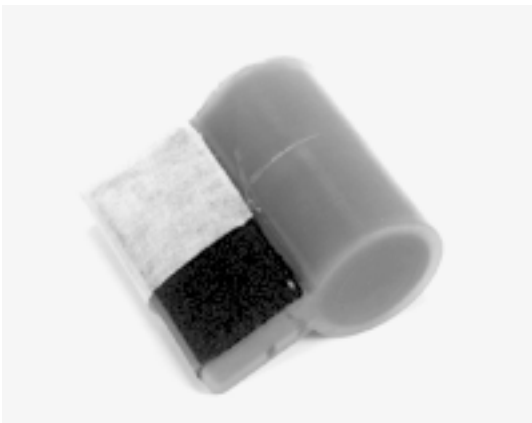

Photo C

TROUBLE SHOOTING

- **POWER DOES NOT TURN ON:**

1. Check circuit breakers on rear panel
2. Check outlet for power.

- **POWER TURNS ON (FAN ON) BUT MICROPROCESSOR DOES NOT LIGHT UP:**

1. Check 1/4 amp & 3 amp fuse on rear panel.
2. Check connector from control board to machine.

- **MICROPROCESSOR COMES ON BUT DISPLAY IS SCRAMBLED:**

1. Poor connection on or to control board.
2. Turn power off then turn back on. If display remains scrambled, contact count service Dept.

- **TRANSPORT "LOCKS UP" AFTER NUMBERING HEAD STAMPS:**

1. Check pulleys to make sure they are securely tightened on shafts.
2. Check to see that transport turns freely (oil when necessary).
3. Possible damage to microprocessor.

- **FEED TABLE NOT FEEDING CORRECTLY :**

1. Clean feed wheel rollers.
2. Rotate stationary roller (be sure roller does not turn freely) see pg. 14.
3. Bent retard spring (be sure spring is pressured against stationary roller) see pg. 14.

- **SHEETS NOT FEEDING STRAIGHT:**

1. Be sure paper guide bearings are not set in line with feed rails.
2. Align feed rails "check for squareness". This can be checked by the lead edge of the paper feeding into the machine should line up with the front edge of the feed plate.
3. Not enough pressure on forwarding rollers.
4. Clean ALL rubber rollers.

- **PERF IS NOT STRAIGHT:**

1. Check for equal pressure on all grip wheels and that none are hanging up.
2. Recheck all steps under (SHEETS NOT FEEDING STRAIGHT).

- **PERFORATION IS NOT CLEAN OR CUTS SHEET:**

1. Not enough pressure on perf wheel.
2. Perf blade is worn.

- **NUMBERS NOT REGISTERING ON SHEET:**

1. Clean all rubber rollers.
2. Check pressure on grip wheels. If these are not down firmly, your registration will be off.
3. Be sure paper guide bearings are not set in line with feed rails.
4. Check all pulleys to make sure are securely tightened on shafts.
5. Check to see that machine transport turns freely.

- **NUMBER APPEARS BLURRY:**

1. Head is not level. See "leveling a head pg. 23."
2. Not enough pressure, adjust with height adjustment screw.
3. Too much pressure, solenoid cannot make full stroke.
4. Head not tightened properly on head bracket.
5. Ink cartridge is empty or flow of ink is not consistent (**TRY ROTATING THE INK PAD**).

- **HEAD FIRES BUT NUMBER DOES NOT ADVANCE:**

1. Head set too low cannot make full stroke.
2. Head is dirty. Clean with Count Clean & Lube.
3. Possible damaged or broken action indicator.

- **NUMBERS TURN OUT OF SEQUENCE:**

1. Head is dirty. Clean with Count Clean & Lube.
2. Head is worn or damaged, contact Count service Dept.

SERVICE DIAGRAM A

AP-PLUS Side Frame Left

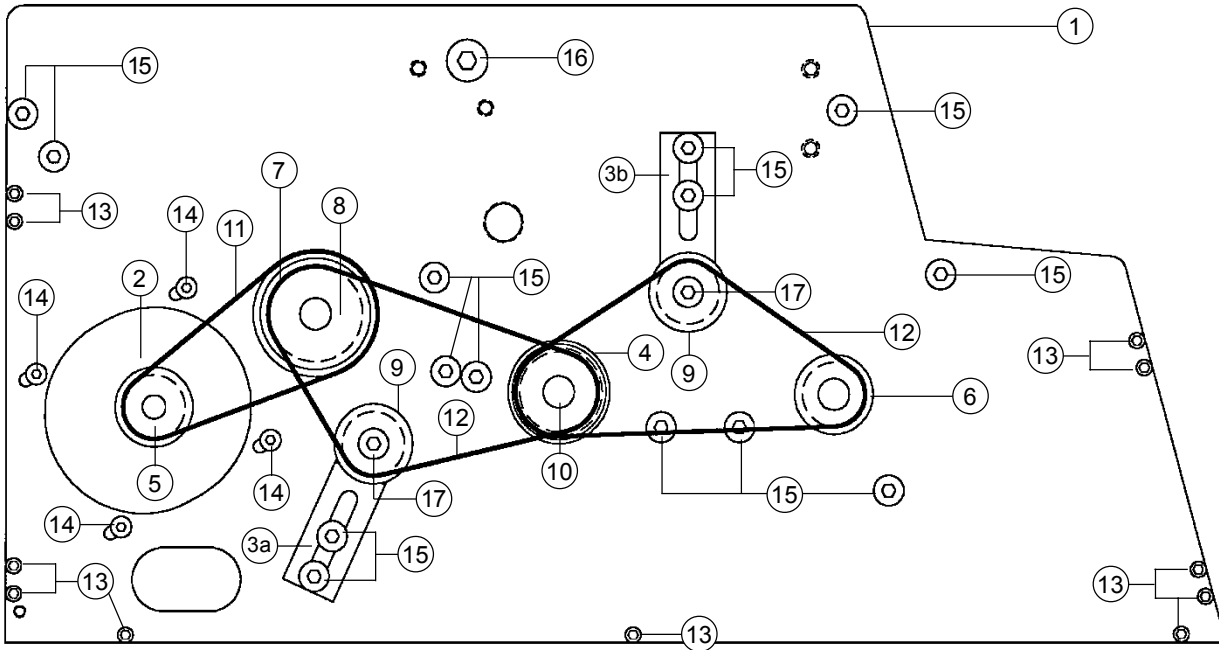

Description	Part #
1. AP Plus Left Side Frame Assy.	S-APP-0381
2. Stepping Motor	E-0800
3. a. Idler Pulley Assy.	S-APP-0646
b. Idler Pulley Assy.	S-APP-0645
4. Pulley, Timing - 1/5 pitch 22 toothed	H-0729
5. Pulley, Timing - 1/5 pitch 18 toothed	H-0724
6. Pulley, Timing - 1/5 pitch 18 toothed (1/2" bore).....	H-0706
7. Pulley, Timing - 1/5 pitch 32 toothed	H-0728
8. Pulley, Timing - 1/5 pitch 26 toothed	H-0734
9. Pulley, Timing - 1/5 pitch 16 toothed	H-0721
10. Pulley, Timing - 1/5 pitch 20 toothed	H-0704
11. Belt, Timing - 1/5 pitch 110xL037	H-0704
12. Belt, Timing - 1/5 pitch 140xL037	H-0700
13. 10-32x1/2" Socket cap bolt.....	H-0225
14. 10-32x1" Socket cap bolt.....	H-0245
15. 1/4-20x3/4 Socket cap bolt	H-0315
16. 5/16-18x1 1/4" Socket cap bolt.....	H-0365
17. Screw - 5/16"x3/4" shoulder	H-0380

SERVICE DIAGRAM B

AP-PLUS Side Frame Right

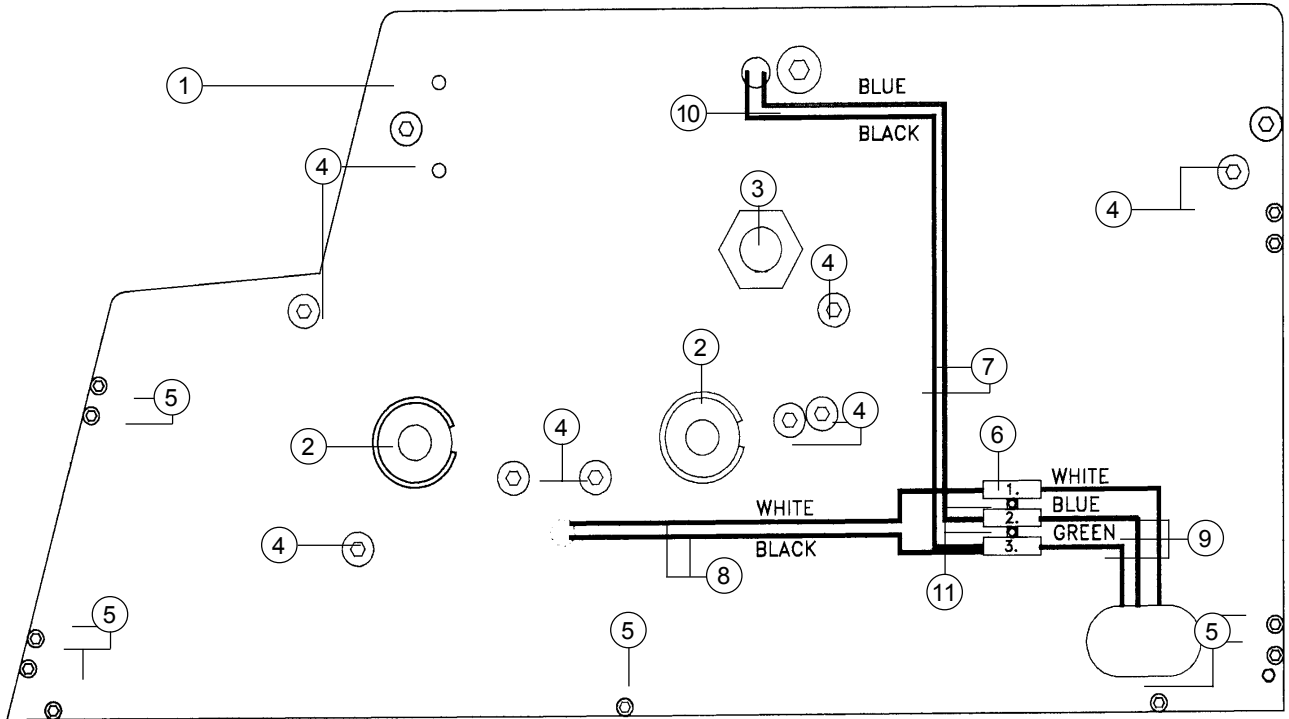

Description	Part #
1. AP Plus Right Side Frame Assy.	S-APP-0382
2. Roller bearings flanged 1/2" I.D.	H-0678
3. Hex nut - 5/8-18	H-0425
4. 1/4-20x3/4" Socket cap bolt	H-0315
5. 10-32x1/2" Socket cap bolt	H-0225
6. Wire Terminal Block	E-0860
7. Upper Sensor Wire Assy.	S-AAM-0760
8. Lower Sensor Wire Assy.	S-AAM-0230
9. Part of Main Wiring Harness Assy. - APP-18"	S-APP-0347
10. 5/16-18x1 1/4" Socket cap bolt	H-0365
11. 6-32x5/8" Phil pan head	H-0160

SERVICE DIAGRAM C

Inner Side Frame and Base

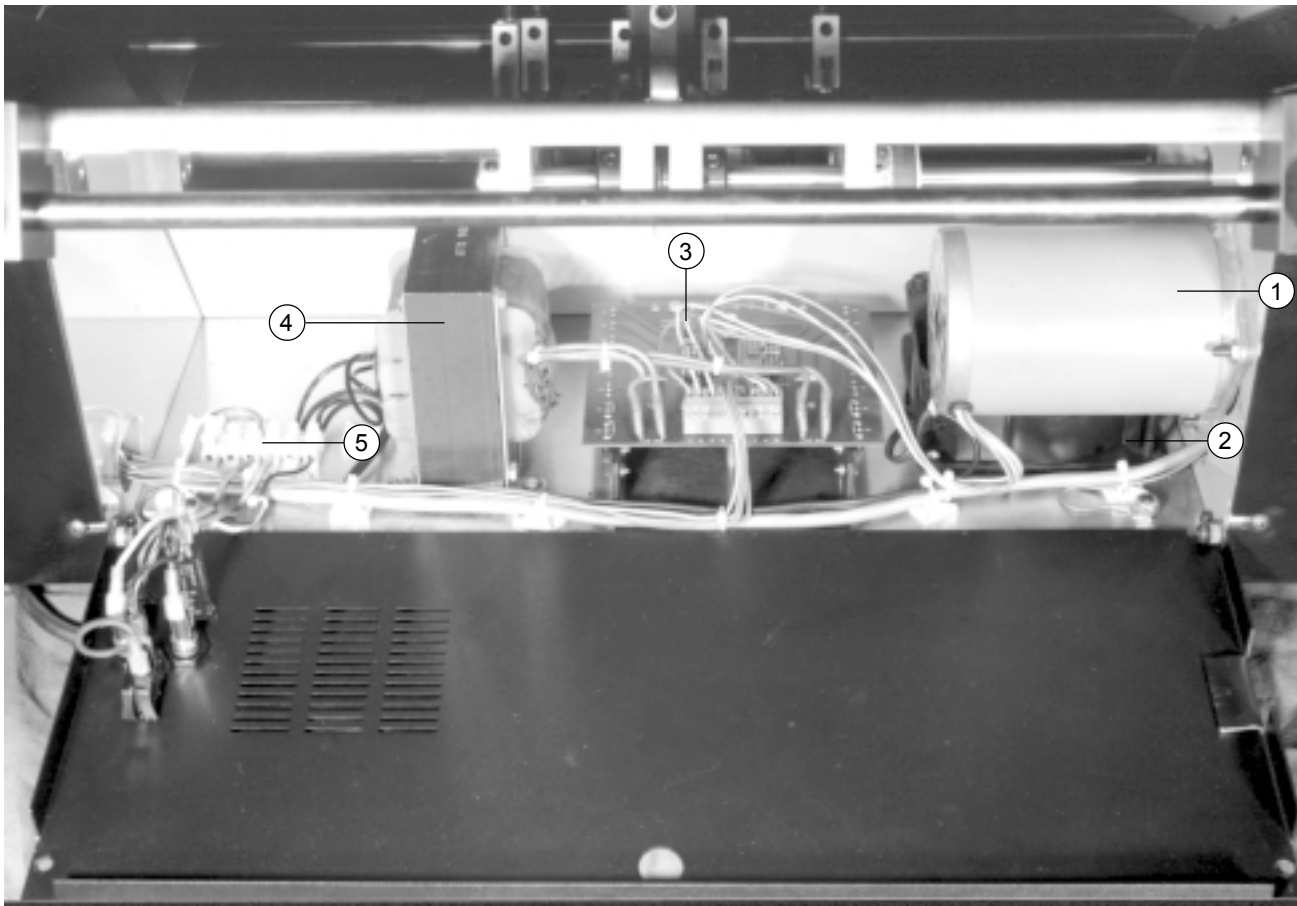

	Description	Part #
1.	Stepper Motor	E-0800
2.	Stepper Motor Fan	E-0855
3.	Motor Driver Board	S-AAM-0350
4.	Transformer	E-0665
5.	Base Terminal Block	E-0860

SERVICE DIAGRAM D

Feed Table / Entrance View

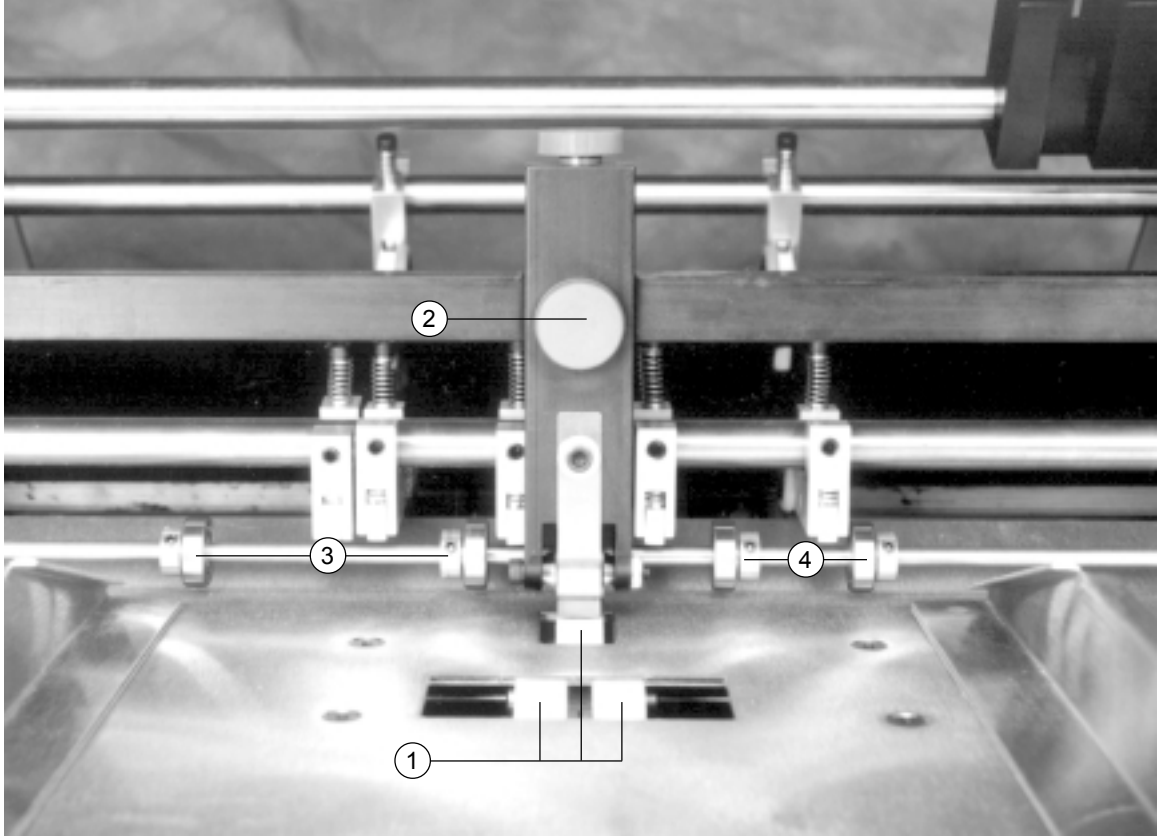

Description	Part #
1. Feed Wheel Roller (3)	E-0410
2. Paper Caliper Assembly 18"	S-AAM-0571
3. Paper Bend Guide Bearings	S-APP-0112



251 Wedcor Avenue, Wabash, Indiana 46992

Website: www.countmachinery.com Email: Info@martinyale.com

Fax: (260) 563-4575