



Digital Color Inkjet Printer

MACH 5

AS-950C



Powered by
memjet®



SAFETY PRECAUTIONS

THIS EQUIPMENT PRESENTS NO PROBLEM WHEN USED PROPERLY. HOWEVER, CERTAIN SAFETY RULES SHOULD BE OBSERVED WHEN OPERATING THE MACH 5 PRINTER.

BEFORE USING THE PRINTER, YOU SHOULD READ THIS MANUAL CAREFULLY AND FOLLOW THE RECOMMENDED PROCEDURES, SAFETY WARNINGS, AND INSTRUCTIONS:

- ✓ Keep hands, hair, and clothing clear of rollers and other moving parts.
- ✓ Avoid touching moving parts or materials while the machine is in use. Before clearing a jam, be sure machine mechanisms come to a stop.
- ✓ Always turn off the machine before making adjustments, cleaning the machine, or performing any maintenance covered in this manual.
- ✓ The power cord and power supply supplied with the machine should be plugged into a properly grounded, easily accessible wall outlet near the machine. Failure to properly ground the machine can result in severe personal injury and/or fire.
- ✓ The power cord and wall plug are the primary means of disconnecting the machine from the power supply.
- ✓ DO NOT use an adapter plug on the line cord or wall outlet.
- ✓ DO NOT remove the ground pin from the line cord.
- ✓ DO NOT route the power cord over sharp edges or trap it between furniture.
- ✓ Avoid using wall outlets that are controlled by wall switches or shared with other equipment.
- ✓ Make sure there is no strain on the power cord caused by jamming between equipment, walls, or furniture.
- ✓ DO NOT remove covers. Covers enclose hazardous parts that should only be accessed by a qualified service representative. Report any cover damage to your service representative.
- ✓ This machine requires periodic maintenance. Contact your authorized service representative for required service schedules.
- ✓ To prevent overheating, do not cover the vent openings.
- ✓ Use this equipment only for its intended purpose.
- ✓ In addition, follow any specific occupational safety and health standards for your workplace or area.

This manual is intended solely for the use and information of Quadient, its designated agents, customers, and their employees. The information in this guide was obtained from several different sources that are deemed reliable by all industry standards. To the best of our knowledge, that information is accurate in all respects. However, neither Quadient nor any of its agents or employees shall be responsible for any inaccuracies contained herein.

Memjet® is a registered trademark.

All other trademarks are the property of their respective holders.

All rights reserved. No part of this book may be reproduced or transmitted in any form or by any means, electronic or mechanical, including photocopying, recording, or any information storage and retrieval system, without permission in writing from the publisher

SAFETY PRECAUTIONS.....	1
SECTION 1 – GETTING ACQUAINTED	6
FRONT VIEW	6
REAR VIEW	7
PRINT ENGINE AREA	8
BEHIND THE INK TANK DOOR.....	9
CONTROL PANEL BUTTON/LED INDICATORS.....	10
SECTION 2 – INSTALLING THE PRINTER.....	11
TRANSPORT INSPECTION	11
TOOLS NEEDED	11
CHOOSING THE LOCATION	12
OPERATING CONDITIONS	12
UNPACKING.....	13
<i>Accessory Box Contents</i>	<i>14</i>
REMOVING THE CARDBOARD SHIPPING INSERT AND SHIPPING TAPE	15
INSTALLING MEDIA GUIDES & REAR MEDIA SUPPORT	16
CONNECTING THE PRINTER.....	18
<i>Plugging in the Printer.....</i>	<i>18</i>
<i>Powering the Printer ON and OFF</i>	<i>18</i>
<i>Connecting to the Computer.....</i>	<i>19</i>
<i>Minimum Computer System Requirements.....</i>	<i>19</i>
INSTALLING THE PRINTER SOFTWARE (DRIVER & TOOLBOX).....	20
<i>Connecting the Printer via Network (Ethernet Port).....</i>	<i>23</i>
INSTALLING THE INK TANKS.....	25
<i>Ink Tank Anatomy.....</i>	<i>25</i>
<i>Procedure (Installing the Ink Tanks):</i>	<i>26</i>
INSTALLING THE PRINthead CARTRIDGE	29
<i>Protective Packaging.....</i>	<i>29</i>
<i>Procedure (Installing the Printhead Cartridge).....</i>	<i>31</i>
ENVELOPE PRINTING ATTACHMENT KIT.....	35
<i>Installing/Removing the Head Media Guide.....</i>	<i>35</i>
<i>Installing/Removing the PPS Spacers</i>	<i>37</i>
SECTION 3 – OPERATING THE PRINTER	38
SETTING UP THE FEED.....	38
PRINTER DRIVER PROPERTIES.....	41
TOOLBOX FEATURES.....	47
<i>Drop-Down Menu Options.....</i>	<i>47</i>
<i>Ink Usage Menu.....</i>	<i>52</i>
<i>Service Menus.....</i>	<i>54</i>
<i>Diagnostics</i>	<i>55</i>
<i>Scan Sensors</i>	<i>58</i>
<i>Maintenance Menu</i>	<i>59</i>
<i>Service Menu</i>	<i>61</i>
<i>Print Menu.....</i>	<i>62</i>
PRINTING.....	63
<i>Printhead Cartridge Conditioning.....</i>	<i>63</i>
SECTION 4 – SOFTWARE SETUP INFORMATION.....	64
GENERAL SOFTWARE SETUP INFO	64

TABLE OF CONTENTS

ADOBE® ACROBAT/READER SETUP TIPS	65
SETTING UP A JOB IN BULK MAILER®	67
SECTION 5 - MAINTENANCE	74
REPLACING THE INK TANKS	74
<i>Cleaning Ink Tank Contacts & Prism</i>	77
<i>Ink Tank Storage</i>	79
<i>Ink Tank Service Life</i>	79
<i>Ink Tank Disposal</i>	79
CLEANING THE PRINthead CARTRIDGE	80
REPLACING THE PRINthead CARTRIDGE	83
<i>Printhead Storage</i>	84
<i>Printhead Service Life</i>	84
<i>Printhead Disposal</i>	85
INSPECTING & CLEANING THE LIP OF THE CAPPING STATION	85
INSPECTING THE WIPER ROLLER	86
CLEANING/REPLACING SERVICE STATION ITEMS	87
<i>Removing the Service Station</i>	87
<i>Cleaning the Service Station</i>	89
<i>Installing the Service Station</i>	92
<i>Still Experiencing Print Quality Issues?</i>	95
INSPECTING/REPLACING THE WASTE INK TRAY	96
REPLACING THE SHEET SEPARATORS	97
CLEARING MEDIA JAMS	98
CLEANING THE PRINTER BODY.....	99
CLEANING THE FEED ROLLERS AND FORWARDING ROLLERS.....	100
CLEANING THE FEED SENSOR	101
CLEANING OTHER ITEMS INSIDE THE PRINT ENGINE	102
<i>Grit Rollers (Media Transport Rollers)</i>	102
<i>Media (Paperpath) Sensors</i>	102
<i>Capping Station Lip</i>	102
<i>Paperpath Surfaces</i>	102
<i>Printing Platen Surface</i>	102
<i>Cleaning the Ink Revolver Couplings</i>	104
PRINTER MAINTENANCE SCHEDULE.....	105
PREPARING PRINTER FOR TRANSPORT.....	106
<i>Local relocation</i>	106
<i>Remote relocation or shipping</i>	106
SECTION 6 – TROUBLESHOOTING GUIDE.....	108
PRINT QUALITY ISSUES:	108
<i>Examples of Print Quality Issues (including possible causes and solutions)</i>	109
THE INK TANK(S)	115
THE PRINthead CARTRIDGE	116
THE PRINTER	118
<i>Dots or Lines Printed on Media</i>	118
<i>Power Problems</i>	118
<i>Service Station Problems</i>	119
<i>Interface Communication Problems</i>	120
<i>Feeding Problems</i>	121
ERRORS AND WARNINGS	122
<i>Printer Alert Window Messages</i>	122
<i>Toolbox System Status Messages</i>	123

TABLE OF CONTENTS

APPENDIX A – PRINTER SPECIFICATIONS..... 127

APPENDIX B – SUPPLIES AND OPTIONAL HARDWARE 128

 OBTAINING SUPPLIES, SERVICE AND SUPPORT 128

APPENDIX C – QUICK REFERENCE INFO 129

 CONTROL PANEL LIGHT SEQUENCES – QUICK REFERENCE..... 129

Section 1 – Getting Acquainted

Front View

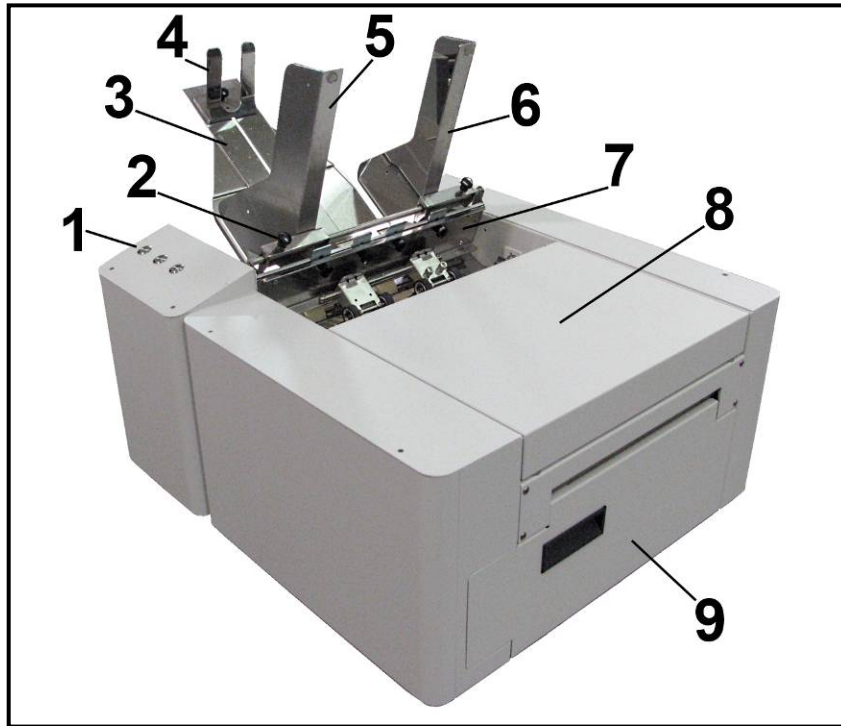

1.	Control Panel – Provides printer controls. See "Control Panel Functions" section
2.	Side Guide Locking Knob – Used to secure the position of the side guide.
3.	Rear Media Support Guide – Provides the proper angle to enhance paper feeding and separation.
4.	Media Support Wedge – Allows for adjustments in stack angle, based on media type and length. Helps to force the media against the separation area. Narrow and wide wedges are provided with the printer to accommodate different media widths.
5.	Adjustable Media Side Guide – Adjusts to hold the paper/media against the Media Registration Side Guide.
6.	Media Registration Side Guide – All media is registered against this guide. It has two positions. Inner position for media measuring 3" to 8.5" in width. Outer position for media measuring 8.6" to 9.5" in width.
7.	Sheet Separator Locking Screws – These thumb screws (four total) are used to secure the positions of the sheet separators.
8.	Top Cover – Provides access to the Print Engine.
9.	Ink Tank Door – Hinged door access to the Service Station, Ink Tanks and Waste Ink Tray. NOTE: On earlier units the cover above the Ink Tank Door had to be removed to access the Service Station.

Rear View

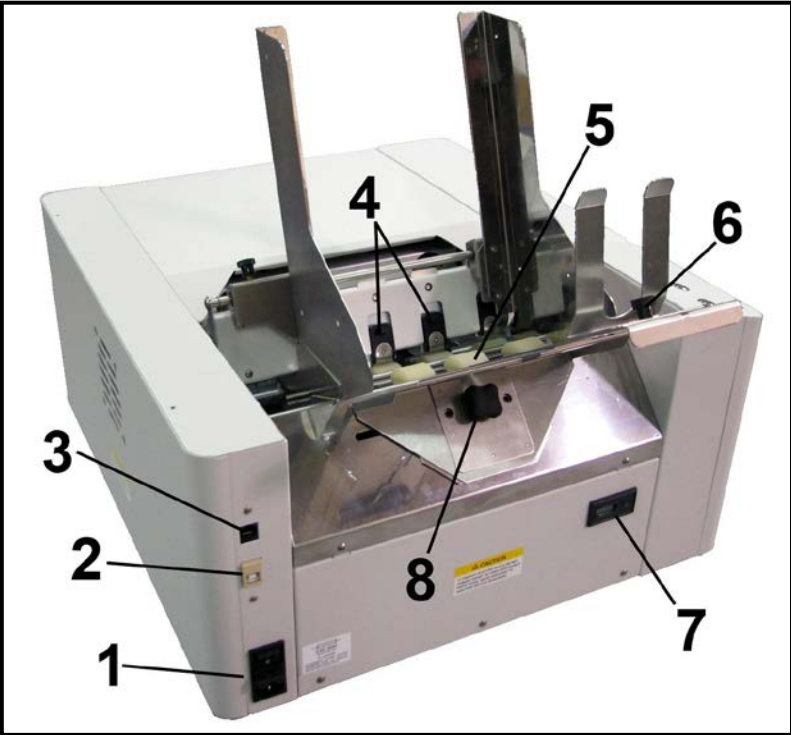

<p>1.</p>	<p>Main Power Switch, Receptacle and Fuse – Plug in AC power cord here. Switch turns main power ON/OFF. Fuse provides over-current protection. Fuse rating: 2.5A, 250V, slow blow. CAUTION: Make sure power cord is disconnected from printer before checking/replacing fuse.</p> <p>WARNING: Press the ON/OFF Button, located on the control panel, to properly shut-down the print engine. Wait until all control panel lights turn off, before you turn off the main power switch.</p> <p>For best system performance, it is recommended to always keep the print engine powered-up.</p>
<p>2.</p>	<p>USB Port Connection – (USB 2.0) The USB cable attaches to the printer here.</p>
<p>3.</p>	<p>Network Connection– (Ethernet) The network cable plugs in here.</p>
<p>4.</p>	<p>Sheet Separators – Used to separate a single piece of media from the stack. There are four sheet separators on this printer.</p>
<p>5.</p>	<p>Feed Rollers – Used to deliver the bottom piece of media from the stack, through the sheet separation area, and present it to the first set of transport rollers.</p>
<p>6.</p>	<p>Media Support Wedge Thumb Screw –Used to secure the Media Support Wedge to the Rear Media Support Guide.</p>
<p>7.</p>	<p>Counter – Non-resettable. LCD displays the total number of pieces fed through the Printer. NOTE: The number of pieces fed will normally be higher than the number of pieces printed.</p>
<p>8.</p>	<p>Rear Media Support Guide Knob – Attaches the Rear Media Support Guide to the body of the printer.</p>

Print Engine Area

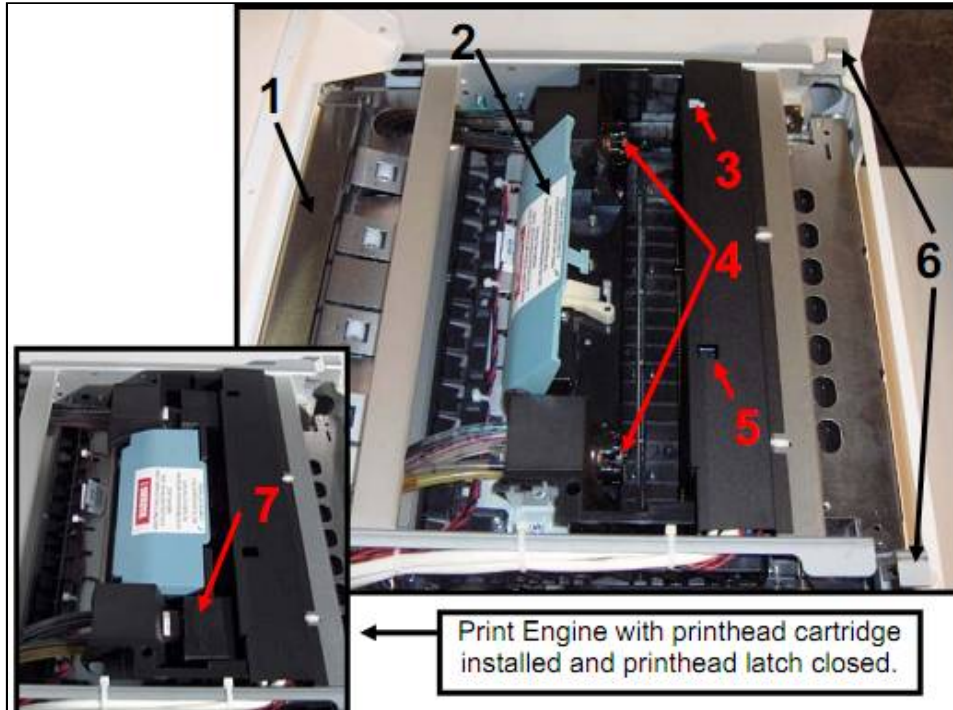

1.	Antistatic Brush Assembly – Contains an antistatic brush that is used to help reduce static energy and remove paper dust from the media. This assembly also contains pressure rollers and fingers that help guide the paper into the print engine.
2.	Printhead Latch – When closed, connects the Ink Revolver Couplings with the Printhead Cartridge. When opened, retracts the Ink Couplings from the Printhead Cartridge, and provides access for Printhead Cartridge install/removal/replacement. WARNING! Never attempt to open the Printhead Latch manually, severe damage will result. Use the “Release Printhead” button, in the Toolbox utility on your PC, or press the Printhead Latch Release Button (<i>See #5 above</i>).
3.	Print Ink Channels Button* – Prints 5 bars (<i>1 bar from each ink tank</i>) to indicate how well the Printhead Nozzles are working. Lightly press the button with a non-conductive tool. *Same function can be accessed through the Printer Toolbox Diagnostics screen on your computer.
4.	Ink Revolver Couplings – Connect the ink hoses to the Printhead Cartridge. The Printhead Latch extends and retracts the couplings from the Printhead.
5.	Printhead Latch Release Button* – Button inside opening will initiate a Printhead Latch release cycle. If system is primed, runs a full system deprime cycle before the Latch is released. Lightly press the button with a non-conductive tool. *Same function can be accessed through the Printer Toolbox User Interface screen on your computer.
6.	Clamshell Latches – Use two hands to release both latches, while gently opening or closing the Print Engine Clamshell. Do NOT force the Clamshell open or closed. Do NOT open the Clamshell while the Printer is operating or making noise.
7.	Printhead Cartridge – Memjet® Printhead produces an 8.5" wide full color print area.

Behind the Ink Tank Door

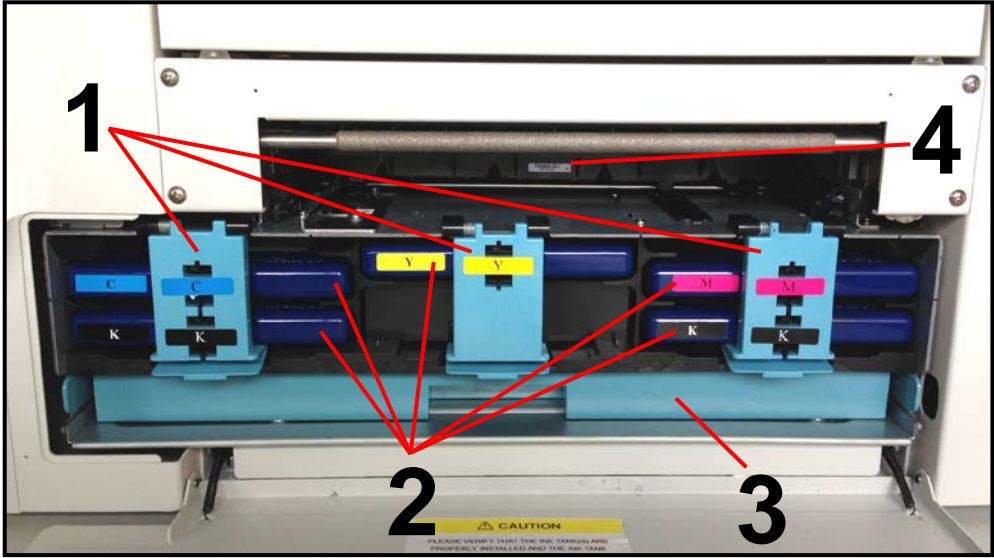

<p>1.</p>	<p>Ink Tank Securing Latches – Used to hold the Ink Tanks securely into the slots and against the electrical contacts within the print engine. NOTE: Please be sure that both sides, at the bottom part of the latch, are engaged.</p> <p>CAUTION! Before removing/installing Ink Tanks, please be sure to power-down the Print Engine or press the “Replace Ink Tanks” button, in the Toolbox. If this rule is not followed damage to the Ink Tanks may result, rendering them unusable.</p>
<p>2.</p>	<p>Ink Tanks – Five Ink Tanks are used in the printer. Cyan (C), Yellow (Y), Magenta (M), Black (K), Black (K)</p>
<p>3.</p>	<p>Waste Ink Tray – The purpose of this tray is to catch the waste ink produced by the system. This tray is filled with absorbent material. This tray must be replaced when it becomes saturated. Please inspect routinely. The tabs located at the left and right sides of the tray secure the tray to the print engine frame. Please be sure the tabs “click” into the frame, to secure the tray's position.</p>
<p>4.</p>	<p>Service Station – Contains four major components.</p> <ul style="list-style-type: none"> - Wiper Roller Assembly - cleans the Printhead Cartridge of excess ink and debris. - Capping Station - keeps the Printhead capped, hydrated, and protected when not in use. - Printing Platen - provides the base to support media during feeding and printing. - Tray – holds all the above components and captures the waste ink. The waste ink eventual makes its way from the Service Station Tray into the Waste Ink Tray. <p>Please refer to the “Operator Maintenance” section for information on how to properly maintain the Service Station and its components.</p>

**SECTION 1
GETTING ACQUAINTED**

Control Panel Button/LED Indicators

The Control Panel has 3 buttons with LED indicators.

POWER (ON/OFF) – Turns Printer power ON and OFF. Turn off power for cleaning and maintenance

PAPER/RESUME – Press to Resume printing after a paper feed error (*such as a paper jam or running out of paper*) and/or after a job is paused with the **Pause** button.



PAUSE/CANCEL – Pauses or Cancels a Job.

- **Press to Pause a Job.** Printer will clear media in machine and stop.
- **Press Again to Cancel a Job.** Once the Printer has stopped, pressing this button clears job from printer and print queue in driver.

NOTE: Cancelled Jobs must be reloaded before printing can resume.

LED Sequence	Printer Status	Recommended Action
Flashing, simultaneously 	Powering up or Shutting down	Wait for process to finish
ON, Steady 	Printer powered up in Standby mode	Load Media
ON, Steady 	One of the printing sensors is covered or dirty	Open Clamshell, remove media or clean sensors
Flashing SLOW 	Printer Paused, (Data pending)	Press PAPER/RESUME to Start/Resume printing or PAUSE/CANCEL to clear job
Flashing FAST 	Out Of Paper (Data pending, Media not present)	Reload Media, press PAPER/RESUME to Start/Resume printing, or PAUSE/CANCEL to clear job
ON, Steady 	Ink Supply error: Ink Out, Ink Missing, Printhead Unprimed...	Replace empty Ink Tank and press PAPER/RESUME to resume, or Circulate ink
Flashing SLOW, simultaneously 	Busy Signal: Performing maintenance, Loading, Ejecting media	Wait for process to finish
Flashing FAST, simultaneously 	Hardware error: Door Open, Machine tilted, Service Station Error, Printhead missing...	Find and fix error
Flashing, alternating 	Downloading Data, Printing	Press PAUSE/CANCEL to Pause printing

**See “Section 6” for additional Troubleshooting Information.
See “Appendix C” for a larger chart, to hang near the printer.**

Section 2 – Installing the Printer

Before using the MACH 5 printer the following must be done:

- Transport Inspection. Upon delivery, inspect packaging and report any issues to the Carrier
- Gather Tools
- Choose a location for the Printer
- Unpack and verify Accessory Box contents
- Attach the Media Guides to the Printer
- Remove the Service Station Transport Tab and Shipping Tape
- Plug in the Printer
- Install the Printer Software (Driver & Toolbox). Then Connect Printer to Computer
- Install the Ink Tanks
- Install the Printhead
- Install the PPS spacers (if needed)

Transport Inspection

The printer is shipped in appropriate packaging so that, under normal shipping conditions, it reaches its destination without damage.

NOTICE: Report damage to the carrier. The carrier is liable for any damage during transport.

Transport and storage should take place under the following conditions:

- At temperatures between -25°C and +50°C (-13 °F to 122 °F).
- At a relative air humidity between 5% and 95%, non-condensing.
- At an atmospheric pressure between 70 kPa and 105 kPa.

Exposure to conditions that are not permissible may lead to damage which is not externally visible.

IMPORTANT Please save the packaging materials for future use! It will be required if you ever need to ship the printer. Before shipping, please refer to the section titled “Preparing the Printer for Transport”.

Tools Needed

- Knife and scissors to open packaging
- #2 Philips head screwdriver
- Carpenters Level (recommend using 18” or longer level)
- Protective, nitrile powder-free gloves should be worn to avoid getting ink on hands when removing protective packaging materials from the ink coupling areas, the Ink Tank areas, and when installing/removing Printhead Cartridge and Ink Tanks.
- Distilled or de-ionized water
- Non-abrasive, lint free cloths

SECTION 2 INSTALLING THE PRINTER

Choosing the Location

The printer should be placed on a sturdy, level, worktable, or cabinet, at least 9 inches from any walls. Protect the printer from excessive heat, dust, and moisture – avoid placing it in direct sunlight.

Place Printer on a sturdy level worktable or cabinet at least 9" from any walls.

Use the following methods to verify that the Table and Printer are level:

- A carpenter's level should be used to make sure Table is level (front to back and left to right).
- The *Bubble Gauge*, if equipped (located on top of the Clamshell), can be used to verify that the Printer is level. Open the Top Cover to access this area.

Why is placing the printer on a sturdy level worktable Important?

The printer's ink monitoring system, ink delivery systems, and waste ink drainage system, depend on the printer being level to perform properly. If this rule is not followed you may experience early ink out issues, print quality issues and ink waste draining issues that could cause damage to the printer and or other property.

- Do NOT use the Toolbox utilities "Tilt" readings to level the printer or table.
- Use an accurate level (i.e., bubble level that is at least 18" long), to check that the table surface is level (front to back and left to right).
It is not acceptable to use your "cell phone app" to check level.
- Do NOT shim, raise or otherwise modify the printer, or feet of the printer, in any way.
- If the table surface cannot be leveled, then the printer should not be placed on it.
- If the table is not sturdy, then the printer should not be placed on it.
- Do NOT move the printer while the power is on.

Operating Conditions

Operation should take place under the following conditions:

- At temperatures between +15°C and +30°C (59 °F to 86 °F).
With max temperature change of +/- 0.5°C (+/- 0.9°F) per minute.
- At a relative air humidity between 20% and 80%, non-condensing.
- At an atmospheric pressure between 70 kPa and 105 kPa.
- Printer and Print Engine should be protected from excessive environmental debris/dust.
- Printer must be placed on a "Sturdy/Level" surface.

Exposure to conditions that are not permissible may lead to damage which is not externally visible. Allow the printer, printhead and ink tanks to acclimate to ambient temperature before using the printer.

Unpacking

Please refer to the unpacking sequence, shown below.

NOTE: Packaging materials may vary slightly from what is shown below.

Please save the packaging in a safe place, for possible future use.

Two people will be required to safely lift the printer and place it onto a sturdy, level worktable.

IMPORTANT: WORKTABLE SURFACE MUST BE LEVEL! Level the Table, NOT the Printer!

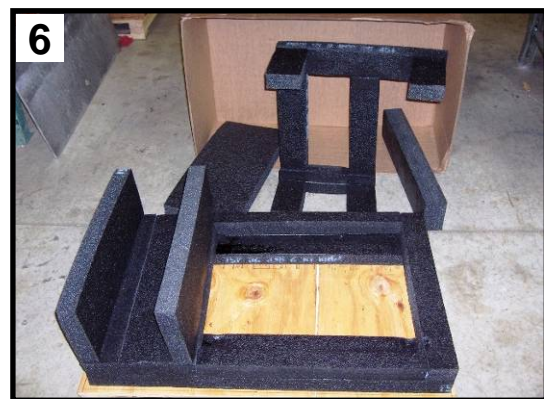

Save the Packaging for possible future use.

SECTION 2 INSTALLING THE PRINTER

Accessory Box Contents



Accessories Box



Ink Tank Packaging

The following items are included with your printer:

- [A] **Ink Tanks** (packed in foam molds)
 - Cyan, Magenta, Yellow, Black, Black
 - [B] **Printhead Cartridge** and packaging
 - [C] **Rear Media Support Guide**
 - thumb screw attached to printer
 - [D] **Service Station** (now pre-installed in printer)
 - [E] **Wide Media Support Wedge**
 - mounting hardware attached to item C
 - [F] **Narrow Media Support Wedge**
 - mounting hardware attached to item C
 - [G] **Media Registration Side Guide**
 - mounting screws attached to printer
 - [H] **Adjustable Media Side Guide**
 - mounting screws attached to printer
 - [I] **USB Cable**
 - [J] **Power Cord**
 - [K] **Operation CD** (replaced by USB Flash Drive)
 - contains printer software (driver) and operations manual (in pdf format)
- Ethernet Cable**, CAT5 (not shown)

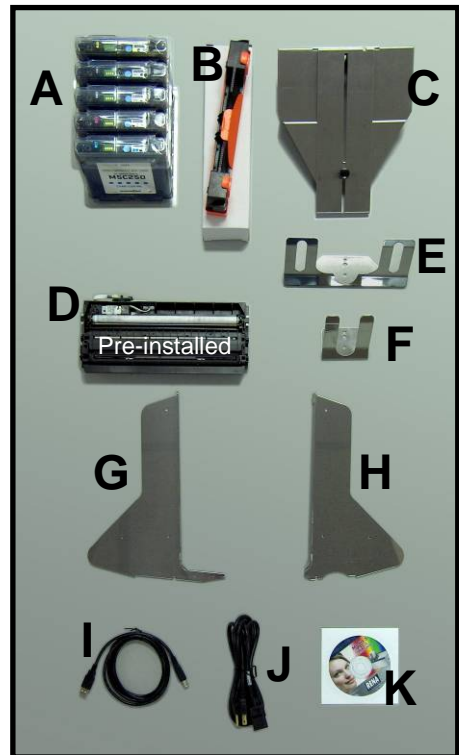

Note: Ink Tanks and Printhead Cartridges can be purchased through your local Dealer/Distributor. To locate an authorized Dealer/Distributor please visit our website. See “Appendix B” for supplies information.

Removing the cardboard Shipping Insert and Shipping Tape

WARNING! To avoid possible damage to the printer, do NOT plug-in, or power-up, the printer until all shipping materials have been removed as described below.

1. Open the Top Cover.
2. Carefully release both latches (*one on either side of the Print Engine*), and lift up with both hands, to gently swing open the Print Engine Clamshell.



CAUTION

**HOLD ONTO BOTH LATCHES WHEN OPENING AND CLOSING THE PRINT ENGINE CLAMSHELL TO PREVENT DAMAGE.
DO NOT FORCE THE ASSEMBLY CLOSED.**

3. Remove the cardboard “Shipping Insert” [A], by pulling up on both red tabs at the same time. The “Shipping Insert” secures the Service Station during printer transport.
4. Remove the Tape [B]. The tape wraps around the underside of the Clamshell to secure the Head Media Guide. (If necessary, wipe off any tape residue from the Head Media Guide surface [C].)
5. Gently close and latch the Clamshell.
6. Close the Top Cover.

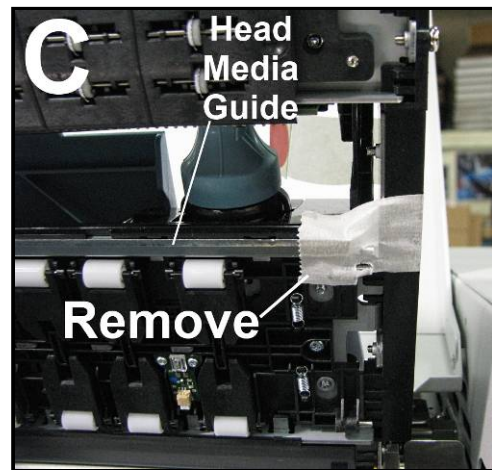
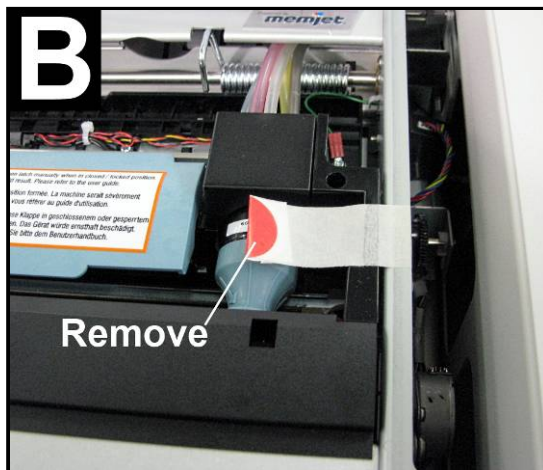
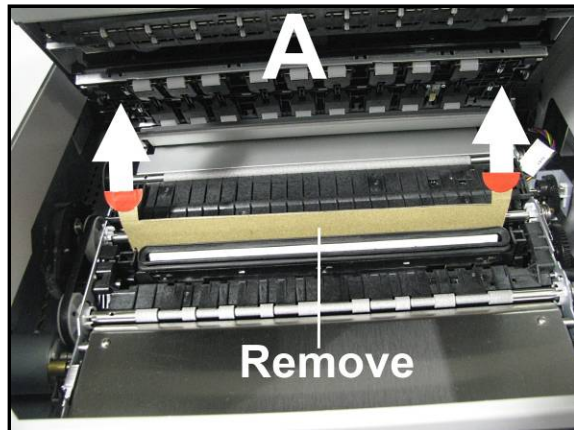

SECTION 2
INSTALLING THE PRINTER

Installing Media Guides & Rear Media Support

The screws needed to attach the side guides to the printer are located under the shipping tape in their respective positions.

1. Begin by installing the Media Registration Side Guide using the two screws [1] provided:

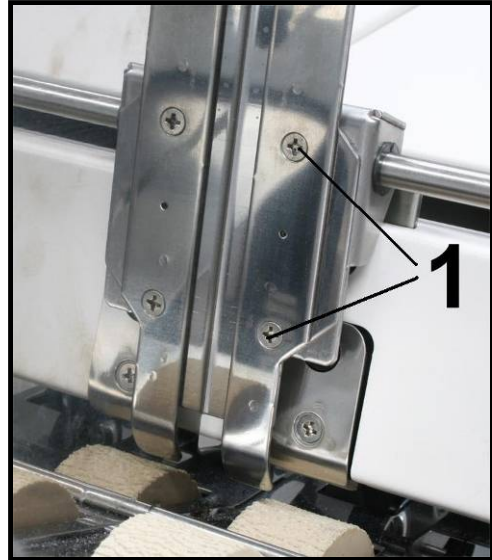

2. Next install the Adjustable Media Side Guide using the two screws [2] provided.

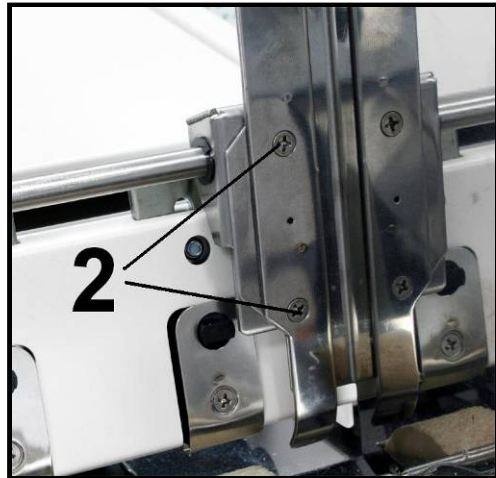

3. Attach the Rear Media Support Guide using the Knob [3] and washer provided.

Remove the knob and washer from the printer. Position the Rear Media Support Guide against the frame of the printer. The two outer holes in the guide fit over the socket head screws, as shown. Install the washer, then install and tighten the Knob.

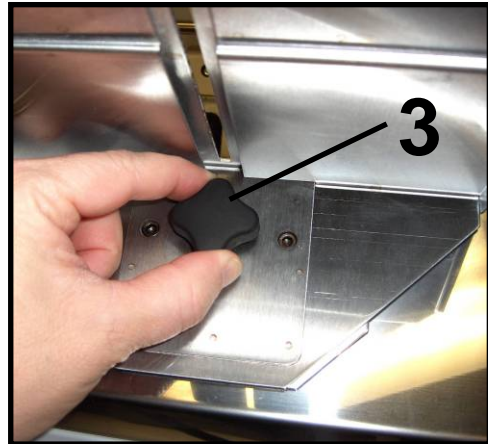

4. Install the desired Media Support Wedge using the mounting hardware [4], as described below.



Choose the appropriate Media Support Wedge for your application:

Wide Media Support Wedge [5]

- For media that is 8 to 9.5 inches wide.

Narrow Media Support Wedge [6]

- For media that is 3 to 8 inches wide.

The Anchor Plate [7] fits into the slot, from the underside of the Rear Media Support Guide. Position the Media Support Wedge so the upper and lower holes fit onto the two tabs from the Anchor Plate.

The washer [8] goes between the Thumb Screw [9] and the Media Support Wedge. The Thumb Screw is inserted down through the washer, then through the center hole in the Media Support Wedge and into the threaded hole in the Anchor Plate. Tighten the thumb screw to secure the Media Support Wedge onto the Rear Media Support Guide.

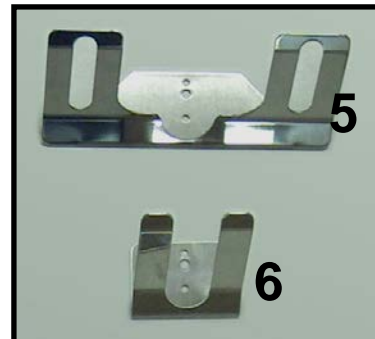

Connecting the Printer

Plugging in the Printer

- Check to make sure the Main Power Switch [1] is in the **OFF** position.
- Plug the Power Cord into the receptacle [1] at the rear of the Printer.
- Connect the other end of the Power Cord to a compatible AC Outlet that supplies 100-240 volts AC, 50/60 Hz and provides earth ground.
- The use of a power protection device is highly recommended, to reduce damage caused by voltage sags, surges and brown-outs.

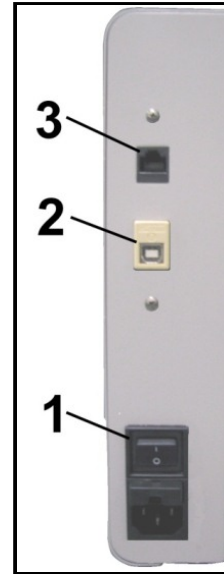

CAUTION

DO NOT USE AN ADAPTER PLUG OR EXTENSION CORD TO CONNECT THE PRINTER TO THE WALL RECEPTACLE.

DO NOT USE OUTLETS CONTROLLED BY WALL SWITCHES.

DO NOT USE AN OUTLET THAT SHARES THE SAME CIRCUIT WITH LARGE ELECTRICAL MACHINES OR APPLIANCES.

Powering the Printer ON and OFF

Powering-Up the Printer:

1. **Turn ON the Main Power Switch [1].**
2. **Press the Control Panel's ON/OFF Button.**
Wait about 45 seconds for the print engine to power-up (ON/OFF button will illuminate).

Powering-Down the Printer:

1. **Press the Control Panel's ON/OFF Button.**
Wait for the print engine to power-down (all Control Panel Buttons will turn OFF).
2. **Turn OFF the Main Power Switch [1].**

CAUTION

BEFORE POWERING OFF THE MAIN POWER SWITCH, ALWAYS POWER DOWN THE PRINT ENGINE, USING THE ON/OFF BUTTON.

IF THIS RULE IS NOT FOLLOWED DAMAGE TO THE PRINthead AND OR INK SYSTEM CAN RESULT.

FOR BEST SYSTEM PERFORMANCE, IT IS RECOMMENDED TO KEEP THE PRINT ENGINE POWERED-UP (ON/OFF LIGHT ILLUMINATED) AT ALL TIMES.

Connecting to the Computer

The Printer connects to the computer through the USB port [2]. A Network port [3] is also provided for connecting the printer to a network environment.

IMPORTANT: DO NOT connect the printer to the computer, until prompted to do so, during the printer driver installation process. See “Installing the Printer Software” section.

Minimum Computer System Requirements

- **Operating System:** Windows 7, Windows 8/8.1, Windows 10*.
Supports 32-bit and 64-bit systems
*M Series Driver version R15 or higher
- **You must have administrative privileges** on the computer system.
- **Microprocessor:** Pentium II, 2 GHz minimum (*Pentium Dual Core, 2.5 GHz or better, is optimal*)
- **System memory:** 2 GB minimum, or as recommended for your operating system.
- **Free hard-disk space:** At least 10 GB.
- **Web Browser:** Firefox recommended. Internet Explorer and Chrome also supported.
- **USB port (2.0/3.0):** (*Ports will be identified as “USB” or “Enhanced” in Device Manager*)
- **Microsoft .Net Framework** version 3.5 (*for 32-bit systems*) or Microsoft .Net Framework version 4 or higher (*for 64-bit systems*) must be installed.
NOTE for 32-bit System Users: Even if you have a higher .NET Framework version installed, version 3.5 must also be installed, or the Toolbox will not open.

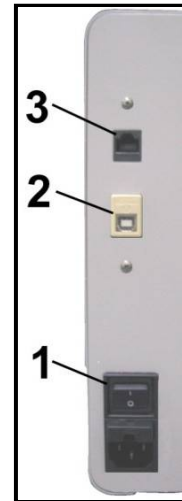

Known limitations when used on Windows 8/8.1/10

- The Toolbox is not compatible with the Microsoft Edge browser. Please use Internet Explorer, Firefox, or Chrome instead.
- Use in “Desktop Mode” only.
- Printing is not supported for “native” Windows 8/8.1/10 applications (apps that were developed strictly for Windows 8/8.1/10).
- Windows 10 users, to uninstall the driver: If the uninstall feature does not appear under All Apps, Memjet. go to “Settings”, “System”, “Apps & features”. Then locate and uninstall the “M Series Driver”.

How to check your system for the minimum system requirements, shown above:

Right click on "My Computer" and select Properties. The system information, including Operating System, Processor Info and Memory info will be displayed under the "General" tab.

How to check your system for the versions of "Microsoft .NET Framework" installed.

From the Control Panel, open "Add or Remove Programs" and look for "Microsoft .NET Framework 3.5..." or "Microsoft .NET Framework 4..." in the list.

You may be able to obtain "Microsoft .Net Framework 3.5 or 4" via the Microsoft website.

<http://www.microsoft.com>

SECTION 2 INSTALLING THE PRINTER

Installing the Printer Software (Driver & Toolbox)

For the Printer software to operate properly check that the computer system meets the minimum requirements. See section titled “Minimum Computer System Requirements”, on previous page.

NOTE: If you are updating the MACH 5 printer (M Series) printer software (printer driver and toolbox utility), please be sure to Uninstall the old software before installing the new software. Use the “Uninstall” feature found on your computer system under All Programs, “Memjet”, “M Series Driver”.

IMPORTANT: Before installing the Printer software (*Toolbox and Driver*), you should **temporarily disable all antivirus programs and firewalls**. In addition, you must be logged onto the system with full administrative privileges (*admin rights*).

NOTE: Even if you plan to use the printer via an Ethernet Network Connection, your initial connection to the printer must be done via USB, to access the Network Configuration Settings in the Toolbox.

Do NOT plug in the USB cable until prompted to do so.

PROCEDURE

1. Disconnect the USB cable connection from the printer if you plugged it in already.
2. Power-up the Printer. Turn ON the Main Power Switch, then press the Control Panel’s ON/OFF button. Wait about 45 seconds for the print engine to power-up (ON/OFF button will illuminate).
3. Connect **USB Flash Drive**, supplied with the printer, to USB port on your computer.
4. Browse the **USB Flash Drive**.
Locate and open the “**MACH 5**” folder.
Locate and open the “**M Series Driver**” folder.
Located and run “**WinSetup.exe**” to launch the “S Series Driver” installation utility.
Tip: For best results, Right-click and “run as administrator”.

NOTE: You may want to check the distributor’s website for a more recent version of the “S Series Driver” for the MACH 5.

5. When the “S Series Driver” installation utility opens, Click “**Install Printer Software**”.

NOTE: If you receive a Windows security or authorization warning, click on “YES” or “Continue Anyway”.

6. **Install Printer Software.** Make sure the computer system meets the **minimum requirements** and you have followed the other instructions listed on the screen. Click “**Install Printer Software**”.

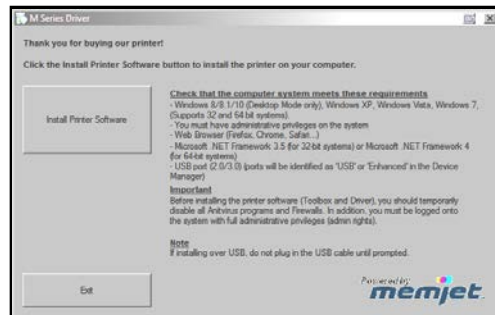

7. **License Agreement.** Check “I accept...” then click “Next>”.

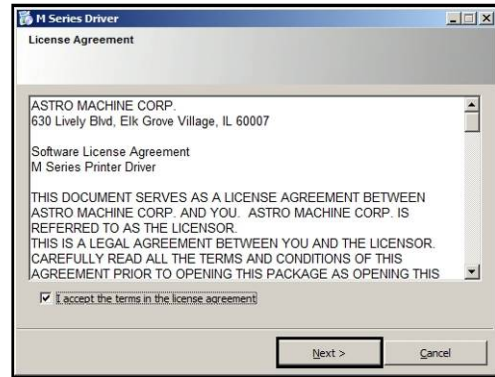

8. **Printer Connections.** Click “Configure to print using USB”. Then click “Next>”.

NOTE: Even if you plan to use the printer via an Ethernet Network Connection, your initial connection to the printer must be done via USB, to access the Network Configuration Settings in the Toolbox.

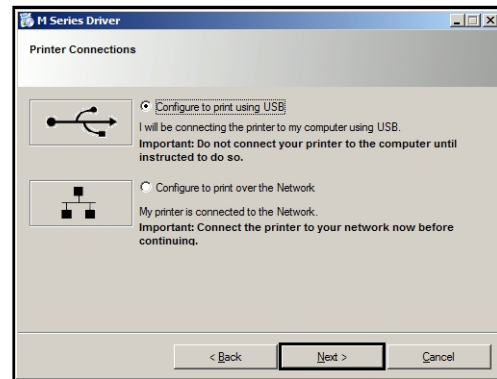

9. After a few moments the **Installing Printer Software** window opens and begins preinstalling the software.

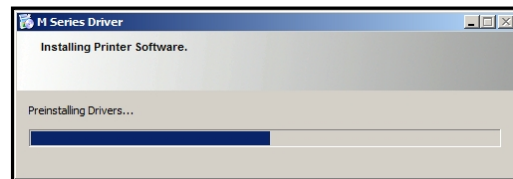

10. As the software load, the “Would You Like to Install This Device Software?” window appears. Click “Install”.

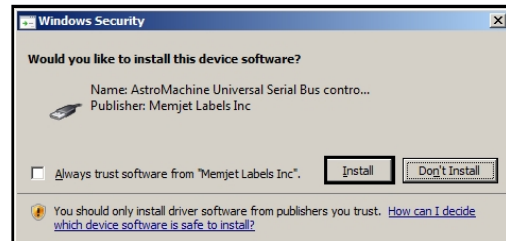

11. The “Connect Device Now” window opens. Connect the USB cable, from the computer to the printer, at this time.

Don't click on either button (Back or Cancel). The software will automatically continue once it recognizes the printer (printer powered on and USB cable connected).

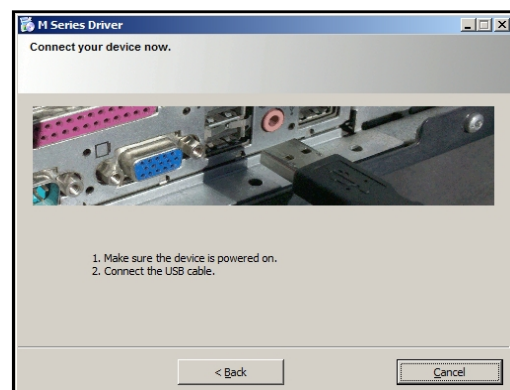

SECTION 2 INSTALLING THE PRINTER

12. The “**Finished software installation**” window opens. Do not select (check) the **Print Test Page** as the Printer is not set up yet. If desired, you can select (check) the “Set this printer as the default printer” at this time. Then click **Next>**.

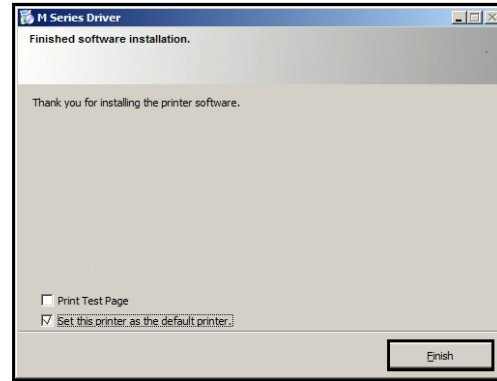

13. Click on “**Exit**” to close the “**Install Printer Software**” window.
14. Restart the computer to complete the installation.

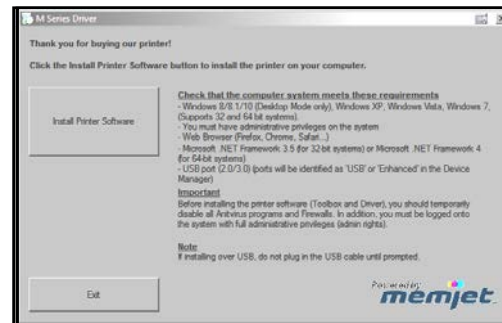

The “M Series Driver” should now be available in your “Printer and Faxes” or “Devices and Printers” folder.

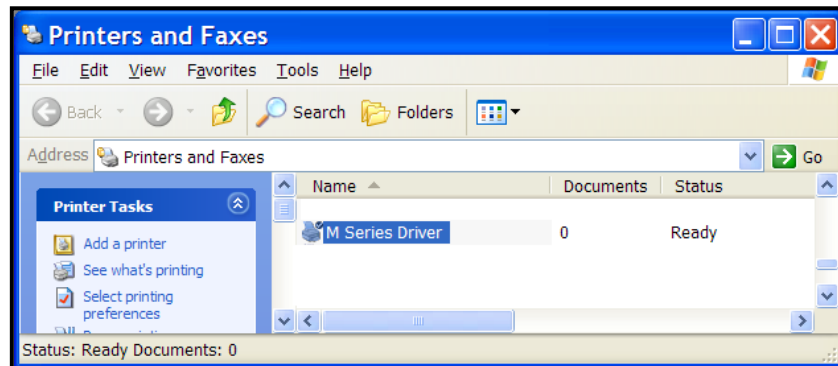

Tip: After you have completed printer setup (ink tanks installed, printhead cartridge installed, media feed setup), it is a good idea to print a test page from the printer driver to confirm that the printer driver and printer are communicating. This is done by right-clicking on the “M Series Driver” and selecting “Properties” (Printer properties in Win7). Then click on the “Print Test Page” button.

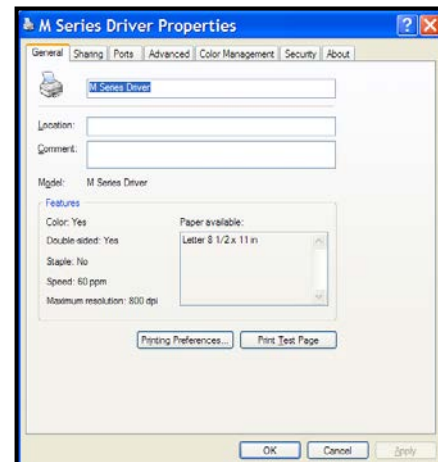

Connecting the Printer via Network (Ethernet Port)

1. If you haven't already done so, install the Printer Software (M Series Driver and Toolbox), via USB, by following the instructions in the previous section.
Note: Initially the USB connection is needed to configure the printer's internal network settings. Once the software installation is complete, you can proceed to the next step.

2. Open the M Series "Toolbox" utility.

To open the Toolbox utility, click on Start, All Programs, Memjet, M Series Driver, Toolbox. The Toolbox will open in a Web Browser (Example: Internet Explorer) window.

Tip: If you receive warning that Windows Firewall has blocked some features of this program. Please select Private Networks and then click on **Allow Access**.

3. Open the "View" drop-down menu. Select "Service Menus". Select "System Settings" button.

4. When the "System Settings" window appears, configure the printer's network settings as needed under "Network Settings".

See example.

Check with your IT support person for help with these settings.

Be sure to click on "Submit" after entering new information.

NOTE: The information shown on this page is just an example. You must use settings that are compatible with your network and settings that are not in direct conflict with other devices on the network.

We strongly suggest using a "Static" IP address.

The screenshot shows the printer's web interface with the following details:

- System Settings** (highlighted with a red box)
- Network Settings**
 - Printer Name: MyPrinter1
 - Domain Name: ABCName.com
 - dhcp: (highlighted with a red box)
 - bootp: (highlighted with a red box)
 - autoip: (highlighted with a red box)
 - ip_address: 192.168.254.119 (highlighted with a red box)
 - subnet_mask: 255.255.255.0
 - def_gateway: 192.168.254.254
 - wins_server: 192.168.254.11
- Date and Time**
 - Date and Time: 14/11/17 07:31
 - 24 Hour:
 - Date Format: mm/dd/yy

AutoIP Network Tip:

For network systems that automatically assign or obtain the IP Address, make sure the appropriate items (dhcp, bootp, autoip), for your network, are checked (selected).

Static IP Network Tip:

Running "ipconfig", from the Command Prompt of a computer that is being used on the same network, may help you define some of the information needed for this setup. In general, you can use the same "Subnet Mask" and "Default Gateway" that are shown in the "Windows IP Configuration". However, you need to provide a unique "IP Address" for the printer. For example, if the "Windows IP Configuration", IP Address for your computer's connection is shown as 10.30.100.169 you may be able to use 10.30.100.170 for the printer, if this IP Address is not in use by some other device.

If you want to check for an open IP Address you can ping the address before you save the settings and connect the printer. Type "ping [ip address]" (Example: ping 10.30.100.170) at the command prompt. An open IP Address will show "Request timed out".

An IP address that is in-use and working will show replies (Reply from 10.30.100.170:....)

Check with your IT support person for help with these settings.

5. Using a Cat5 network cable, connect the printer to your network via the Ethernet port.

SECTION 2 INSTALLING THE PRINTER

6. Open the **Printer Toolbox**. Select the **“View”** drop-down menu. Select **“Service Menus”**. The **“Service Menus, “Diagnostics”** window will open, displaying a lot of information about the printer. This information will include the Network Status and configuration settings.

ONLINE View Maintenance Service Print

Diagnostics

System Settings

Scan Sensors

Service Menus

Password

Submit

Diagnostics

System Name: M_Series
Serial Number: SG233Z401689
Firmware Released: 20171212
Firmware Version: R15.0pre14-AMC1
Internal Memory (MB): 128
Total Pages 1600x1600: 199
Total Pages 1600x800: 14180
Tilt: FB=0.6 LR=0.0

Printhead Id: B00C0L9
Printhead Pages: 4335
Printed Ink (µL): 200358
Cyan: 91% (S1701108430448)
Black 2: 98% (S1718809260492)
Yellow: 60% (S1434209130086)
Magenta: 89% (S1500911250367)
Black 1: 71% (S1706711080398)

Network Status: connected
MAC Address: 84-97-b8-01-39-5e
Printer Name: MemJeff
Domain Name: astromachine.com
DHCP: Disabled
BOOTP: Disabled
AutoIP: Disabled
DHCP Lease Time (s): 0

IP Address: 192.168.254.119
Subnet Mask: 255.255.255.0
Default Gateway: 192.168.254.254
WINS Server: 192.168.254.11

Upload Debug Log

NVM Settings
mpcarev : 5
nomech : 0
pp_tof : media_gap
pages per cut : 0

VARS Settings
recovery_mode : 0
tof_adjustment : 0
bof_adjustment : 0
bof_allowance : 0

7. If the **“Network Status:”** is shown as **“disconnected”**, click on the refresh button in the browser window. If you have entered compatible network settings for your network and the printer, the **“Network Status:”** line in the **Diagnostics** window

should change from **“disconnected”** to **“connected”**. If the status doesn't change to **“connected”** please contact your IT support person for help with the network settings.

8. Run the Printer Software (M Series Driver1) installation again, but this time choose: **“Add another printer”**.

9. When prompted to choose the Printer Connection, select **“Configure to print over the Network”**. Then click **Next**.

The install program will search the network for printers. It should automatically locate the **“M Series”** printer at the IP address provided by the network or that you configured in step 4.

In this example the **“M Series”** printer has the IP Address 10.30.100.169.

Note: If the driver install program cannot locate the printer automatically, then you will be presented with a window to enter the Host name and IP Address for the printer. Enter the IP Address for the printer and click Next (You do NOT need to enter a Host name). If the printer is found at the IP Address provided, the driver install will continue automatically (*skip to 10*).

If the printer is not found then, in general, you have not provided a valid IP Address or network configuration for the printer. In this case **CANCEL** the driver install and repeat from **Step 2**. Please obtain help from your IT support people.

10. Select the **“M Series”** printer that is displayed. Then click **Next**

11. When the **“Finished software installation”** window appears, displaying **“Network Connection Successful”**, select if you want to **“Print Test Page”** or **“Set this printer as the default printer”**. Then click **Finish**.

If selected, a test page will be sent to the printer to be printed.

Tip: To help distinguish between multiple M-Series Drivers on your system, Open the **“Printers and Faxes”** (Devices and Printers) folder. Then rename the network configured printer **“M Series Driver (Network)”** and the USB configured printer **“M Series Driver (USB)”**.

Opening (launching) the **“Toolbox”** utility over an Ethernet connection:

To open the Toolbox utility, click on Start, All Programs, Memjet, M Series Driver, Toolbox.

If you have more than one copy of the M-Series Driver installed, you will be prompted to choose the device you want the Toolbox to connect to. Be sure to choose the proper device.

Example:

M-Series Driver - configured for USB. Suggestion: Rename to **“M Series Driver (USB)”**

M-Series Driver (Copy 1) - configured for Network. Suggestion: Rename to **“M Series Driver (Network)”**

Installing the Ink Tanks

The MACH 5 printer uses five Ink Tanks (two Black, one Cyan, one Magenta, and one Yellow). The Ink Tank is a delicate, precision device. Handle with extreme care to avoid damage.

Ink Tank Anatomy

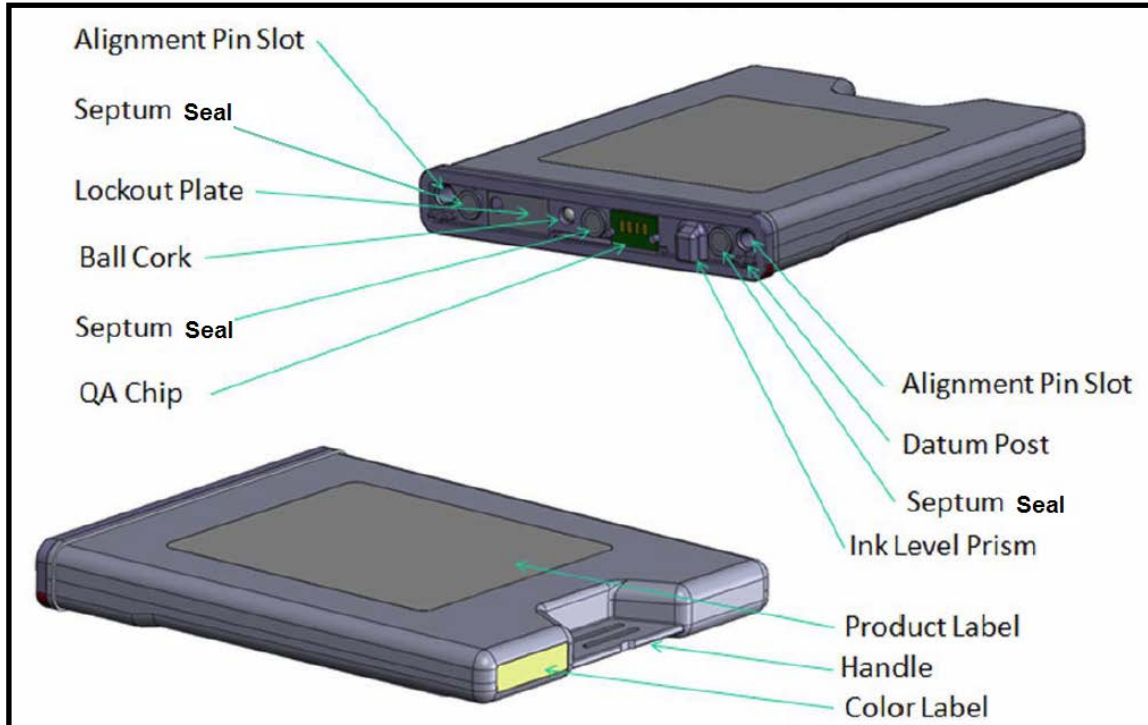

The ink used in this system may be harmful if swallowed. Keep new and used printhead cartridges and ink tanks out of reach of children. Discard unwanted printhead cartridges and empty ink tanks immediately.



Before attempting to install or remove Ink Tanks, press the button labeled “Replace Ink Tanks” in the Toolbox, or Power-down the printer using the ON/OFF button. If this rule is not followed the QA Chip on the Ink Tank may be damaged, which will render the Ink Tank unusable.

SECTION 2 INSTALLING THE PRINTER

Procedure (Installing the Ink Tanks):

This procedure assumes that you are installing Ink Tanks into a printer that doesn't have any Ink Tanks installed. If you are replacing an empty Ink Tank, please refer to the "Replacing the Ink Tanks" section.

Install the Ink Tanks as follows:

1. **Power the Printer ON.** Plug in the printer. Turn the printer's Main Power Switch ON, then press the control panel's ON/OFF button. Wait about 45 seconds for the print engine to power-up (ON/OFF button will illuminate).
2. **Open the M Series Toolbox.** Go to All Programs, select the "Memjet" folder, select the "M Series Driver" folder and Open the "Toolbox".
Tip: If you receive warning that Windows Firewall has blocked some features of this program. Please select Private Networks and then click on **Allow Access**.

A web browser will open and display the "System Status" screen. On the left side of the screen, you will see information about the System Status and Ink levels. With no Ink Tanks installed all Ink status levels for "C, K2, Y, M, K1", will be displayed with a question mark (?) below each color position and the colors are not filled in.

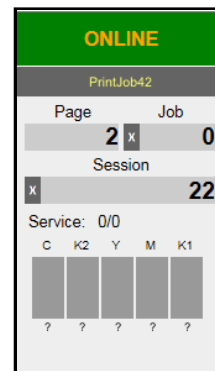

3. **Select "Replace Ink Tanks" from the "Service" drop-down menu.** This disconnects Printer communication with the Ink Tanks and allows safe installation and replacement.

Once the "Confirmation" window opens, it is safe to install the Ink Tanks.
IMPORTANT: DO NOT press "Continue" until after you have installed the Ink Tank(s) and closed the Ink Tank Latches.

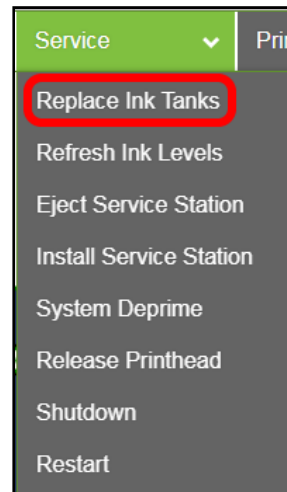

It is now safe to install/remove the Ink Tank(s).
Do not press "Continue" until Ink Tank replacement process is completed.

Continue

4. **Open the Ink Tank Door**
(*hinged at bottom*).
5. **Open all three Ink Tank Securing Latches [A].**
6. **Remove the new Ink Tank(s) from packaging.**

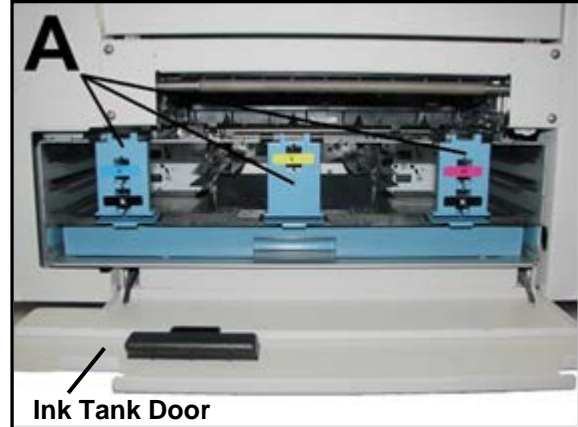

7. **Insert the new Ink Tanks (*labels up*) into their appropriate color slots [B].**

CAUTION! Be sure each Tank is installed into the proper color slot. If you force the Ink Tank into the wrong slot, you will contaminate the ink system and professional service will be required.

INSTALLATION TIP: To help ensure that the Ink Tanks are seat properly. Insert the Ink Tank into the appropriate Ink Station, then pull the Ink Tank back about an inch and push forward firmly. This will help ensure that the “septum needles” penetrate the seals on the Ink Tanks.

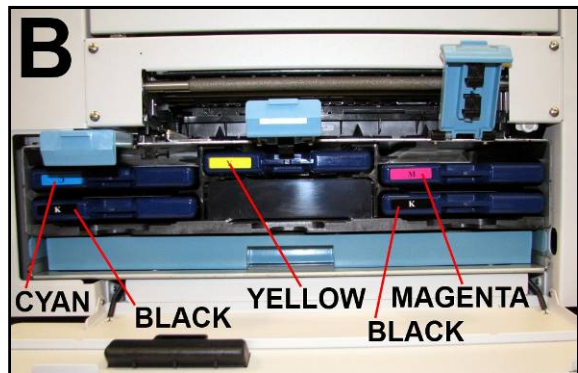

8. **Close and Lock all three Ink Tank Securing Latches.**

IMPORTANT: Make sure both sides of the Latch are engaged at the bottom.

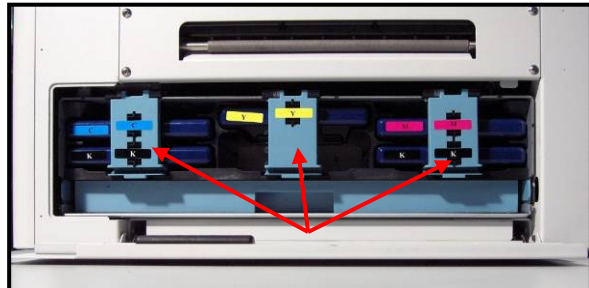

9. Click “Continue” on the “Confirmation” window.

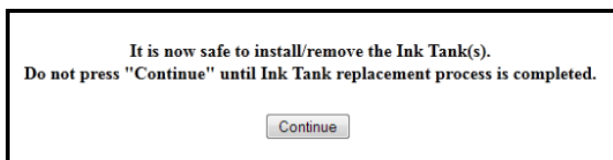

SECTION 2 INSTALLING THE PRINTER

10. Watch the Toolbox screen on your computer.
You should see all the ink colors fill-in, if all the Ink Tanks are properly installed and recognized. **NOTE:** The image to the right shows used Ink Tanks installed. New Tanks should read 99%.

TIP: If an Ink Tank color does NOT fill-in and a question (?) mark or “Out” or “0%” condition is displayed below the ink color, this indicates that the printer does not recognize the Ink Tank (Unable to communicate with QA Chip), or the ink level sensor doesn’t see any ink in the Tank.

If this issue occurs:

- a. Verify that the Ink Tank Securing Latches are fully closed and locked.
 - b. Select “**Refresh Ink Levels**”.
 - c. If the ink color still does not fill in, the QA Chip contacts, or Ink Level Prism may need to be cleaned. Please refer to the “**Operator Maintenance**” section for information on “**Cleaning Ink Tank Contacts & Prism**”.
- Tip:** Even new Ink Tanks can have dirty QA Chip contacts.

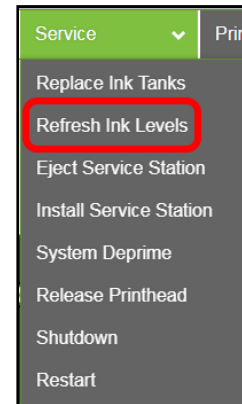
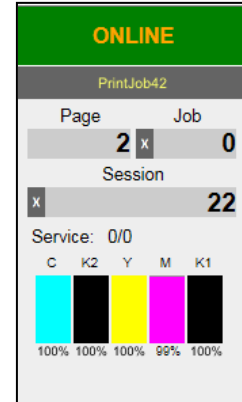

11. Close the Ink Tank Door.

NOTE: If a Printhead Cartridge is not installed, the **Systems Status** screen in the **Toolbox** will display the “**PRINTHEAD_MISSINGQA**” message. To install the Printhead Cartridge, please proceed to the section titled “**Installing the Printhead Cartridge**”.

WARNING!

The ink in the Ink Tanks may be harmful if swallowed. Keep new and used Tanks out of reach of children. Discard empty tanks immediately.

Installing the Printhead Cartridge

The MACH 5 printer uses a single Memjet® printhead cartridge.
The Printhead Cartridge is a delicate, precision device. Handle with extreme care to avoid damage and issues that could degrade print quality.

ATTENTION

If you experienced fuzzy print quality or an abrupt failure in a particular area of nozzles on the previous printhead, we recommend that you have the service station inspected/cleaned and the wiper roller replaced before installing the new printhead. Failure to do so will increase the chance of damage to the new printhead. Service station maintenance and wiper roller replacement should only be performed by a qualified/trained person. Please contact your service representative to obtain training or to have them perform this process for you.

Protective Packaging

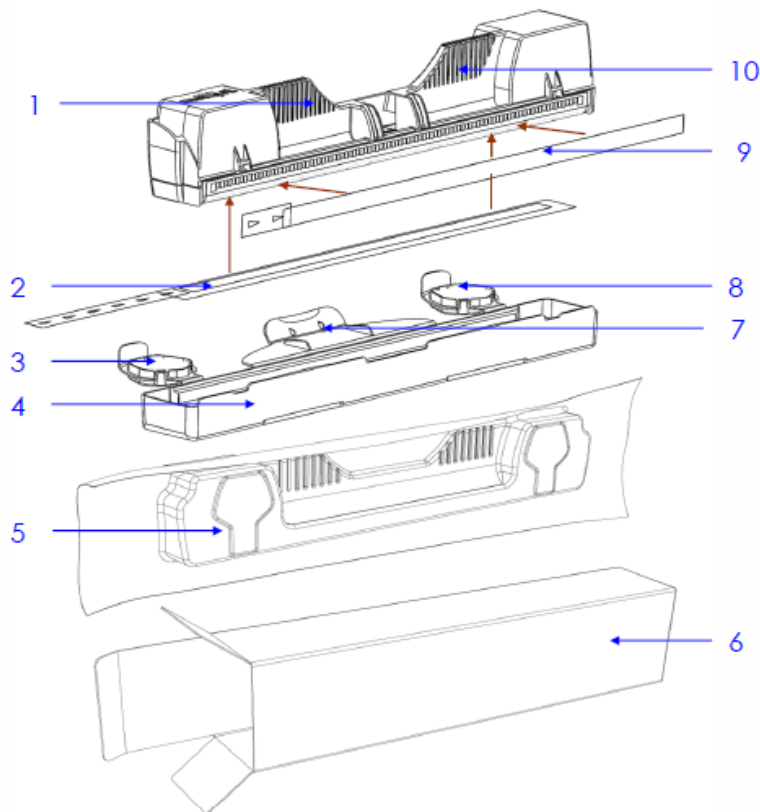

- | | | | |
|--------|-------------------------|---|--------------------------|
| 1 & 10 | Handles | 5 | Foil vacuum bag |
| 2 | Nozzles protective tape | 6 | Cardboard packing box |
| 3 & 8 | Protective cover flaps | 7 | Cover retaining clip |
| 4 | Protective cover | 9 | Electrical contacts tape |

NOTE: Discard protective tape once it is removed. Do NOT reuse protective tape.
Keep all other packaging to store/dispose of old printhead cartridge.



The ink used in this system may be harmful if swallowed.
Keep new and used printhead cartridges and ink tanks out of reach of children.
Discard unwanted printhead cartridges and empty ink tanks immediately.

SECTION 2 INSTALLING THE PRINTER

CAUTION

- Use electrostatic discharge (ESD) handling precautions.
- Hold the Printhead Cartridge by the handles **ONLY**.
- **DO NOT** touch the Ink Couplings, nozzle surface or electrical contacts.
- **DO NOT** unpack the Printhead Cartridge until the Printer is ready for installation. Once unwrapped, delay in installing the Printhead can compromise print quality due to dehydration.
- **DO NOT** place an unwrapped Printhead on any surface before installing. Always protect the Printhead from dust, fibers, dirt, and other contaminants.

CAUTION

DO NOT PRY OR MANUALLY LIFT THE PRINTHEAD LATCH OR THE LATCH WILL BREAK. ONLY OPEN THE LATCH USING THE RELEASE PRINTHEAD BUTTON ON THE PRINTER OR IN THE TOOLBOX.

NOTICE! Read this procedure, in its entirety, before proceeding!

Before you begin this process, you will need to obtain some deionized or distilled water and some lint free cloths. These items will be used to wet the printhead nozzles.

NOTE: Do NOT use tap water or paper towels to wet or clean the printhead nozzles. Doing so may cause damage to the printhead cartridge and possible contamination to the ink system.

The printhead cartridge and ink supply must be within the operating temperature range ((+15°C to +35°C (59 °F to 95 °F)), before attempting to prime the cartridge with ink and starting to print. When stored at temperatures below the operating range it may take up to 3 hours for a cartridge in its packaging to reach operating temperature.

NOTE: Additional packaging will increase the time needed to reach operating temperature.

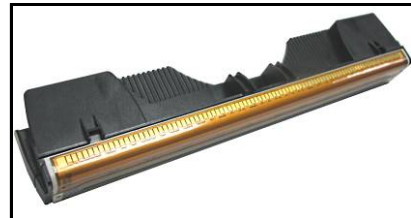

Why is it necessary to wet the printhead nozzles?

During the priming process a vacuum is created by the pump, to pull ink from the Tanks into the printhead and ink delivery system. If the printhead nozzles are dry (open), air is pulled in through the printhead nozzles causing the priming process to fail (pump is unable to create a vacuum). By wetting the printhead nozzles this creates a temporary “water seal”, which prevents air from getting pulled into the printhead during the priming process.

Procedure (Installing the Printhead Cartridge)

This procedure assumes that you are installing a Printhead Cartridge into a printer that does NOT have a Printhead Cartridge installed. If your printer already has a Printhead Cartridge installed, and you wish to replace the Printhead Cartridge, please refer to the section titled “Replacing the Printhead Cartridge”.

1. Plug in the printer. Turn the printer’s Main Power Switch ON, then press the control panel’s ON/OFF button. Wait about 45 seconds for the print engine to power-up (ON/OFF button will illuminate).
2. If the Printhead Latch [2] is closed, press the “Printhead Latch Release” button [1], as shown. Use a non-metallic item (example: plastic pen) to reach through the hole and lightly press the button.

The printer will run a routine and then the Printhead Latch [2] will release so it can be opened.

Note: The Printhead Latch [2] color may be blue or black.

WARNING! If the printhead latch fails to release do not force the latch open. Severe damage will result.

Tip: You can perform this same function from your computer by selecting the “Service” drop-down menu in the **Printer Toolbox**. Then select “**Release Printhead**”.

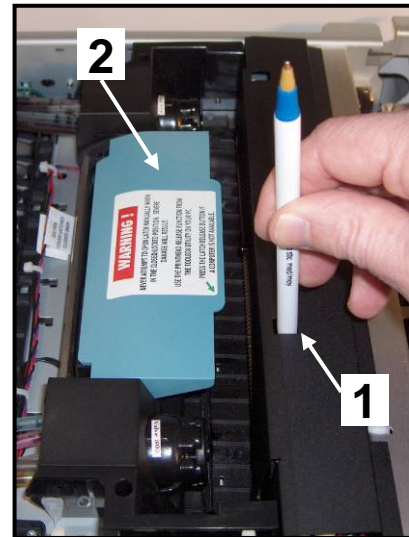
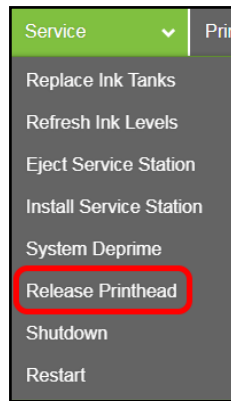

3. Open the Printhead Latch fully.
4. If present, **Remove the Cap Protectors [3]** from the Ink Revolver Couplings. Save these items. They should be used to seal and protect the open ink system when a Printhead Cartridge is not installed.

NOTE: Before replacing or reinstalling a Printhead Cartridge, please clean the Ink Revolver Couplings. See section titled “Cleaning the Ink Revolver Couplings”.

CAUTION

DO NOT PRY OR MANUALLY LIFT THE PRINTHEAD LATCH OR THE LATCH WILL BREAK. ONLY OPEN THE LATCH USING THE RELEASE PRINTHEAD BUTTON ON THE PRINTER OR IN THE TOOLBOX.



SECTION 2 INSTALLING THE PRINTER

5. [A] Carefully remove the Printhead Cartridge from the foil packaging. Tear at notch or cut end with scissors.

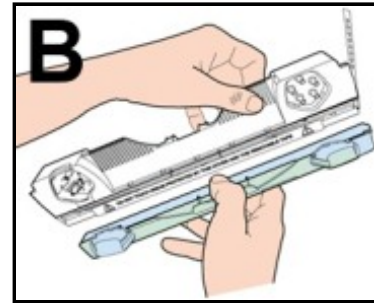
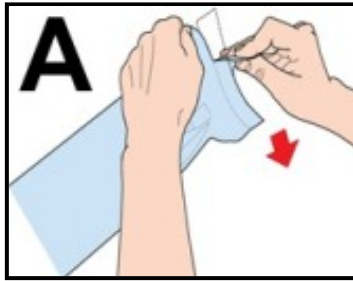

- [B] Remove the protective plastic cover. Hold the Printhead by the handle and unclip the cover from the Printhead.

- [C] Remove protective strip from the Printhead Electrical Contacts. DO NOT allow removed strip to touch the electrical contacts.

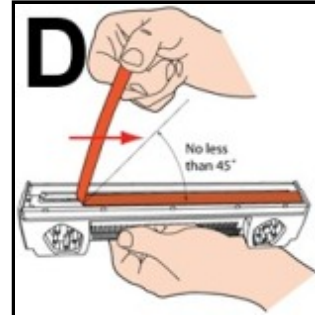
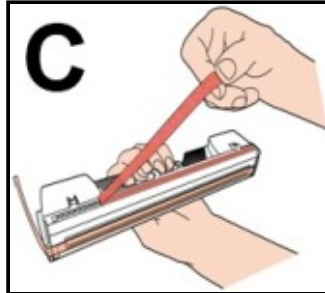

- [D] Remove protective strip from the Printhead Nozzles. Hold the

Printhead by the handle. Pull the strip tab and slowly peel the strip from the Printhead.

- DO NOT pull the strip at less than a 45° angle from the Printhead surface.
DO NOT allow removed strip to touch the Printhead Nozzles.

WARNING

TO AVOID ELECTRICAL SHOCK OR SHORTING
Before installing the Printhead, make sure the contacts are DRY!

6. Carefully insert the Cartridge into the compartment at an angle [4], with the Printhead surface facing down and the Ink Couplings facing the Ink Revolver Couplings (ink hoses). Once it is seated, gently tilt the Cartridge forward until it snaps into an upright position [5]. DO NOT FORCE the Cartridge into position. DO NOT close the Printhead Latch at this time.

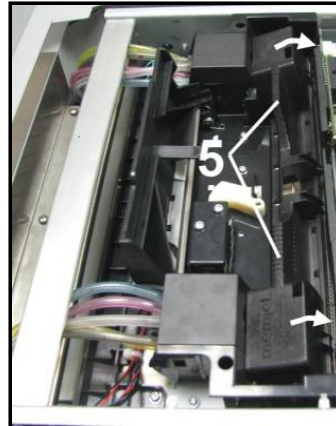
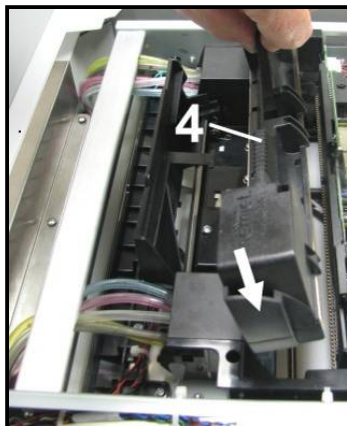

7. Open the Print Engine Clamshell.

Use both hands to release both latches at the same time.



8. Using a lint-free cloth soaked with deionized or distilled water, wet the entire Printhead Nozzle area.

Be liberal with the amount of water you leave behind on the nozzles (the thin dark line on bottom of printhead cartridge). See images below.



WARNING: Be careful not to damage the “star rollers” when wiping the printhead. These rollers are designed so they can roll across a wet image, without damaging the image. If the rollers are bent, they will not turn free, causing media feed issues (jamming) and possible damage to the image or media.



9. Immediately after wetting the nozzles. Carefully close and latch the Print Engine Clamshell.

CAUTION

USE TWO HANDS TO RELEASE BOTH LATCHES, WHILE OPENING AND CLOSING THE PRINT ENGINE CLAMSHELL.

DO NOT OPEN THE CLAMSHELL DURING THE PRIMING PROCESS.

10. Now close the Printhead Latch [6]. After a few seconds the Printer will run a “priming routine” that fills the ink system and Printhead with ink.

WHAT TO EXPECT:

- a. After closing the Printhead Latch there will be a ~10 second pause (no noise or motion).
- b. Then you will hear the Service Station move to the capping position.
- c. Then you will hear the ink pump start to run.
- d. At this time, ink should start flowing through all the tubes, in and out of the printhead. If you see this occurring, then the priming process is working.
- e. This priming and head cleaning process will continue, off and on, for about 5-6 minutes.
- f. Two times during the priming process you will hear a high-pitched screech, lasting ~1 second, from the pump. This is the “pressure prime” process. This process is used to help force air bubbles and blockages from the nozzles.

WARNING! To avoid the possibility of causing an accidental “ink mess”, inside the print engine, it is important that you do NOT open the clamshell during this process.



SECTION 2 INSTALLING THE PRINTER

If you reach the end of the priming process and the printhead failed to prime (one or more of the ink tubes have not filled with ink):

- i. Release the printhead (using the **Release Printhead** feature from the **Toolbox**),
- ii. Once the latch opens, carefully retract the latch fully.
- iii. Release the printhead from the electrical contacts by tilting it back, but don't remove the printhead.
- iv. Tilt the printhead forward to reconnect it to the electrical contacts.
- v. Repeat the process from **Step 7**. See **Caution** below.

CAUTION

DO NOT REPEAT THIS PRIMING PROCEDURE MORE THAN TWICE IN A ROW. DAMAGE TO THE INK SYSTEM MAY RESULT. AFTER TWO ATTEMPTS, LET THE PRINTER SIT FOR AT LEAST 1 - 2 HOURS BEFORE YOU ATTEMPT TO PRIME THE PRINTER AGAIN. CONTACT TECHNICAL SUPPORT FOR ASSISTANCE IF PROBLEMS PERSIST.

11. Once the printhead priming process is successful (all ink tubes are filled, in and out of the printhead), it will take an additional 5 - 6 minutes for the printer to complete the process. During this time the printer will emit several chirps, whirrs, and other noises.

12. **Open the Toolbox System Status screen.** Notice some information is in *red*. As Printer circulates ink and primes system, these fields should turn *black*. This may take a few minutes. Check that the Printhead icon [7] in Printer image is primed (*solid color*).

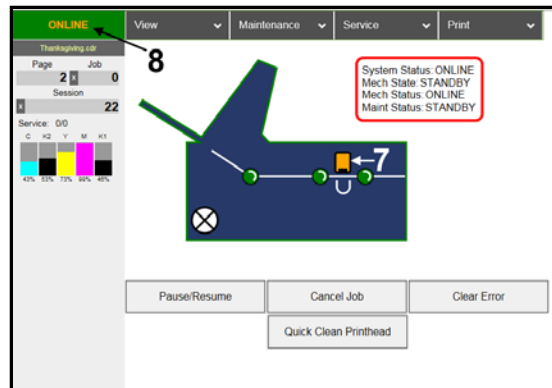

13. When the printer stops processing, **ONLINE** [8] appears, and all the fields in **System Status** are black, the printer is ready for use. You will also observe the following printer Control Panel condition: ON/OFF button light ON, Paper/Resume light OFF, Pause/Cancel light OFF. **NOTE:** If the Printhead icon continues to display an outline or a question mark (?) try these procedures:

[1] **Printhead icon shows an outline (Printhead unprimed):** Click “**Circulate Ink**” under “**Maintenance**” drop-down in Printer Toolbox. If issue persists, try the “**Install Printhead**” procedure again. If the issue continues, contact technical support.

[2] **Printhead icon displays a question mark (Printhead not recognized):** Try the “**Install Printhead**” procedure again. If the issue continues, contact technical support.

NOTE: If any Ink Tank is less than 30% full, the Printhead Cartridge priming process may fail (not enough ink to completely fill the system). In this case you will need to replace the tank(s) containing low ink and repeat the printhead priming process. After the Printhead is primed, you can reinstall the original Ink Tank(s) to use up any remaining ink. Please refer to the section titled “**Replacing the Ink Tanks**”.

IMPORTANT! Whenever a printhead cartridge is installed or reinstalled, it is possible that there will be excessive ink build-up on the Printhead surfaces and the lip of the Service Station Cap. Before starting to print a “live job”, it is strongly suggested that you manually wipe any excess ink from the Printhead surface, Envelope Printing Attachment Guide and Service Station Cap. Please refer to the sections titled “**Inspecting & Cleaning the Lip of the Capping Station**” and “**Manual Printhead Cleaning**”, for details on performing these procedures.

In addition, whenever a printhead cartridge is installed or re-installed, it may need to be conditioned to perform properly. Before printing a live print-job, please refer to the section titled “**Printhead Cartridge Conditioning**”.

14. **Close the Top Cover.**

Envelope Printing Attachment Kit

The Envelope Printing Attachment Kit (42-900-55, A0012908) is included with the printer.

Kit Includes:

- Head Media Guide (1)
- **Left-hand (large) PPS Spacer (1)**
- **Right-hand (small) PPS Spacer (1)**

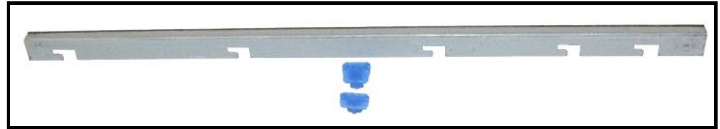

The Head Media Guide is used to flatten the media, as it enters under the printhead, to help reduce media contact with the printhead.

The PPS Spacers are used to increase the gap between the printhead and the platen, to further reduce the chance for media contact with the printhead. They are most useful when feeding envelopes, flap-first. The PPS Spacers give the flap a place to drop down into as the envelope travels under the printhead, thereby reducing the upward force that the flap commonly creates.

The most common head to media contact areas are the high points (bows, bends, flaps) on the media and the trailing edge of the media, since there is no control over the media lifting once it leaves the Head Media Guide.

If the media makes contact with the printhead this may result in:

- Scuff Marks - black streaks deposited on surface of media
- Smearing/Smudging of wet image, which can also deposit additional ink on the printhead surface, increasing the chance for additional scuff marks.

See section titled “Troubleshooting Guide” for more info on scuff marks and how to reduce.

Installing/Removing the Head Media Guide

This item is normally pre-installed in the printer. In general, the Head Media Guide can be used at all times. However, if you are primarily printing on thin, flat stock and you are encountering print quality issues (image distortions, image not as sharp as expected), you can remove the Head Media Guide to see if this has any effect. Occasionally, it may be necessary to remove the Head Media Guide to clean the guide and printhead surfaces.

Items Needed for Install: **Nitrile powder-free gloves, distilled water and lint free cloth.**

1. Open the Top Cover
2. Open the Print Engine Clamshell.

CAUTION
HOLD ONTO BOTH LATCHES
WHEN OPENING AND CLOSING
THE PRINT ENGINE CLAMSHELL.

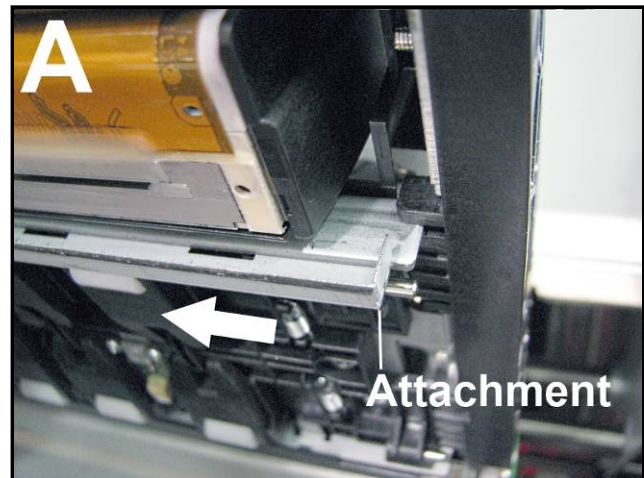

SECTION 2 INSTALLING THE PRINTER

3. [A] & [B] Start with the Head Media Guide positioned as shown in “A”, on previous page.
Note: The “Tab”, on the end of the Guide, fits over the front side of the metal “Support” plate.
While lightly pressing up on the Guide, slide it to the left, until the cutouts in the Guide aligned with the ears on the back side of the metal “Support” plate. This will allow the Guide slide up closer to the printhead surface, as shown in “B”.

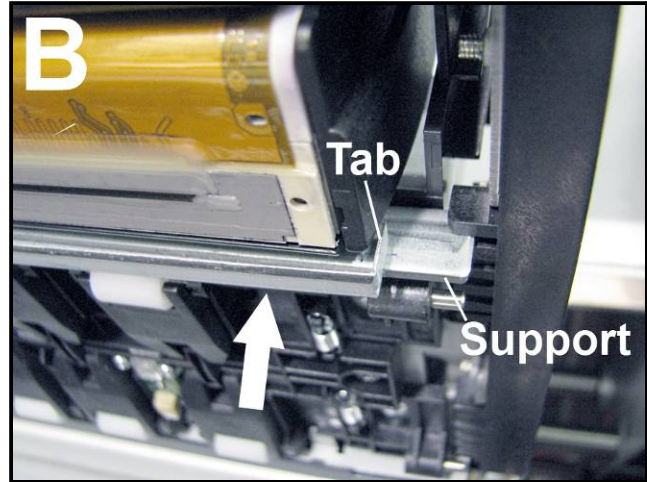

[C] Push the Guide to the right, to lock it in place.

NOTE: While the Clamshell is still open, verify that the Head Media Guide is aligned with the Printhead Cartridge as shown in “C”.

4. Once the Head Media Guide has been installed, Wipe the Printhead Nozzles end to end using distilled water and a damp lint-free cloth.
5. Carefully close and latch the Clamshell. Then close the Top Cover.
6. Remove in reverse order.

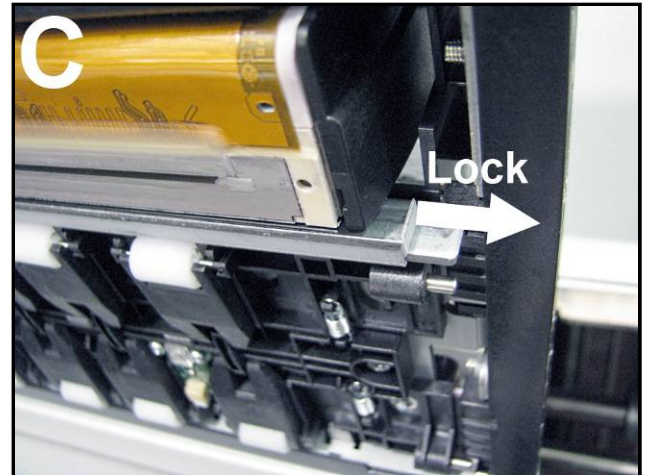

Installing/Removing the PPS Spacers

The PPS Spacers are designed to be used in conjunction with the Head Media Guide. They commonly come pre-installed in the printer.

With the PPS spacers installed and the clamshell closed, the spacers make contact with both ends of the printhead cartridge, which pushes the Platen down a small amount. This creates a larger gap between the printhead and Platen, thereby reducing the chance of contact between the media and the printhead.

Install the PPS Spacers if you are printing on media that is uneven (i.e., envelopes).

Remove the PPS Spacers if you are primarily printing thin flat stock (sheet stock).

Do NOT use the PPS spacers without the Head Media Guide.

Items Needed for Install/Removal: Nitrile powder-free gloves, distilled water, and lint free cloth. Small, flat-bladed screwdriver.

Install:

1. Insert the smaller PPS Spacer into the hole in the Platen [A], as shown.
2. Insert the larger PPS Spacer into the hole in the Platen [B], as shown.
3. Make sure the PPS Spacers are fully inserted.
4. Wipe the Printhead Nozzles end to end using distilled water and a damp lint-free cloth. Carefully close and latch the Clamshell. Close the Top Cover.

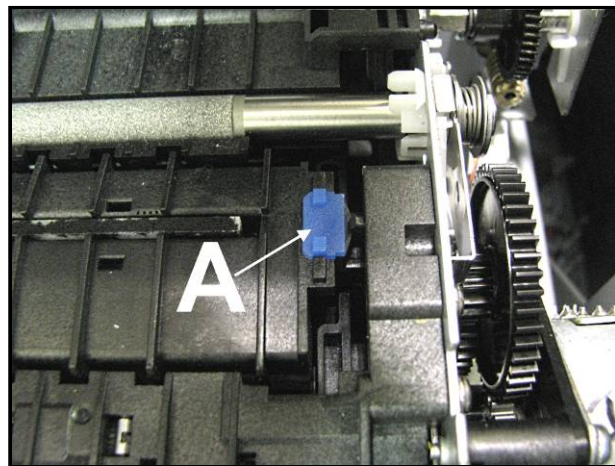

Remove:

1. Carefully pull out the smaller PPS Spacer from the hole in Platen [A]. You may need to use a small, flat-bladed screwdriver to get under the spacer, to lift it up.
2. Carefully pull out the larger PPS Spacer from the hole in the Platen [B].
3. Wipe the Printhead Nozzles end to end using distilled water and a damp lint-free cloth. Carefully close and latch the Clamshell. Close the Top Cover.

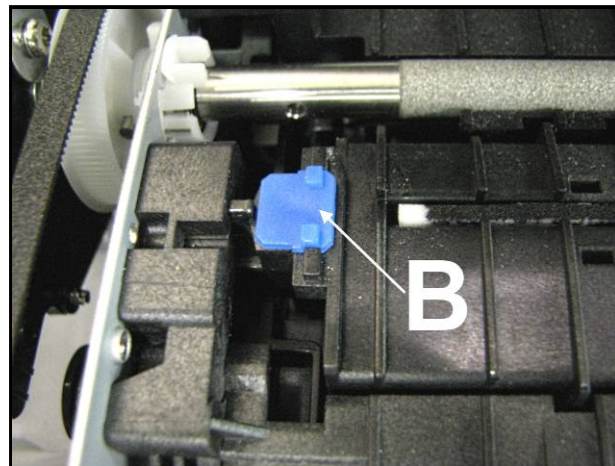

TECH NOTE: When replacing the Service Station, Do NOT discard the two PPS Spacers. Remove and save or reuse in new Service Station.

Additional things that may help reduce scuff marks and image smudging/smearing:

- Check to be sure the Head Media Guide is properly installed. Try adding/removing "PPS Spacers".
- Check to be sure the Head Media Guide, printhead, lip of cap (capping station) and other surfaces are clean. Clean using distilled water and a lint free cloth.
- Try feeding the media in a different orientation. Rotate piece 90, 180, 270 degrees.
- Try to use media that is flat (not warped, bowed, or bent). Be sure flaps are folded crisply.

Section 3 – Operating the Printer

Setting up the Feed

The MACH 5 printer is equipped with four sheet separators, two side guides, a rear media support guide and two different sized media support wedges. When properly adjusted these items will separate and guide the media so that only one piece of media is fed into the print engine at a time.

1. If not already present, install the appropriate Media Support Wedge onto the Rear Media Support Guide, using the mounting hardware [4] provided.

Wide Media Support Wedge

– For media that is 8 to 9.5 inches wide.

Narrow Media Support Wedge

– For media that is 3 to 8 inches wide.

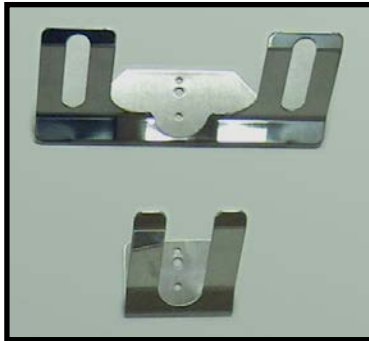

2. Select the appropriate position for the Media Registration Side Guide.

This guide has two positions.

- Inner position for media measuring 3" to 8.5" in width.

- Outer position for media measuring 8.6" to 9.5" in width.

Loosen the locking knob and move the Media Registration Side Guide into the desired position (Inner or Outer). Then tighten the locking knob to secure the guide.

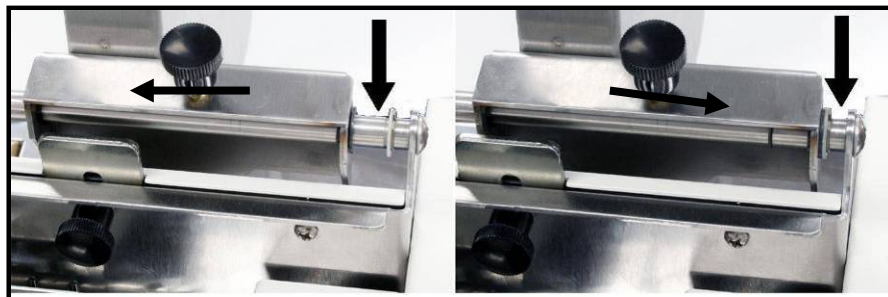

Inner Position
(3" to 8.5" wide media)

Outer Position
(8.6" to 9.5" wide media)

As viewed from the exit side of the media side guide and separation area.

3. Loosen the locking screws, located behind the sheet separators, and raise the separators. Then tighten the locking screws to hold the separators in the up position.



4. Place a single piece of the media, to be run, under the separators. Always place the media against the Media Registration Side Guide.
5. Loosen the separator locking screw and allow the separator to settle onto the media. Then tighten the locking screw. Repeat for each sheet separator.



IMPORTANT

Be sure that unused separators are locked in their raised position. If not, they will rub on the feed rollers, causing transport problems and damage to the rollers and separators.

6. Loosen the locking knob and reposition the Adjustable Media Side Guide so that it is about 1/32-inch from the side of the media. Then tighten the locking knob to secure the side guide.
Tip: If you have trouble moving the Adjustable Media Side Guide closer to the non-operators side of the printer, check to be sure the Rear Media Support Guide is not getting in your way.



SECTION 3 OPERATING THE PRINTER

7. Adjust the position of the Rear Media Support Guide, so that it is centered under the width of your media. This guide slides side to side.

Tip: The Rear Media Support will slide, without loosening the knob.

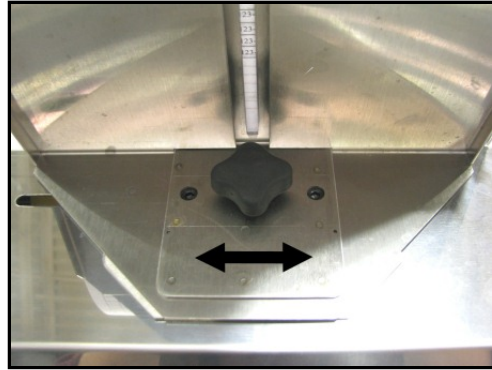

8. Adjust the position of the Media Support Wedge to accommodate the length of your media. Place a second piece of media onto the single piece that is already in the hopper. Make sure the second piece of media is against the separators. Loosen the locking screw and reposition the wedge so the trailing edge, of the second piece of media, is hitting the bend in the wedge, as shown

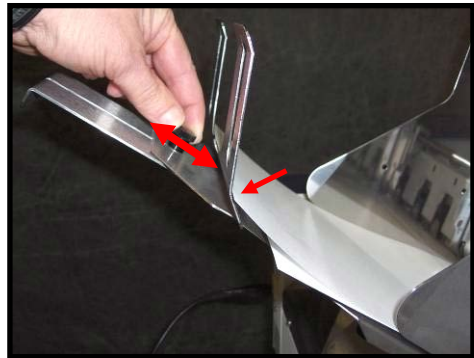

9. Place a stack of media into the hopper. Make sure that the stack is fanned so the bottom piece is closer to the separators than the top pieces.

Tip: When loading an empty hopper. Place one piece of media so it is directly against the tips of the separators. Then place the fanned stack of media on top of this single piece.

NOTE: The amount of media that can be stacked on the printer is determined by the weight of the material. The feed section may not feed larger and heavier media when the stack is full. If this is the case, reduce the amount of media in the stack until the media feeds properly.



10. Paper Feed Test. To check for proper media separation and feeding. Turn the printer's Main Power Switch ON, then press the control panel's ON/OFF button. Wait about 45 seconds for the print engine to power-up (ON/OFF button should illuminate). Press and hold the Paper button for 5 seconds. The printer will feed one piece of media through the printer.



Printer Driver Properties

Valid for M Series Driver version R15

NOTE: The R15 Driver was developed for use with printer firmware version 20180323. They must be used as a set. If you try to use this Driver with other printer firmware versions, some of the Driver properties/features may not work.

New User Tip: When you are first learning how these Driver features effect the image orientation and position, it may make more sense to load 8.5 x 11 media into the printer and print a single page after each change you make to the Driver settings. If you follow this process, you will be able to see more of the image (which may print off the side of a smaller media) as well as the orientation and position of the image. Once the proper image orientation/position is achieved, load your desired media to match the orientation of the image.

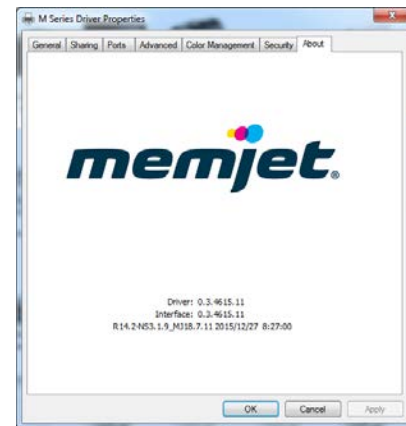

The Printer Driver for the M-Series Printer works similar to other Printer Drivers for Windows®. It does contain some features that are unique to this printer. The Driver properties/features are explained below.

Once the job is set-up in your Windows® program (Adobe Acrobat, Word, etc.), select **Print**. The window on the right will open.

Make sure the **M-Series Driver** is the selected Printer.

Clicking on **Properties** opens the “**M Series Driver Properties**” window, shown below.

General Tab

The **General** tab lets you select:

- **Orientation** – Portrait (Default), Landscape, Rotate 180° and Mirrored.
Tip: Instead of changing this setting from “portrait” to “landscape”, experiment with the drop-down list of Media “Size” selections (i.e., “6 x 9 in – Portrait” or “6 x 9 in – Landscape”) to match the printed image orientation to the actual orientation of how the media is being fed into the printer.

- **Page Buffering** –
If **Buffer** is **checked**, the entire print job will be spooled before it is sent to the printer. This will increase the time it takes for the job to start printing, but it may also reduce the chance of the printer pausing to wait for data and or displaying “**DATA_PATH_UNDERRUN**” in the Toolbox.

- **Mask Optimization** (checked is default) - Optimizes images for printing in most applications. For some printing applications, printing artifacts (faint lines) may still appear in the output, when “Mask Optimization” is selected. If this happens, deselect (uncheck) “Mask Optimization” which usually corrects the issue. (Remember to check/uncheck box when changing applications.)

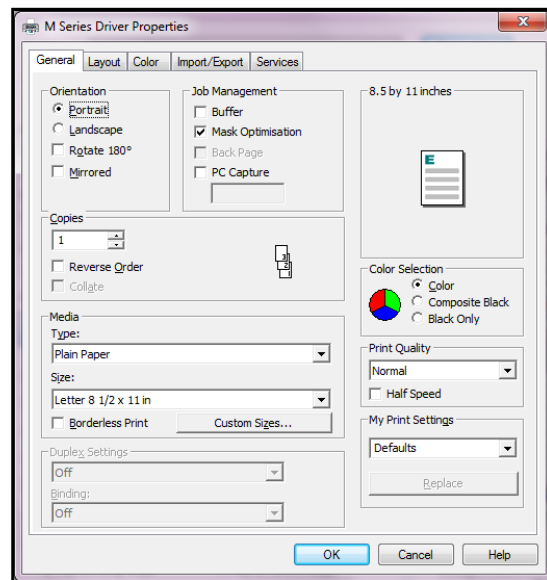

**SECTION 3
OPERATING THE PRINTER**

- **Back Page** – Unavailable unless Printer is attached to “Duplex Unit” (*MACH 5DX*).
Used to load a static (unchanging) “back page”, which will be stored and reprinted onto every piece that is fed into the Duplex Unit.
- **PC Capture** – When checked, saves a Print File (*.prn) on the PC (C:\Windows\Temp) for later use. (*Unchecked is default.*) **NOTE:** Use the box below the selection to name the file, otherwise the Printer assigns the current date and a numerical name.
- **Copies** – Lets you choose the number of copies to be printed.
NOTE: This Driver version has a limit of 32,767 copies. However, in some cases, copies are limited by the software program. For example, Adobe Acrobat® limits copies to 999.
- **Reverse Order** – Lets you choose the order of how the pages will be printed.
If un-checked (default), the job will start printing with the first page. Printing starts as soon as the first page loads.
If checked, job will start printing from the last page. Since the entire job must be spooled, before being sent to the printer, it may take a while for the job to start printing.
- **Collate** – only available when “copies” is set to 2 or more.
If un-checked (default), each page will be printed with the selected number of copies before the next page is printed.
If checked, copies will be grouped into sets (in page order).
- **Media** – Select Type and Size. Add Custom Size.

- **Type:** Selecting the appropriate Media Type (media profile) may help you achieve better color accuracy results. Chart at right lists the “media types” associated with each of the “media profiles”.
TIP: mColor (RIP and Workflow) software is available if you require better “color management” options. Please contact your dealer for more information on “mColor”.
- **Size:** Select the media size you are using, from the pull-down list. If the size is not present, use the “Custom Sizes” feature.
Tip: Some common Envelope (Env.) selections are provided for “portrait” and “landscape” orientations. Experiment with these selections to match the printed image orientation to the orientation of how the media is being fed into the printer.

MEDIA TYPE	MEDIA PROFILE
Plain Paper Bright White Paper Transparency Film	Plain Paper
Premium Photo Paper Glossy Photo Paper Glossy Label Glossy	Premium Glossy Label
Photo Greeting Cards Glossy Photo Paper Semi-gloss Postcards Glossy Brochure Glossy	Glossy Label
Photo Paper Matte Label Matte Photo Greeting Cards Matte Brochure Matte Premium Inkjet Paper Presentation Paper Other Inkjet Paper Postcards Matte	Matte Coated Label

- **Custom Sizes** – Use to create and save “custom media sizes”.
Range: Width: 3” (76mm) min to 8.5” (215.9mm) max.
Height: 4.2” (106.7mm) min to 30” (762mm) max.

NOTE: The security rights on some computer systems may prevent you from accessing or saving “Custom Sizes”. You may need “admin” rights to use this feature.

After defining a “custom media size”, enter your desired “Media Name” and press “Save”.

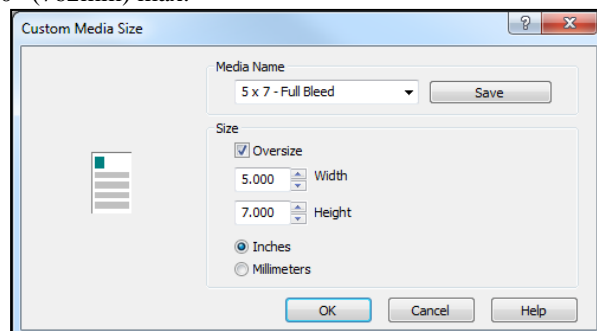

Tip: When defining the width of a “custom media size” that measures between 8.5 and 9.5 inches wide, please set the width to the max value (8.5”). If you want to take advantage of the full width of the printhead (8.77”), you must set width to 8.5” and select “Oversize”.

Example: #10 Env (9.5” W x 4.13”H), feeding long-edge first. Set dimensions to 8.5” W x 4.2” H.

Media Orientation Tip:

When defining a “custom media size”, be sure to set the dimensions to match the actual orientation of the media, as it is fed through the printer.

Examples: 5” x 7” envelope, fed long-edge first, would have the custom dimensions 7” W x 5” H
5” x 7” envelope, fed short-edge first, would have the custom dimensions 5” W x 7” H

Oversize – Select this box to enable “full bleed” printing (printing off all edges of media). When “oversize” is selected the “custom media size” you define is increased by ~0.12” in width and height, without affecting the values shown in the “Custom Media Size” screen.

To use the full width of the printhead (8.77”), you must set width to 8.5” and select “Oversize”
IMPORTANT! To take advantage of this feature, the image you send must be slightly larger (normally 1/8” wider and higher) than the “custom media size” you defined.

Full Bleed Example:

“Custom media size” defined as 8.5” W x 11” H and “oversize” selected. Media being fed measures 8.5” W x 11” H. Image being sent measures 8.625 W x 11.125 H.

Full Bleed Tips:

Be sure to create Custom Media Size in driver, for width of your media, and select “Oversize”. Make changes to the “left adjustment” and “top adjustment” features, located in the “Layout Tab”, as needed, to align the image with the media, so it bleeds equally off all edges of the media.

To avoid image expansion/distortion, please be sure to set/check the following:

- Layout Tab. “Resizing” should be set to “Original Size”.
- Adobe Acrobat. Select “Actual size” under “Page Sizing and Handling” in the Print box.

- **Borderless Print** – When using an image that is the exact same size as the media, this option can be selected to expand the image (21 dots in height and width), to help achieve “full-bleed” printing (printing off all edges of the media).
NOTE: If you want to do “full-bleed” printing but don’t want the image expanded/distorted, please use the “Oversize” feature, as defined under “Custom Sizes”.
- **Duplex Settings** – Unavailable unless Printer is attached to a “Duplex Unit” (MACH 5DX).
- **Color Selection** – Select from Color, Composite Black or Black Only.
 - **Color:** Selection provides full color printing using all five ink channels (CMYKK).
 - **Composite Black:** Selection uses all five ink channels (CMYKK), to generate the darkest black print possible, for the selected print quality. Color images are printed in “grayscale”.
 - **Black Only:** Selection uses only the native “K” (black) ink channels to print. Images printed with this selection will be “gray” in color. This is the “native” “K” (black) ink color. If you want a darker black, please select “Composite Black”. Color images are printed in “grayscale” using only the “K” (black) ink channels.
NOTE: Even if you select “Black Only” the system will still use a small amount of color ink (CMY) when performing head purge and head maintenance sequences. All Ink Tanks (CMYKK) must be installed and recognized as having ink available, or the printer will NOT function.
- **Print Quality** – Select Normal or Best.
 - **Normal** provides 1600 x 800 dpi at 12 ips (inches per second).
If you also select the **Half Speed**, box, media transport and printing is slowed to 6 ips, for higher print accuracy.
 - **Best** provides 1600 x 1600 dpi, at 6 ips. Use when high quality images are required.
NOTE: The “Half Speed” selection is not available in the “Best” print quality mode.

SECTION 3 OPERATING THE PRINTER

- **My Print Settings** – Allows you to save or recall your custom Driver settings for various jobs. When you save or replace a “My Printer Settings” selection, all settings within the General, Layout and Color tabs are saved.

Layout Tab

Layout allows you change how the document prints without changing the original document.

- **Resizing**

- **Original Size** – no changes
- **Custom Resize** - lets you resize the original as a % of normal size. The printer will print the document in the size you selected regardless of the size of the paper selected.
- **Print on:** Lets you specify the size of paper that you want to print on regardless of the size of the original document.
Checking “**Scale to Fit**” automatically resizes the document to fit on the new page size.

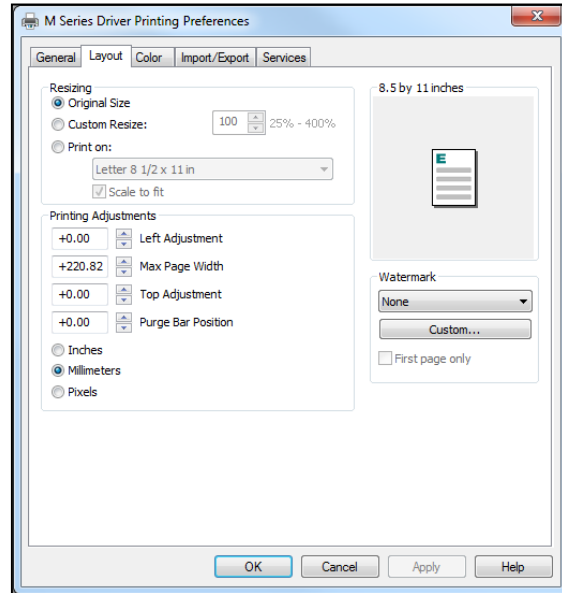

- **Printing Adjustments** – Allows you to make minor changes to the print position and print area, in relationship to the media feed direction.

NOTE: The values entered, in the following adjustments, do NOT override the values set in the Toolbox (User Interface and Service Menus - Printer Control Config). Instead, the values entered are added to or subtracted from the values set in the Toolbox. The range values (min and max), provided below, assume that the Toolbox values for “tof_adjustment” and “left_adjustment” are set to zero (0) and the Purge Bar Position in the Toolbox, User Interface screen, is set to zero (0). Exceeding these min or max values may cause the printer to print nothing (feed the media blank).

- **Left Adjustment** – Lets you shift the printed image left or right.
Range: -2.98mm left to +200.02mm right. Default = Zero (0)
negative value = shift right (towards operator side)
positive value = shift left (towards non-operator side)
Zero (0) = left edge of media, if Media Registration Side Guide is set to “inner position”.
- **Max Page Width** – Lets you limit how wide the actual print area will be. This feature can be used to “cut-off” the right-side (operator side) of an image, at a set position.
Range: +0.5mm to +220.82mm. Default = 220.82 (full print width)
- **Top Adjustment** - moves the image up or down on the media.
Range: -4.95mm up to + 200.02mm down. Default = Zero (0)
negative value = shift up (towards leading edge)
positive value = shift down (towards trailing edge)
Zero (0) = leading edge of media.
- **Purge Bar Position*** – This feature allows you to adjust the purge bar location, to account for the extra length needed to reach the actual gap between pieces.
Range: -53.75mm up to +200.02mm down. Default = 0
negative value = shift up (purge sooner)
positive value = shift down (purge later)
During normal operation, the printhead spits a small amount of ink into the gap between pieces, to keep the nozzles clear and hydrated. For irregular-shaped pieces (*like an open envelope flap*), the

Paperpath Entry sensor may “see” the trailing edge too soon, causing the printer to purge (spray a line of ink) onto the flap.

Tip: Optimally, this value should be set so the purge bar is positioned about 3 mm past the trailing edge of the media.

NOTE: The value set should not exceed the physical gap that the “Paperpath Entry Sensor” sees between pieces, minus at least 5 mm. Setting this value too large may cause blank (unprinted) pieces to be fed, purge bar printing on leading edge of next piece, and or “false”

“**PAPERPATH_FEED_TIMEOUT**” conditions (with media stopping inside the print engine).

* See also “**Purge Bar Position**” in the **Toolbox Features** section. Values are cumulative.

- **Units Selection** – Printing Adjustment values can now be displayed in Inches, Millimeters or Pixels. Select between: Inches, Millimeters, or Pixels

NOTE: Values will automatically be converted when units selection is switched. However, you may find that the converted values are rounded up or rounded down.

See “**Printing Adjustments Quick Reference Sheet**”, in “**Appendix C**”, for additional details.

- **Watermark** – Prints background text onto the media along with the original image. A few selections (SAMPLE, Draft, COPY, and Confidential) are provided.
 - **First page only** – When a watermark is selected, the “First page only” option is available. Selecting this option prints the watermark on the first page, but not subsequent pages. Un-checking this option prints the watermark on all pages.
 - **Custom** – This button lets you create a new watermark or edit an existing watermark, including font selection, color, size, and printing angle.

NOTE: “**My Print Settings**” was removed from the Layout tab, but it can still be found on the “General” tab. When you save or replace a “My Printer Settings” selection, all settings within the General, Layout and Color tabs are saved.

Color Tab

The **Color Tab** features allow the operator to make global color adjustments to the output of the printer.

The following controls (sliders) are available:

- Color Tone
- Brightness
- Saturation
- C (Cyan)
- M (Magenta)
- Y (Yellow)
- K (Black)

Use the “Defaults” button to reset all selections back to zero.

NOTE: Example Image “Original” and “Adjusted” views are provided for demonstration only. They will not reflect the actual printed output. Some experimentation (changing settings and performing test prints)

will be needed to obtain the desired printed output. The adjustments made do not make any changes to the original artwork/file, but the driver settings can be saved using “My Printer Settings”, located under the General tab.

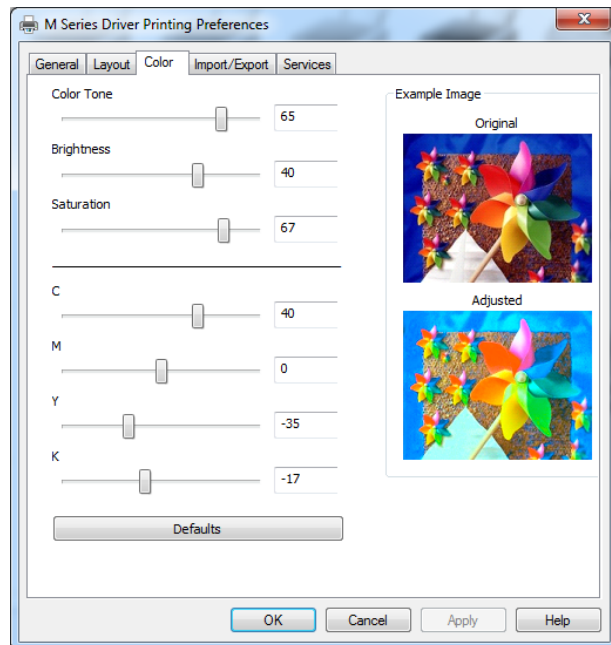

SECTION 3 OPERATING THE PRINTER

Import/Export Tab

Import/Export is used to preserve any custom Media Sizes, Watermarks and Print Settings, you may have added/created for various jobs.

- **Watermarks** – select to export/import
- **Media Sizes** – select to export/import
- **Print Settings** – select to export/import
- **Export** – Use to save your selected, custom settings to a “holding file (*.ini)” before uninstalling/re-installing/updating the M-Series Driver.
- **Import** – Used to import your selected, custom settings, from a previously saved “holding file” (*.ini), after the M-Series Driver is re-installed or updated.

IMPORTANT!

BEFORE REMOVING/REPLACING/UPDATING THE M-SERIES DRIVER, USE THIS FEATURE TO EXPORT ANY CUSTOM SETTINGS YOU HAVE ADDED/CREATED.

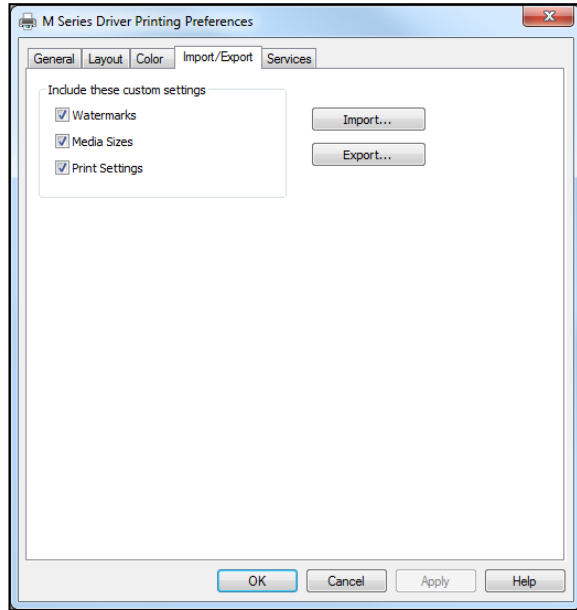

Services Tab

NOTE: The security rights/settings, on some computer systems, may prevent you from accessing the features on the “Services Tab”. These features can also be accessed via the Toolbox utility.

The Services Tab features allow you to:

- **Print Configuration Page** – Prints out the current printer configuration including firmware version, supplies status/serial numbers. Also displays NVM and VARS settings.
- **Print Colorbar Page** – Prints seven solid blocks/bars of color to show how well the Printhead is mixing colors and printing.
- **Print Diagnostic Page** – Prints out printer information such as Device serial number, Firmware version, Internal memory, page counts, Network Settings and Even Log.
- **Quick Clean Printhead** – Circulates ink, purges nozzles, wipes and cleans the surface of the printhead nozzles.
- **Normal Clean Printhead** – Provides a higher level of nozzle cleaning than “Quick Clean”.
- **Full Clean Printhead** – Provides a higher level of nozzle cleaning than “Normal Clean”.
- **Wipe Printhead** – Wipes excess ink from the surface of the printhead nozzles. No ink is ejected in this process.

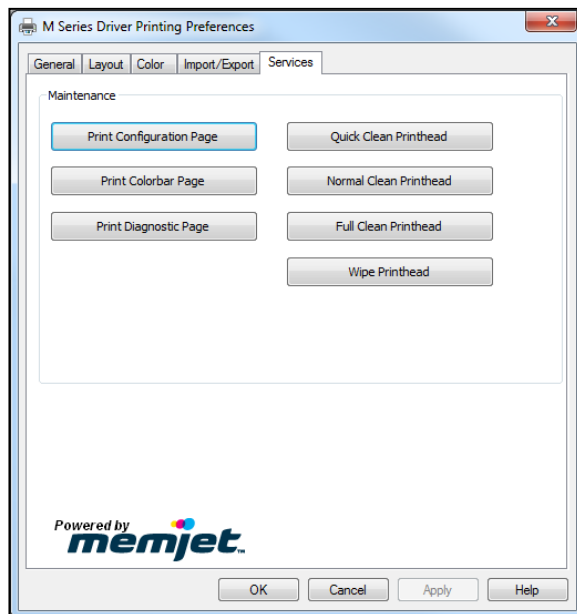

See “Maintenance Buttons”, in the Toolbox Features section, for additional information and tips.

Toolbox Features

Valid for printers with Firmware version R15 20180323 installed.

Once the Printer Driver is installed, you can access the **Printer Toolbox**. You can check Printer status, monitor ink usage, perform diagnostic checks, print reports, and run maintenance tasks on the Printer from your computer. **The Toolbox works with both conventional and touchscreen computer screens.**

To open the Toolbox:

Open **Start Menu**, then click on **Toolbox**. **NOTE: Conventional Screens:** Use your cursor.

Touchscreens: Tap buttons or selections or use your cursor.

NOTE: If you have more than one copy of the M-Series Driver on your computer system, when you launch the Toolbox, you will be presented with a list of “Available Printers” (similar to center image shown below). Select the desired printer from this list, to open the Toolbox for that printer.

When **System Status** window opens:

[A] System Status Indicator and Drop-Down Menu Options (*at top of screen*).

[B] Check Printer Status of both Printers (*across middle of screen*).

[C] Four often-used control buttons (*at bottom of screen*).

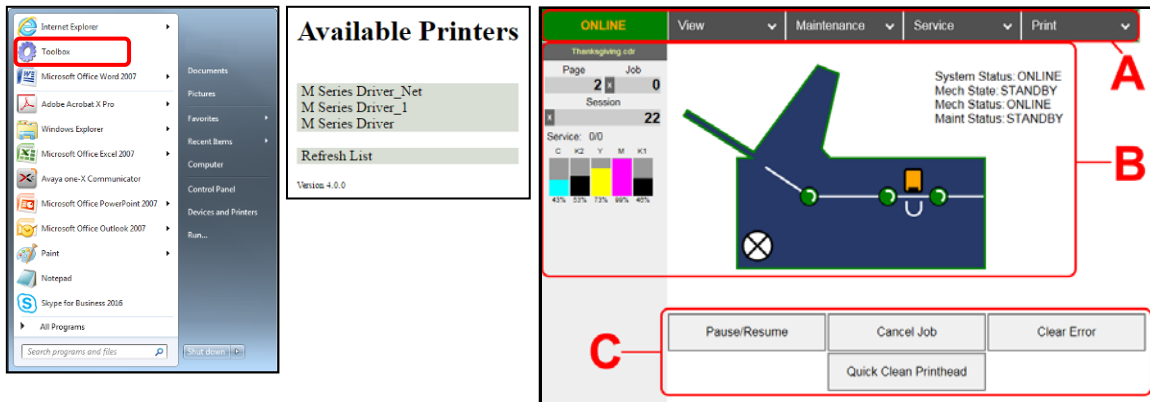

Drop-Down Menu Options



There are four **Drop-Down Menus**:

View, Maintenance, Service and Print. The drop-down menus are available on every Toolbox screen allowing you to toggle between menus and select different Printer features and functions.

View Drop-Down Menu

The **View** drop-down gives you four choices: **System Status, User Interface, Ink Usage and Service Menus.**

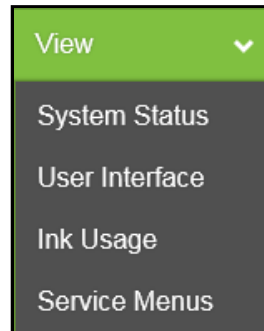

SECTION 3 OPERATING THE PRINTER

System Status

This screen opens when you access the Toolbox. It provides information about the Printer. Select “**View**”, then “**System Status**” to return to this screen.

Left side:

Status Indicator shows Printer activity as **ONLINE**, **ERROR**, **MAINTENANCE**, **PRINTING** or **PAUSED**. The gray box (*below Status Indicator*) shows the name of the job being processed.

Page shows the page count for a given job.

Job shows number of jobs printed (*resettable*), **Session** shows the total number of pages printed by the Printer (*resettable*) over the length of a Session (*shift, day, week, etc.*).

Service shows the number of pages printed (*first number*) up to the next mid-job servicing (*second number*). The second number can be set in **Mid-Job Servicing** on the **User Interface** screen.

Ink Levels displays percentage of ink remaining in each of the Ink Tanks in the Printer.

Date and Time are configured and set using **Date and Time** on the **System Settings** screen.

Printer Icon: Shows status of the Media Sensors located in the media feed path of the Printer. Also shows status of Ink Valves, Service Station, and Printhead. These can alert the operator to the type and location of a problem.

Tapping or rolling over any of the status icons with your cursor pops up a description of that icon.

Right side:

Shows basic operating information about the Printer.

CONTROL BUTTONS (*located along bottom of the screen*): **Pause/Resume**, **Cancel a Job**, **Clear Error**, and **Quick Clean Printhead**. Provide quick access to often-used functions.

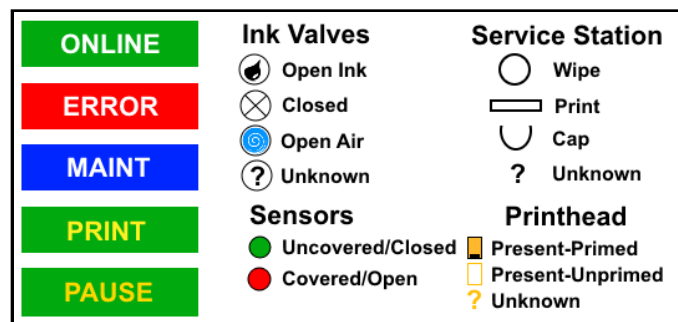
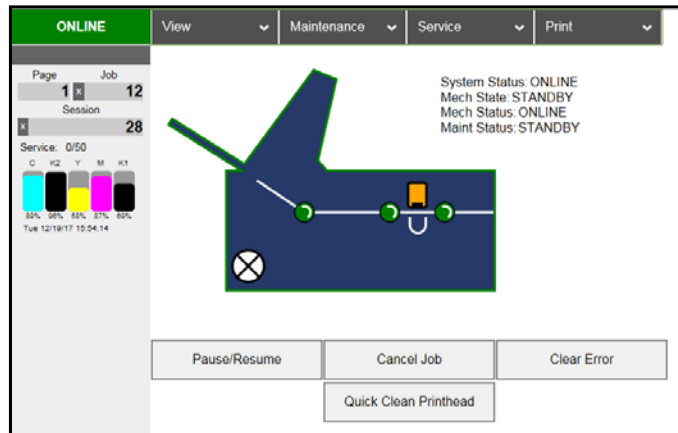

User Interface

SETUP Settings – Select “**View**”, then “**User Interface**” to open.

You can adjust automated service and cleaning intervals, adjust the feed mode, manually set the purge bar location and disable/enable items that may help to detect a paper jam/misfeed or eliminate false detection.

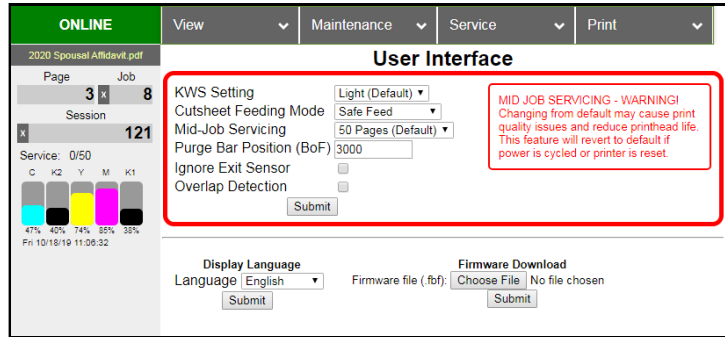

- **KWS Setting** – (*Keep Wet Spitting*) Incorporates an algorithm to periodically fire all printhead nozzles, to keep all nozzles wet, thereby reducing nozzle dehydration/clogging and print quality issues. In general, the dots produced on the media by this nozzle firing algorithm are hardly noticeable. However, in some cases the dots produced are not acceptable for the application and the user may wish to turn this feature off.
 - **None** - Intrapage spitting is turned off. KWS dots are not sprayed onto media.
WARNING: Selecting “None” will increase chances for nozzle clogging and print quality issues.
 - **Light (Default)** - Intrapage spitting frequency is set to the "default" level. KWS dots are sprayed onto media to help reduce nozzle clogging and print quality issues.
 - **Heavy** - Intrapage spitting frequency is increased. An increased number of KWS dots are sprayed onto media to further reduced nozzle clogging and print quality issues.

NOTE: KWS choices are limited by the “Mid-Job Servicing” selection.

- Mid-Job Servicing set to 50 or 100 pages = KWS selections: None, Light, Heavy
- Mid-Job Servicing set to 250, 500 or 1000 pages = KWS sections: Light or Heavy
- Mid-Job Servicing is set to 2500 pages = KWS will automatically be set to Heavy

- **Cutsheet Feeding Mode** – Permits you to change how the Printer feeds media, depending on the type of job you are running. By default, this value is set to “Safe Feed”.
 - **Safe Feed** – Larger gap between pieces provides slower throughput, but less chance for blanks (unprinted pieces) to be fed.
 - **Max Throughput** – Smaller gap between pieces provides higher throughput but expect blanks (unprinted pieces) to be fed at end of job and whenever there is a pause in job.
- **Mid-Job Servicing** – Allows the user to adjust the frequency of printhead cleaning (maintenance) during a print job. The values have been changed to page-based frequency control, which is more intuitive than previous versions.
The following choices are available: 50 (default)*, 100, 250, 500, 1000 or 2500 pages.

***Use 50 Pages (Default) setting only with media at least letter-sized or A4 length or longer.**

CAUTION: Changing the setting from “50 pages (default)” may increase print quality issues and reduce printhead life. The selection you make will also affect the KWS choices. See “KWS Setting”.

NOTE: This setting does not have any effect on the automatic maintenance tasks that are performed at start and end of job or anytime the printer is interrupted (paused, out of paper, paper jam, etc.).

SECTION 3 OPERATING THE PRINTER

- **Purge Bar Position (BoF)*** – During normal operation, the Printhead spits (purges) a small amount of ink, into the gap between pieces. This is done to keep the nozzles clear and hydrated. The “Purge Bar Position” feature allows the operator to manually adjust the location where the “Purge Bar” (nozzle purge) occurs. This feature is particularly useful when feeding irregular shaped media.

1000 = 1 mm. By default, this value is normally set to 3000 (3 mm).

Example: When feeding envelopes with an open, v-shaped flap (flap trailing), the Paperpath Entry Sensor will “see” the trailing edge of the media too soon, causing the “purge bar” to print onto the trailing edge of the open flap. In this case the “Purge Bar Position” value should be increased by the distance measured from the purge bar to the end of flap, plus 3000 (3 mm).

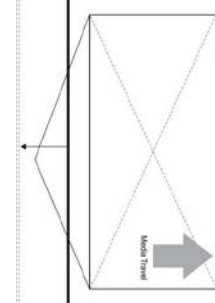

Tip: If you notice excessive ink accumulation on the Print Platen, it is recommended that you contact your service support representative and ask them to set the “interpage_freq” feature, located in the Toolbox Service Menus, to a higher value. Default = 1 Page (purge is preformed between each page). Clean the platen, then test thoroughly to see if this change produces more acceptable results.

CAUTION: Setting the “interpage_freq” feature to a higher value may reduce ink accumulation on the print platen, but it may also increase nozzle dehydration (clogging).

* See also “Purge Bar Position” in the “Printer Driver Properties” section. Values are cumulative.

- **Ignore Exit Sensor** – Disables the detection of a “paper jam” under certain conditions. Allows use of media that is non-reflective to the Paperpath Exit sensor. When this feature is NOT selected, non-reflective areas, on the underside of the media, may cause a false “paper jam” condition. The Toolbox will display “Paperpath_Paperjam”. After you select this feature and click on Submit, you will see the “Paperpath Exit” condition, shown in the Toolbox, change to “Exit: Disabled”.
NOTICE: By selecting “Ignore Exit Sensor” you are reducing the printer’s ability to detect a media feed issue. Therefore, printer transport may continue to run when a paper jam occurs. Please try cleaning sensors, as outlined in the user’s guide, before selecting this feature. This feature will not solve issues caused by media transport (slipping, hesitating) or a damaged Exit Sensor.
- **Overlap Detection** - Uses the Paperpath Entry sensor to monitor changes in media density.

IMPORTANT: Overlap Detection is set to off (unchecked) by default. Please be sure Overlap Detection is off (unchecked) when feeding envelopes or media that contains variations in media thickness/density. This feature should only be used when feeding media that is of a single thickness/density (like single sheets of paper).

If this feature is enabled (box checked) and the media density changes significantly, the printer assumes this is caused by overlapping media. In this case the printer will stop, and the toolbox will initially display “PAPERPATH_PAGE_SEQUENCE” and the PAPER key will flash. Then the Toolbox display may change to “PAPERPATH_PAPERJAM”.

After the paper path has been cleared, Press the Pause/Resume button, in the Toolbox or on the Printer’s Control Panel, to “Resume” printing. The current page will be automatically reprinted, and the remaining job will continue printing.

PLEASE BE SURE TO HIT "SUBMIT" AFTER CHANGING THESE SETTINGS

Display Language – Selects the language the Toolbox information will be displayed in.

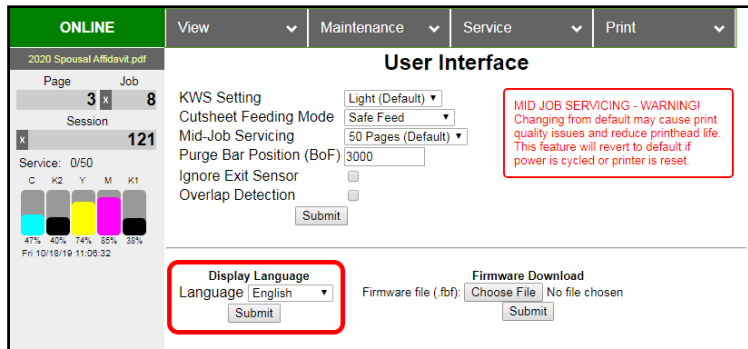

PLEASE BE SURE TO HIT "SUBMIT" AFTER CHANGING THIS SETTINGS

Firmware Download – This feature is used to update the firmware in the printer.

WARNING: This process should only be performed by a qualified support representative. In some cases, firmware must be loaded using the “Firmware Migration Tool”. If this process is not performed properly, it can render the printer inoperable.

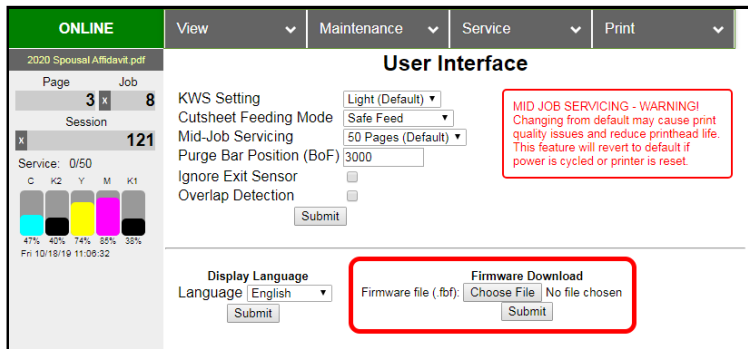

Ink Usage Menu

- **Ink Usage** -- Selecting “View”, then “Ink Usage” to open.

- **Printed Ink (µL)** - These values are provided for the purpose of estimating the amount of ink usage for a particular print job.
NOTE: Printed Ink values are provided in micro-liters (µL). Each Ink Tank holds 250 ml (250,000 µL) of ink, when full.

Printed Ink (µL)					Job	Pages Printed	Quality	Media Type	Media Size (inches)	Estimated Page Cost	Estimated Job Cost
Cyan	Black 2	Yellow	Magenta	Black 1	1:Color Bars	1	Normal	Default	8.53 x 11.14	0.201	0.201

Refresh
Upload Table

Ink Estimation Mode
Mode: Off
Submit

Job Cost Settings
Tank Cost: 250
Printhead Cost: 600
Media Size: inches
Submit

Enabling Ink Estimation Mode will inhibit printing!

- **Job** – displays name of print job, as provided by software/driver.
- **Pages Printed** – displays number of pages that have been printed for this job.
- **Quality** – displays the print quality (normal or best) selected for this job, as set by the software/driver.
- **Media Type** – displays the media type selected for this job, as set by the software/driver.
- **Media Size** – displays the dimensions (W x H) of the media, as provided by the software/driver. Values set as millimeters (mm) or inches, set by the operator under “Job Cost Settings”.

Tip: The values displayed under “Printed Ink” and “Pages Printed” can be used to estimate how many pages can be printed before each Ink Tank is empty, assuming all Tanks are full, and job is constant. For Example: Using the information displayed in the image provided above, the “1:Color Bars” job used an average of 38 µL, of Cyan ink, to print one page. Therefore, it can be calculated that a full Cyan Ink Tank should be empty after printing approximately 6,579 pages (250,000/38= 6,579) of this job.

Estimated Page Cost and Estimated Job Cost – Provides estimated page and job costs. Please verify the cost values entered under “Job Cost Settings”.

Estimated Page Cost	Estimated Job Cost
0.201	0.201

NOTICE: Estimated Page Costs and Estimated Job Costs are provided for “estimation” purposes only. No guarantee of accuracy is expressed or implied. To improve estimation accuracy, it is recommended to print at least 999 pages.

The calculator uses the following items to estimate the page and job costs.

- Print job info (Pages Printed, Print Quality, Media Type, Media Size).
- Number of nozzle ejections (Printed Ink) and width of the printhead area being used.
Why is the width of printhead area being used important?
This information is used to amortize the cost of the printhead. An image printed within a smaller printhead area (example: 1” horizontal x 2” vertical block) will use the same nozzles more frequently, as compared to printing the same image with a wider printhead area (2” horizontal x 1” vertical block). Nozzles used more often will begin to fail first. Therefore, the number of pieces a printhead is estimated to be able to print, before nozzle “end of life” is reached, can vary based on the vertical length of the image being printed on each page. Unfortunately, there is no way for the calculator to obtain the actual width and length of an image being printed, so the Media Size (Width x Length) is used, as a factor, in this estimation process.
NOTE: Memjet estimates nozzle life at ~125,000* linear inches of continuous printing.
*This is NOT an expression of Warranty. Individual results will vary.
- User provided information (Job Cost Settings) about printhead and ink costs.
Note: Enter the cost of a single Ink Tank only (estimator internally multiplies by 5).

- **Job Cost Settings** – The operator should enter the average amount paid for a *single* Ink Tank (estimator internally multiplies this figure by 5) and the amount paid for the printhead, then press “**Submit**”. These values are then used to calculate the “Estimated Page Cost” and “Estimated Job Cost”.

- **Tank Cost** - enter the average amount paid for a single Ink Tank (estimator internally multiplies this figure by 5)
- **Printhead Cost** – enter the amount paid for the printhead.
- **Media Size** – Select how you want the media size displayed (inches or mm).

NOTE: The values entered for “Tank Cost” and “Printhead Cost” will remain until someone changes them. However, the Ink Estimation Mode will default to “Off” and the Media Size will default to “mm” whenever power is cycled.

- **Upload Table** – Creates and opens a linkable tabular data file using programs such as Microsoft Excel (default is Excel).

Ink Estimation Mode – Provides a tool to predetermine how much ink a given job may use and provides estimate page and job costs, prior to printing.

- After enabling the Ink Estimation Mode, send the job to the Printer. The job will be accepted and processed but will not print. Once the printer has completed accepting and processing the job, click on the “**Refresh**” button to display the estimated amount of ink (by color) that the job used and the estimated page and job costs.

NOTE: The estimating process will take as long as the job would take to process and print (*i.e., if the job would take 1 hour to process and print, the estimate will take 1 hour to display.*)

Mode Selections:

- **Off** - Use this choice when you want to print jobs onto media.
- **Continuous** - Use this selection when you want to estimate more than one job in a row. Stays in Ink Estimation Mode until selection is changed and submitted or until printer power is cycled. Don’t forget to set this mode back to “Off” and press submit when done.
- **Single Pass** - The Ink Estimation Mode is automatically set to “Off” after a single job is sent to the printer. This selection was added to help prevent the common mistake of, not setting this feature back to “off” after you are finished using the Ink Estimation Mode.

Click on “**Submit**” to activate your selection.

Troubleshooting Tips: If printer accepts job but will not feed or print and no error message is displayed, check to be sure the “**Ink Estimation Mode**” is set to “off”.

If not, set it to “off” and press **Submit**. Then resend job.

If “**Ink Estimation Mode**” is displayed along the left side of the Toolbox under the Ink Tank indicators, then the “**Ink Estimation Mode**” is enabled (on).

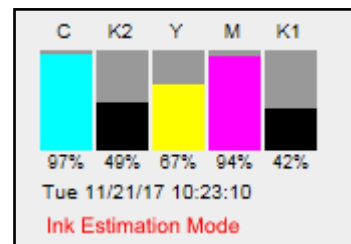

WARNING!

Enabling the “**Ink Estimation Mode**” disables all printhead and ink system maintenance routines, while in this mode. Once you are finished using this feature, please be sure to turn “**Ink Estimation Mode**” **OFF** and press “**Submit**”, so the printer can perform maintenance. If this rule is not followed, poor print quality and reduced printhead life may result.

Service Menus

Select “**View**”, then “**Service Menus**” to open.

Diagnostics button. Click to check the status of the Printer.

(See *Diagnostics below.*)

System Settings button. Click to view, enter, or change settings to connect Printer to your network. Also set and configure Printer Date and Time.

(See *Network Configuration.*)

Scan Sensors button. Provides status and a log on Sensors located throughout the Printer. (See *Scan Sensors below.*)

Service Menus, Password: Entering the **Service Menu password** provides access to more advanced Printer control and maintenance menus (*see below.*)

The screenshot shows a web interface with a green header labeled "ONLINE". Below the header are three buttons: "Diagnostics", "System Settings", and "Scan Sensors". Underneath these buttons is a section titled "Service Menus" which contains a "Password" input field and a "Submit" button.

Advanced Service Menus, Password: *For authorized personnel only.*

Provides a qualified support representative, with access to advanced printer control and troubleshooting menus.

A password is required to open the following “**Service Menus**” features.

- **Printer Control Config**
- **Commands Help**
- **Exit Service Menu**

WARNING!

Service Menu items should only be accessed/changed by a qualified support representative. Improper changes to the “**Printer Control Config**” settings can have a negative impact on printer operation. Running “**Commands Help**” features, without knowledge of what they are used for, may cause damage to the system.

The screenshot shows a web interface with a green header labeled "ONLINE". Below the header are three buttons: "Diagnostics", "System Settings", and "Scan Sensors". Underneath these buttons is a section titled "Service Menus" which contains three buttons: "Printer Control Config", "Commands Help", and "Exit Service Menus".

SECTION 3 OPERATING THE PRINTER

System Settings

Set up a network connection for the Printer. Also set and configure Printer Date and Time.

Note: To access and change these printer parameters, you must initially install the printer Driver via USB and connect to the printer via USB. See “Install the Printer Software (Driver & Toolbox)” and “Connecting the Printer via Network (Ethernet Port)”, located in the Operators Guide, for detailed instructions.

Tips: The information shown on this page is just an example. You must use settings that are compatible with your network and settings that are not in direct conflict with other devices on the network. Check with your IT support person for help with the following settings. Be sure to click on “**Submit**” after entering new information. We strongly suggest using a “Static” IP address.

The screenshot shows the 'System Settings' page. It is divided into two main sections: 'Network Settings' and 'Date and Time'.
Network Settings:
Printer Name: MyPrinter1
Domain Name: ABCName.com
dhcp:
bootp:
autoip:
ip_address: 192.168.254.119
subnet_mask: 255.255.255.0
def_gateway: 192.168.254.254
wins_server: 192.168.254.11
A 'Submit' button is located at the bottom of this section.
Date and Time:
Date and Time: 14/11/17 07:31
A 'Submit' button is located below the date and time field.
24 Hour:
Date Format: mm/dd/yy (dropdown menu)
A 'Submit' button is located below the date format field.

- **Network Settings.** Permits you (or your IT person) to view, enter or change settings to connect the Printer to your network:
 - **Printer Name** – Displays the “default” printer name. A new name can be entered, if desired/required.
 - **Domain Name** – Enter the name of the Network Domain, if required.
 - **dhcp** – Uncheck if using a “Static” (manually entered) IP address. Select if using dhcp. Dynamic Host Configuration Protocol (DHCP) is a network protocol that enables a server to automatically assign an IP address to a device from a defined range of numbers configured for a given network.
 - **bootp** – Uncheck if using a “Static” (manually entered) IP address. Select if using bootp. The Bootstrap Protocol (BOOTP) is a computer networking protocol used in Internet Protocol networks to automatically assign an IP address to network devices from a configuration server.
 - **autoip** – Uncheck if using a “Static (manually entered) IP address. Select if using autoip. “Autoip” is a module that enables the automatic assignment of an IP address to a device on startup.
 - **ip_address** – Enter the “Static” Internet Protocol (IP) Address that you would like this printer to use. **Note:** If “dhcp, bootp, or autoip” are selected, and the network is configured to use any of these features, the IP Address will automatically appear here (address automatically assigned/re-assigned by network).
Tip: We strongly suggest using a “Static” IP address. If the network reassigns a new IP Address, after you have configured the printer driver to use a previous IP Address, you will lose communication with the printer until you manually change the IP Address in the driver to match the printer’s new IP Address.
 - **subnet_mask** – Enter the subnet mask address, if required.
 - **def_gateway** – Enter the def gateway address, if required.
 - **wins_server** – Enter the wins server address, if required.
 - **duplex address** – Enter the network address for the “Duplex Unit” (MACH 5DX).

The screenshot shows the 'System Settings' page, specifically the 'Network Settings' section. The settings are:
Printer Name: MyPrinter1
Domain Name: ABCName.com
dhcp:
bootp:
autoip:
ip_address: 192.168.254.119
subnet_mask: 255.255.255.0
def_gateway: 192.168.254.254
wins_server: 192.168.254.11
A 'Submit' button is located at the bottom of the section.

• **Network Connection Set Up:**

1. Printer is still connected to computer via USB cable. **To connect Printer to a network, open the Toolbox.** Select **“View”**, then select **“Service Menus”**. Click or tap **“System Settings”**.

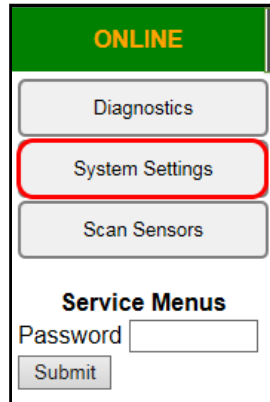

2. **“System Settings”** screen opens. Use **Network Settings** to enter correct settings for your network.

NOTE: If manually changing the **ip_address**, make sure the **“dhcp”** and **“autoip”** boxes are unchecked. (*Default is checked.*) Enter changes in the appropriate boxes.

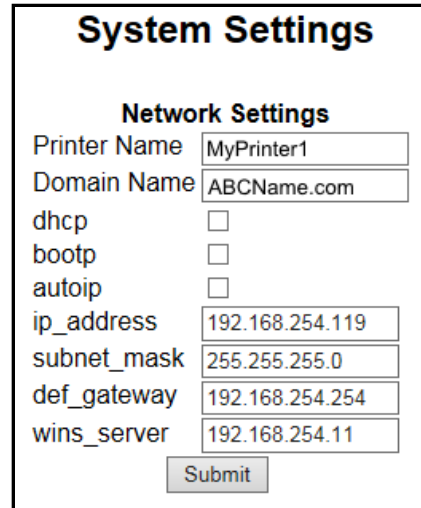

3. Click **“Submit”**.
4. Connect Ethernet cable to Network Port on Rear Panel of Printer.



- **Date and Time** – Enter or change the way the date and time will appear in the Printer Status section of the **Toolbox** screens.

Enter or change Date and Time:

1. Select **“View”**, then select **“Service Menus”**. Click or tap **“System Settings”**.
2. **“System Settings”** screen opens. Use **Date and Time options** to enter, edit, and configure the Date and Time for the Printer.
3. Click **“Submit”**.

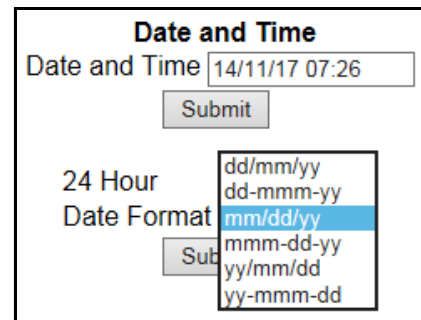
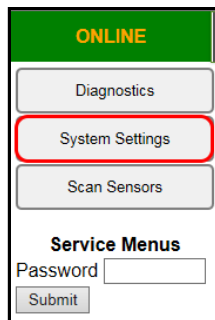

SECTION 3 OPERATING THE PRINTER

Scan Sensors

Provides status and log on Sensors located throughout both Printers.

(See chart at right.)

Tip: To capture a screenshot, click “**Stop**” button to stop scanning and “**Stop**” button to stop scanning and stop the screen from refreshing.

ONLINE		View	Maintenance	Service	Print				
Diagnostics	Stop								
System Settings									
Scan Sensors									
Service Menus									
Password									
Submit									
#	1	2	3	4	5	6	7	8	9
Entry Sensor	255	255	255	255	255	255	255	255	255
Blackmark Sensor	215	221	215	217	212	215	216	216	216
Exit Sensor	0	0	0	0	0	0	0	0	0
Clamshell Switch	Closed	Closed	Closed	Closed	Closed	Closed	Closed	Closed	Closed
Printhead Latch	Closed	Closed	Closed	Closed	Closed	Closed	Closed	Closed	Closed
Lifter Arm	1	1	1	1	1	1	1	1	1
Sled Index	0	0	0	0	0	0	0	0	0
Sled Home	0	0	0	0	0	0	0	0	0
Valve Position	Closed	Closed	Closed	Closed	Closed	Closed	Closed	Closed	Closed

SENSOR	DESCRIPTION
Entry Sensor (Paper Path Entry)	Interrupted (<i>media present</i>) = 0-60 Uninterrupted (<i>no media</i>) = 255
Blackmark Sensor	NOTE: Not applicable for this model. Blackmark Sensor's output is for printers designed to run a “continuous” web of media (<i>i.e., labels</i>).
Exit Sensor (Paper Path Exit)	Uninterrupted = 0 Interrupted (<i>blocked</i>) = 1 Tip: If media has dark colors on underside, you may experience “paper jam” conditions when there is no physical media in machine. If Exit Sensor appears to be operating normally, select “ Ignore Exit Sensor ” then click “ Submit ” in User Interface screen to bypass Exit Sensor.
Clamshell Switch	Clamshell Open = 1 Clamshell Closed = 0
Printhead Latch	Closed = 0 Open = 1
Lifter Arm	Up = 1 Down = 0
Sled Index	Cap Position = 0 Print/Wipe Positions = 1
Sled Home	False = 0 True = 1
Valve Position	Displays operating positions of Dual Pinch Valve: “OpenAir,” “OpenInk,” and “Closed”. “Unknown” will display as Valve transitions between positions. NOTE: If “Unknown” displays for more than a few seconds, it may indicate a problem.

Maintenance Menu

The printer automatically performs maintenance tasks to keep the printhead and ink system performing properly. The following buttons can be used, as needed, to provide supplemental maintenance.

CAUTION: Over-use of these features can negatively affect print quality and printer performance.

Note: The Memjet printhead contains 70,400 nozzles. Each nozzle is a fraction of the diameter of a human hair. Under normal use, it is not uncommon for a small percentage of nozzles to become clogged/dehydrated.

- **Circulate Ink** – May be used to help purge air from the lines and prime the ink system.
- **Quick Clean Printhead** – Circulates ink, purges nozzles, wipes and cleans surface of the printhead nozzles.
- **Normal Clean Printhead** – Provides a higher level of nozzle cleaning than “Quick Clean” does.
- **Full Clean Printhead** – Provides a higher level of nozzle cleaning than “Normal Clean” does.
- **Wipe Printhead** – Wipes excess ink from the surface of the printhead nozzles. No ink is ejected in this process.
Tip: If you open the clamshell before pressing this button, this feature can be used, by an experience/trained user or technician, to inspect the wiper roller. Please be sure to keep hands and loose clothing clear of all moving parts. Please be sure to properly open/close clamshell.

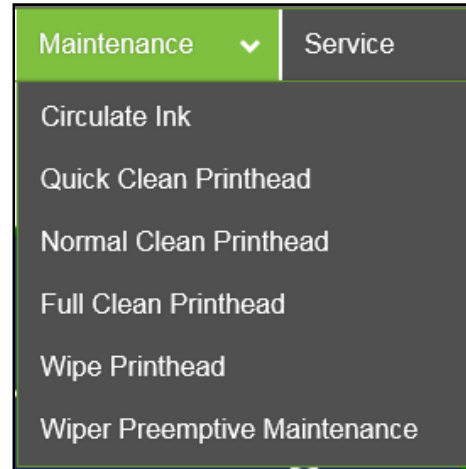

- **Wiper Preemptive Maintenance** – The “wiper preemptive maintenance” feature was added to help improve printhead nozzle cleaning and prevent damage to the wiper module, due to ink coagulation caused by extended periods of inactivity or non-use. When this button is pressed, the printer saturates the Wiper Roller, with ink, to help break-up and remove coagulated ink residue from the wiper roller and wiper module.

TIP for customers that don't print frequently: If the printer is not being used “on a regular basis” (printer sits off or idle for more than three days at a time), it is recommended that you contact your service support representative and ask them to set the “wiper_maint_cycle” feature, located in the Toolbox Service Menus, to 72 hours. This will provide automatic “wiper preventive maintenance” every 72 hours. Default = zero (off).

What occurs during the Wiper Preemptive Maintenance process?

The wiper roller is positioned underneath the printhead nozzles. The printhead ejects a regulated amount of ink, while the wiper roller is spinning slowly beneath the printhead nozzles. Coagulated ink is re-hydrated by the new ink, allowing the ink to be removed (squeezed-out) as the wiper roller rotates against the squeegee roller. It has been estimated that the amount of ink used in this process is similar to the amount of ink used during the “Full Clean Printhead” process.

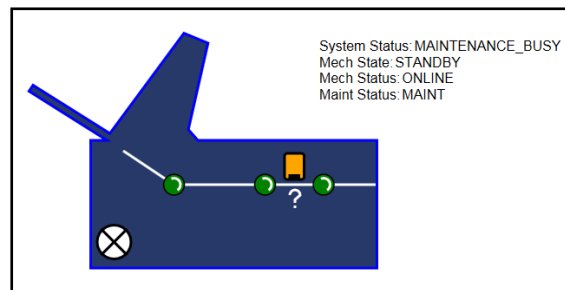

NOTE: When “wiper preemptive maintenance” is being performed, the Toolbox System Status will be displayed as “MAINT” and “MAINTENANCE_BUSY”. You will also see various icons appear in the Service Station position on the Printer icon as the Printer performs the procedure.

SECTION 3 OPERATING THE PRINTER

Tips: If using these cleaning features have no effect, or they increase print quality issues, this may be an indication that the printhead and or “wiper roller” may need to be replaced or the “Service Station” may need to be serviced. Due to the fact that a dirty/worn/damaged “wiper roller” can cause damage to a new printhead, it is recommended that the “wiper roller” be replaced whenever the printhead is replaced. Please contact your service preventative to have them perform this procedure.

Do NOT use the above features to try to reduce “scuff marks” (black lines/streaks that get deposited on the media surface) and image smudging/smearing. Using these features will normally aggravate these issues. “Scuff marks” occur when the media makes contact with the printhead. Smudging/smearing occurs when the wet image makes contact with the printhead or other areas.

The most common head to media contact areas are the high points (bows, bends, flaps) on the media and the trailing edge of the media.

Things that may help reduce scuff marks and image smudging/smearing:

- Check to be sure the “Head Media Guide” and or “PPS Spacers” are installed. See section titled “Envelope Printing Attachment Kit” in the Operators Guide for more details.
- Check to be sure the Head Media Guide, Printhead, lip of Cap (capping station) and other surfaces are clean. Clean using distilled water and a lint free cloth.
- Try feeding the media in a different orientation. Rotate piece 90, 180, 270 degrees.
- Try to use media that is flat (not warped, bowed, or bent). Be sure flaps are folded crisply.

Service Menu

WARNING! These buttons should only be used by an experienced/trained user. Improper usage can cause damage to the system. These buttons control functions that require the machine to be “out of service”, for extended periods of time, while procedures are being performed. To help reduce the chance of an accidental button press, an acknowledgement step was also added to the function of these buttons. If one of functions is selected, you will be prompted with a message asking if you are sure you want to continue.

- **Replace Ink Tanks** – Disconnects Printer communication with Ink Tanks, allowing for the safe removal or install of Ink Tanks. Press the “Replace Ink Tanks” button before removing/installing Ink Tanks. Press the “Continue” button only after verifying that the Ink Tanks have been properly installed and the Ink Tank Latches are secure.
WARNING: If the above procedure is not followed, damage to the Ink Tanks may result, rendering them useless.
- **Refresh Ink Levels** – Used to update or confirm the ink levels shown at the left side of the screen.
- **Eject Service Station** – Drives the Service Station out until it is released from the drive gears, so it can be removed for cleaning, repair, or replacement. Please refer to the “Maintenance” section, in the Operators Guide, for additional details.
- **Install Service Station** – Pulls the Service Station back into place after cleaning, repair, or replacement.
- **System Deprime** – Used to pump most of the ink back into the Ink Tanks, prior to servicing or transporting the Printer.
- **Release Printhead** – Use to remove/install the Printhead Cartridge. Pressing this button will cause the printer to partially deprime the system (evacuate ink from the printhead) and release the Printhead Latch.
- **Shutdown** – Powers-down the print-engine. Same as pressing the ON/OFF button on the printer’s control panel.
To help improve print quality and printhead life, it is recommended to always keep the printer powered-up, so, the printer can perform routine maintenance. If you need to turn the printer off, please be sure to power-down the print-engine, using the “Shutdown” button in the Toolbox or the ON/OFF button on the control panel. Wait until all the control panel buttons go out, before turning off the Main Power Switch.
- **Restart** – This new button can be used to Restart (reboot) the printer more quickly than when using the power-down or shutdown processes. Pressing the Restart button bypasses the shutdown maintenance routines, thereby reducing the overall reboot time.

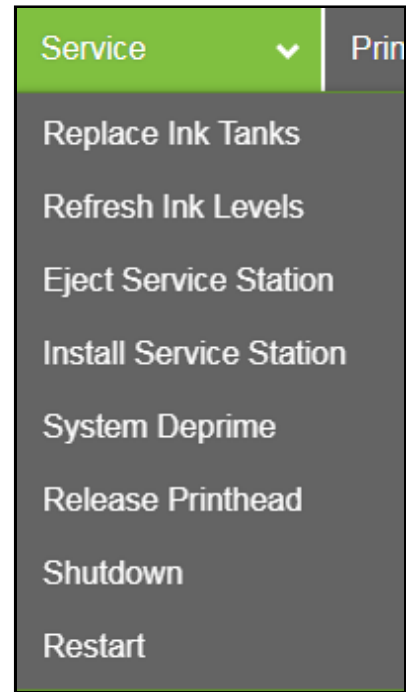

Print Menu

Print various reports and Printer tests. **Each printout displays information about the Printer.**

- **Print Setup Page** – Prints a test pattern used to align front and back sides of a page printed with “MACH 5DX” duplexing system.
NOTE: Do not use to align border-lines with page edges.
- **Print Configuration Page** – Prints out the current printer configuration including Firmware Version and supplies status/serial numbers.
- **Print Diagnostics Page** – Prints out printer information such as Device serial number, Firmware version, Internal memory, page counts, Network Settings and Event Log.
- **Print Printhead Test** – Prints small color bands, text, and patterns. Used to check the condition of the printhead nozzles. Smaller text and patterns help to show any inaccuracies in dot placement.
- **Print Ink Channels** – Prints 5 solid blocks/bars of color (1 block/bar from each Ink Tank CMYKK) to show how well the nozzles are performing, in each color channel of the Printhead.
Tip: This function can also be accessed by pressing the “**Print Ink Channels**” button, located on the top, non-operator side, of the Print Engine.
- **Print Color Bars Page** – Prints a series of 7 color bars to show how well the Printhead is mixing colors and printing.

NOTE: Load 8.5 x 11, or longer, media before performing the above printouts. Wait for the job or test print to finish before pressing any additional buttons.

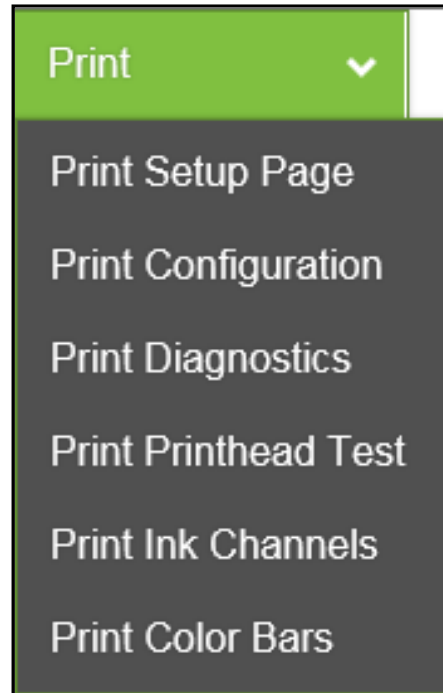

Printing

Once the printer installation and setup is complete, you are ready to start printing.

Please see the section titled “Software Setup Information” for details on how to setup the computer software to print to the printer.

If a printhead was recently installed or the printer was left powered OFF for more than a few hours, it is recommend that you perform a “Printhead Cartridge Conditioning” routine, outlined below, before you print a live job.

Printhead Cartridge Conditioning

When a printhead cartridge is installed, it is normal for some residual ink accumulation to occur in certain areas within the print engine. There may also be some color contamination between ink channels and air bubbles trapped in the printhead. These contaminants should be manually cleaned from the components and purged from the printhead. Air bubbles in the printhead will present themselves as unevenly shaped bands of missing color. Color contamination will present itself as mottled, muddy, or distorted colors. See “Print Quality Issues” for more details.

After installing a new printhead cartridge, or reinstall a used printhead cartridge, please use the following routine to condition the cartridge and system.

Note: The following process assumes you are using a printer with firmware R15 20180323 or higher installed.

1. Power-down the printer. After all the control panel lights go out, carefully open the clamshell, and inspect/clean any visible ink from the following areas.
Printhead surface. Head Guide (you may need to remove to clean behind guide). Rubber lip of capping station. **NOTE:** Residual ink will normally be deposited in these areas during the priming process, which occurs after a printhead is installed.
Once you are finished cleaning, carefully close and latch the clamshell.
2. Power-up the printer.
3. Setup and load the printer with at least ten sheets of 8.5 x 11 inkjet suitable paper.
4. Open the “**Toolbox**” utility.
5. Select the “**Maintenance**” drop down menu (located at top of Toolbox screen). Click on “**Circulate Ink**”.
While the ink is circulating, tap lightly on the ink tubes, located at the operator side of the printer, and on the printhead cartridge. This will help dislodge air bubbles, allowing them to pass through the printhead and out the non-operator side of the printhead.
NOTE: It is normal to see a small amount of air bubble accumulation in the ink tubes located at the non-operator side of the printer. This is OK.
IMPORTANT! To avoid abnormal pressure buildup in the ink system, do NOT select the “**Circulate Ink**” more than once every 15 minutes (not to exceed more than three times in one hour).
6. Select the “**Print**” drop down menu (located at top of Toolbox screen).
The “**Print**” menu will open.
7. Click on “**Print Ink Channels**”.
A page representing each individual ink channel (CMYKK) will be printed.
8. Once the “**Print Ink Channels**” page has finished printing, check the results.
If the output is not acceptable, repeat this process until you are satisfied with the output. You should notice that each time you print another page, the image quality and color will improve. It may take up to ten pages before the output is satisfactory.
NOTE: Make sure you allow the printer to completely print each page before you press the “**Print Ink Channels**” button again.
9. Now you are ready to print your job.

Section 4 – Software Setup Information

General Software Setup Info

Note: The following information assumes you have the M Series Driver version 14.2 or higher installed on computer system and firmware version 20151228 or higher installed on printer.

Do NOT exceed the Min or Max media specifications of the printer:

- **Minimum paper size** printer can feed: 3" wide x 4.13" height (length).
- **Maximum paper size** printer can support: 9.5" wide x 17" height (length).

Tip: Set the Media Registration Side Guide to accommodate your media width.

- Inner position for media measuring 3" to 8.5" in width.
- Outer position for media measuring 8.6" to 9.5" in width.

- **Maximum print area:** 8.5" wide x 17" height (length).

NOTE: The printer driver and firmware will accept up to a 30" height (length), but the Rear Media Support Guide will not support media over 17" long.

Software Setup for media that is 3" to 8.5" wide:

Select a matching "Media Size" from the pull-down list within the driver or use the "Custom Sizes" (Custom Media Size) button, within the driver, to set the paper width and height (length) to the dimensions of the media. Then set the paper size, within your software, to the same selection/dimensions set within the driver.

Examples:

8.5" x 11" document: Select "Letter" or set a Custom Media Size of 8.5" wide by 11" height (length), in software and M Series Driver. Set top, bottom, left and right margins to minimum values, or any margin you require. Set Portrait orientation in software and driver.

10 envelope (4.13" W x 9.5" L) feeding short-edge first: Select "Env. Com10 4 1/8 x 9 1/2 in – Portrait", in software and driver. Set top, bottom, left and right margins to minimum values, or any margin you require. Set Landscape orientation in software and Portrait orientation driver.

Software Setup for media that is 8.6" to 9.5" wide:

Select a matching "Media Size" from the pull-down list within the M Series Driver or use the "Custom Sizes" (Custom Media Size) button, in the driver, to set the paper width to 8.5" and the paper height (length) to the actual length of your media. Then set the paper size, within your software, to the same selection/dimensions set within the driver.

Examples:

9" x 12.75" document: Set a Custom Media Size of 9" W by 12.75" H (length) in driver and software. Set top, bottom, left and right margins to minimum values, or any margin you require. Set Portrait orientation in driver and software.

10 envelope (9.5" W x 4.13" L) feeding long-edge first: Select "Env. Com10 4 1/8 x 9 1/2 in – Landscape", in the software and driver. Set top, bottom, left and right margins to minimum values, or any margins you require. Set Landscape orientation in the software and Portrait orientation in the driver.

Adobe® Acrobat/Reader Setup Tips

In general, printing a PDF from Adobe Acrobat/Reader is straight-forward and easy. However, there are a few limitations and quirks that you should be aware of.

1. Original PDF should be designed for the piece size and orientation you plan to use.

Adobe Acrobat has some nice controls for changing orientation and adjusting the image size to fit the media size you select, but there are limits.

For example, if you plan to print an image that covers the entire area of a #10 envelope (9.5” x 4.13”), make sure the original document (PDF) was designed to print an image of this size and in the proper orientation. If the image is designed to print on a #10 envelope in landscape orientation (feeding long-edge first), the image will be limited to 8.5” in width. If you rotate this image, via Adobe, to print in the portrait orientation (feeding short-edge first), you will not be able to make the image fill the entire length (9.5”) of the envelope.

2. Copies are limited to 999.

To print more than 999 copies, duplicate your original PDF to increase the number of pages in the document. For example, if you create ten pages of the same image in the document, the number of pieces you can print in one job are increased to 9,990.

3. Possible font printing issues.

If some of the characters (fonts) are not fully printed (looks as if they fade-out), try setting Adobe to print the file as an image.

The “Print As Image” feature can be found in the Print dialog box, within Adobe Acrobat.

Click on Print and then click on the “Advanced” button.

Select “Print As Image”. Be sure to set the Adobe resolution to the highest setting (600 dpi).

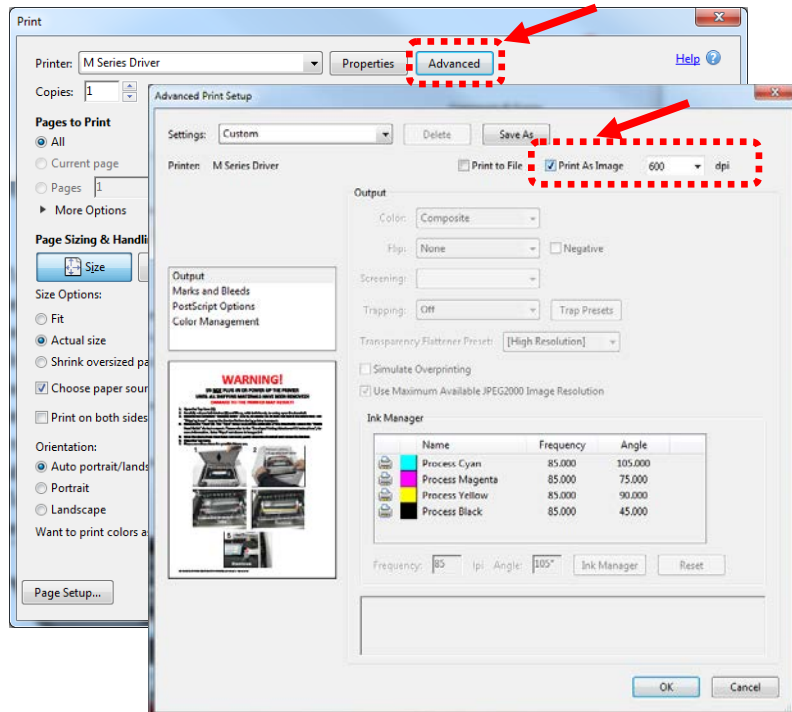
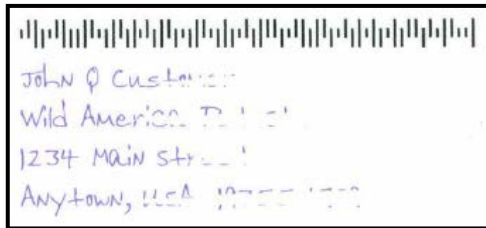

SECTION 4 SOFTWARE SETUP INFORMATION

4. If you select “Print in grayscale (black and white)”, from the Adobe print dialog box, this will cause everything to be printed in “grayscale”, even if the driver preferences are set to “color”.
5. If you select “Save ink/toner”, from the Adobe print dialog box, this will reduce the amount of ink being used. However, it will also make all images print dull (lighter).
6. If you don’t want to change the size of the original PDF (artwork), be sure to select “Actual size” from the adobe Print dialog box.
7. If you select “Auto portrait/landscape”, in the Adobe print dialog box, Adobe will automatically rotate the image to the orientation that it thinks works best and it will also center the image on the Media Size that you have selected in the driver. In some cases, using Portrait or Landscape selections may be a better option.

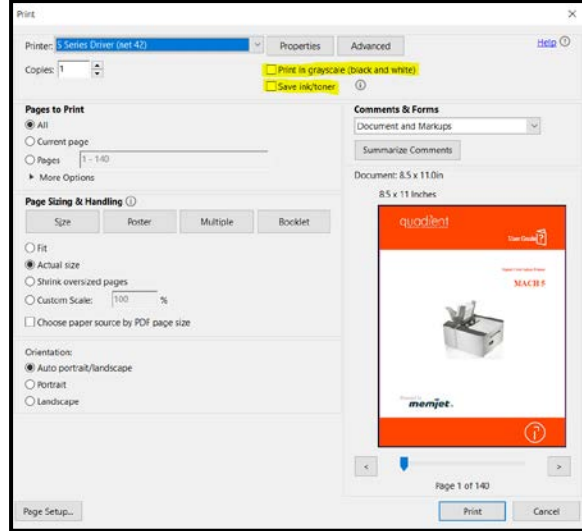

Setting Up a Job in Bulk Mailer®

Printer Driver Limitation: The developer of Bulk Mailer commonly develops printer drivers for use with their software product. However, in the case of the MACH 5 printer, they have not developed a driver for this model. Therefore, you will need to use the features within the “M Series Driver” to control print quality, orientation, etc.

The following are descriptions of how-to setup and print from Bulk Mailer 5.0 on #10 envelopes. These instructions assume you are using the M Series Driver version R14.2 or higher.

#10 Envelope, Feeding Long-Edge First (Flap First)

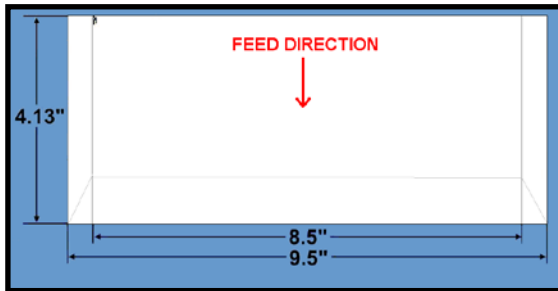

1. Open Bulk Mailer 5.
2. From the “Home” tab, select (double click) on the “mailing” of your choice.
3. Select the “Print Mail” tab (left side of screen).

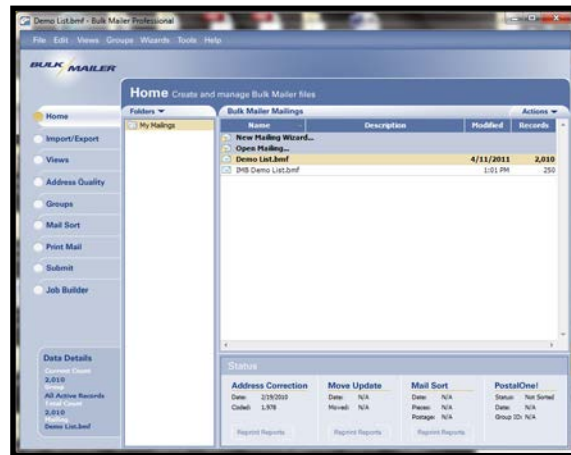

4. From the “Print Mail” screen, double-click on the “Print Mail Wizard” which will guide you through the template (layout) setup process.
5. When the Welcome screen appears click on Next.
6. The “Print Mail Template Type” window will open. Select “Envelopes – Graphical Output” and Click on Next.
7. The “Graphical Envelopes Options” window will open. Select the “M Series Driver” from the Printer pull-down list. Then select “Laser or Inkjet” Click on Next

**SECTION 4
SOFTWARE SETUP INFORMATION**

8. The “Envelope Options” window will open.
Double-click on “New Envelope/Letter Layout”

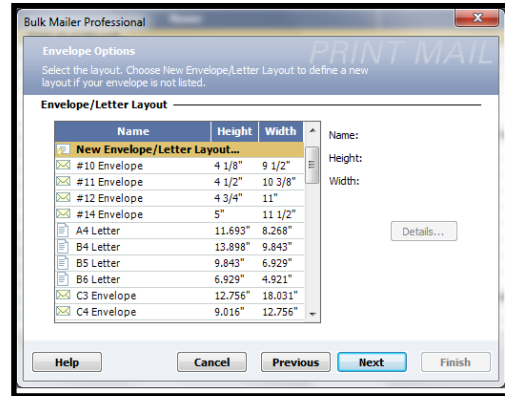

9. An envelope design window will open.
Type a name (example: Digital Color Printer #10 LEF) into the Layout Name window.
Enter these values: Page Width: 8.5 in. Page Height: 4.13 in
Click on OK and the envelope layout window will close.

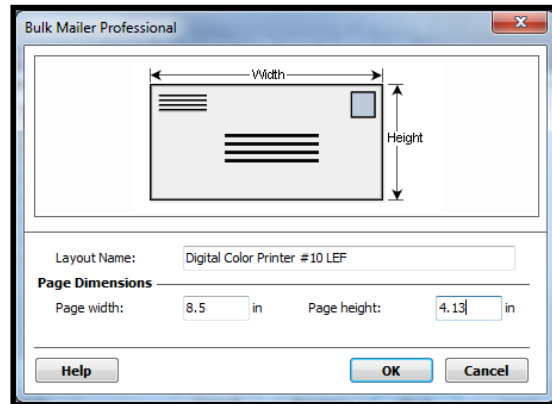

10. Click Next in the “Envelope Options” window.
11. The “Address Block Options” window will open.
Select your Address Block option (example: Add a basic address block with barcode)
Select your Barcode Type option: POSTNET or Intelligent Mail.
Click Next.
12. The “Summary” window will open.
Under Template Options select “Preview labels based on settings” and “Save settings as a new template”.
Type a name (example: Digital Color Printer #10 LEF Template) for your new template.
Then click on Finished.
13. The template will be displayed for you to edit (add, remove, position data).
Your envelope design (layout) should look similar to the one shown here.

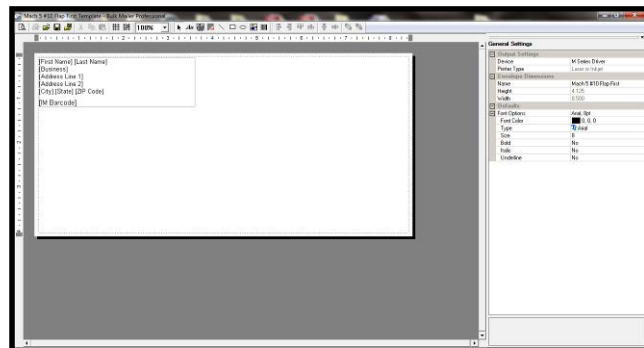

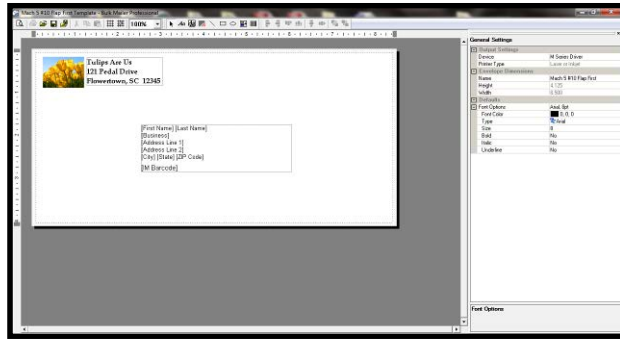

14. Add any additional items that you want printed to the “designer” screen. Drag and drop the items onto the layout, wherever you want them to be printed on the envelope. Click on Save.

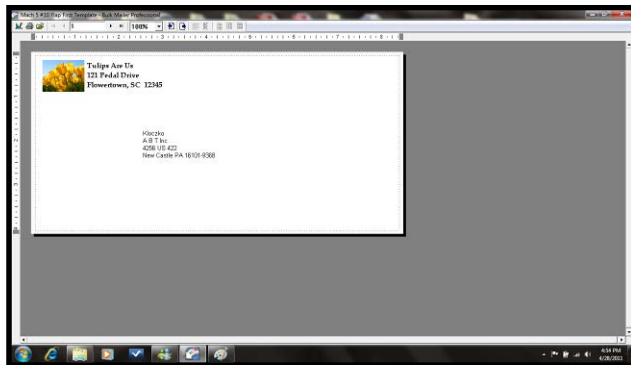

15. Click on the "Go to Preview Mode" icon , located at the upper left-hand corner of the “designer” screen. The envelope preview will be displayed.

Note: The Intelligent Mail Barcode (IMB) will not be displayed or printed unless you have “cleaned up” the mailing using the Address Quality, Address Correction (CASS) feature in Bulk Mailer. Your Bulk Mailer subscription must be current for this feature to work.



Tip: If you need to change the layout, Click on the "Go to Designer Mode" icon , to return to the "designer" screen.

16. Click on the printer icon , to open the "Mail Print Setup" dialog box. Make sure the “M Series Driver” is selected as your "Printer:".
17. From the “Mail Print Setup” window, Click on the “Advanced Settings” button. The “M Series Printer Driver Properties” window will open.



18. From the “M Series Printer Driver Properties” window, select “Env. Com10 4 1/8 x 9 1/2 in – Landscape”, as the Media Size. Then click on OK.

NOTE: As an alternative you could click on the “Custom Sizes” button then set the Width to 8.50 inches and the Height to 4.2 inches. (If you type 4.13 it will default to 4.2). Then save this as a custom media size.

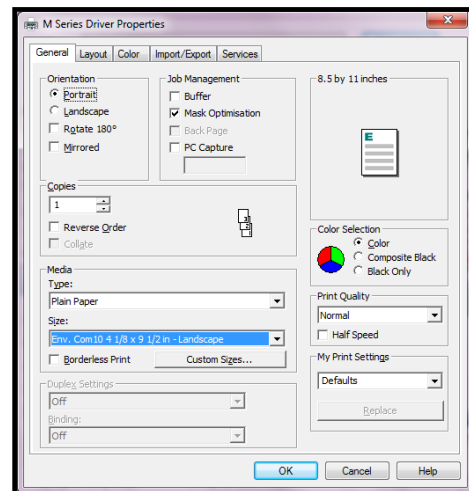

SECTION 4 SOFTWARE SETUP INFORMATION

19. Under Orientation select **Portrait**.
Select your other desired choices
Print Quality, Copies, etc.
Then Click on OK to close this window.

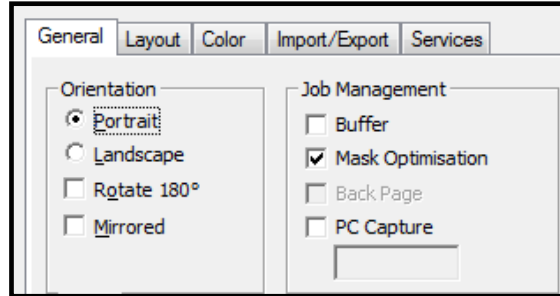

20. In the “Mail Print Setup” window select “all pages” or the range of addresses you want to send to the printer.

IMPORTANT!

If you plan to select “**Tray range**” and use the “**Pause Between**” features, to pause the printer after each Bundle/Container, please be sure to select “**Wait: for user**” and “**End print job on pause**”.

21. When ready to print, make sure the printer is ready (ON/OFF button is illuminated), then click on the "Print" button.

Note: The Intelligent Mail Barcode (IMB) will not be displayed or printed unless you have “cleaned up” the mailing list using the Address Quality, Address Correction (CASS) feature in Bulk Mailer. Your Bulk Mailer subscription must be current for this feature to work.

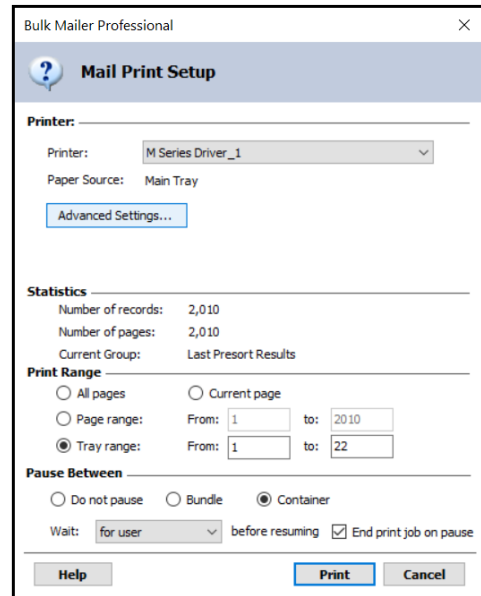

Please contact BCC Software for additional information. www.bccsoftware.com

#10 Envelope, Feeding Short-Edge First

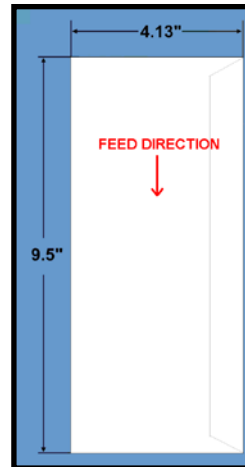

1. Open Bulk Mailer 5.
2. From the "Home" tab, select (double click) on the "mailing" of your choice.
3. Select the "Print Mail" tab (left side of screen).

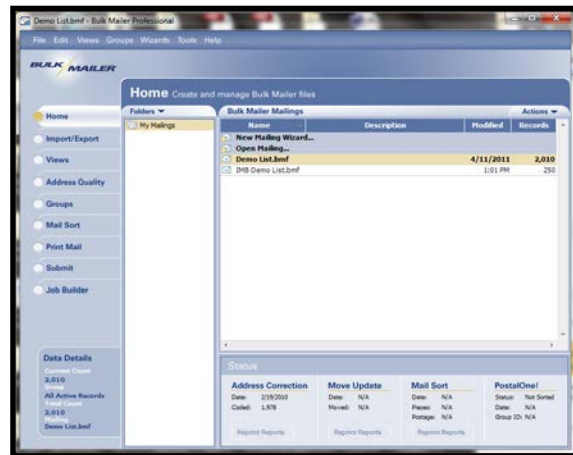

4. From the "Print Mail" screen, double-click on the "Print Mail Wizard" which will guide you through the template (layout) setup process.
5. When the Welcome screen appears click on Next.
6. The "Print Mail Template Type" window will open. Select "Envelopes – Graphical Output" and Click on Next.
7. The "Graphical Envelopes Options" window will open. Select the "M Series Driver" from the Printer pull-down list. Then select "Laser or Inkjet" Click on Next
8. The "Envelope Options" window will open. Select "#10 Envelope" (4 1/8" H x 9 1/2" W) from the list. Click Next.

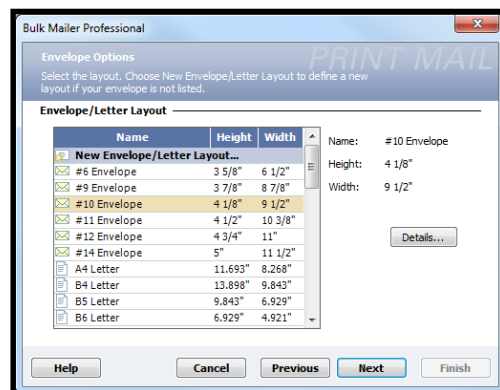

SECTION 4 SOFTWARE SETUP INFORMATION

- The “Address Block Options” window will open.
Select your Address Block option (example: Add a basic address block with barcode)
Select your Barcode Type option: POSTNET or Intelligent Mail.
Click Next.
- The “Summary” window will open.
Under Template Options select “Preview labels based on settings” and “Save settings as a new template”.
Type a name (example: Digital Color Printer #10 SEF Template) for your new template.
Then click on Finished.
- The template will be displayed for you to edit (add, remove, position data).

Your envelope design (layout) should look similar to the one shown here.

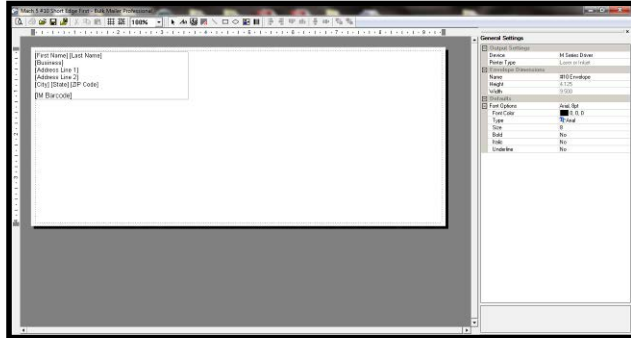

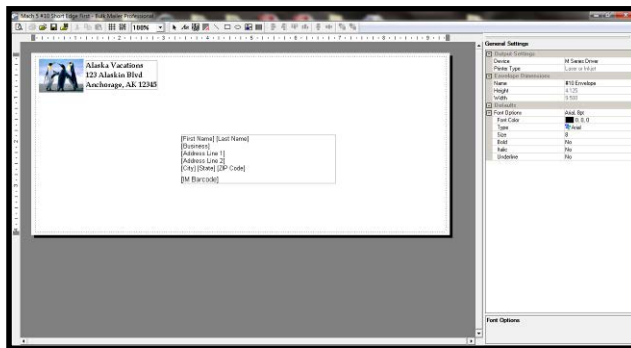

- Add any additional items that you want printed to the “designer” screen.
Drag and drop the items onto the layout, wherever you want them to be printed on the envelope.
Click on Save.

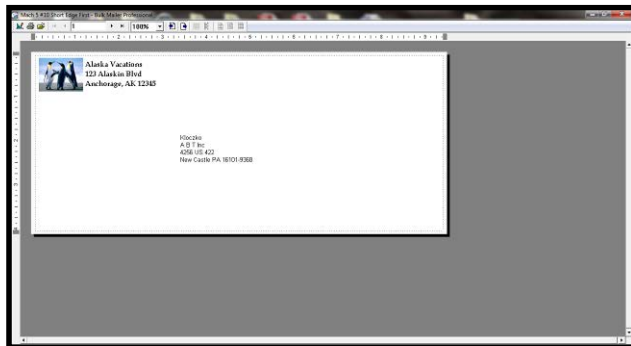

- Click on the "Go to Preview Mode" icon , located at the upper left-hand corner of the “designer” screen. The envelope preview will be displayed.

Note: The Intelligent Mail Barcode (IMB) will not be displayed or printed unless you have “cleaned up” the mailing using the Address Quality, Address Correction (CASS) feature in Bulk Mailer. Your Bulk Mailer subscription must be current for this feature to work.



Tip: If you need to change the layout, Click on the "Go to Designer Mode" icon , to return to the "designer" screen.

14. Click on the printer icon , to open the "Mail Print Setup" dialog box. Make sure the "M Series Driver" is selected as your "Printer:".

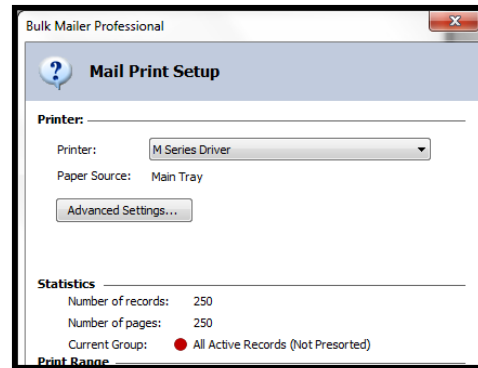

15. From the "Mail Print Setup" window, Click on the "Advanced Settings" button. The "M Series Printer Driver Properties" window will open. Under **Media Size** select "Env. Com10 4 1/8 x 9 1/2 in - Portrait". Under **Orientation** select **Landscape**. Select your other desired choices Print quality, Copies, etc. Then Click on OK to close this window.

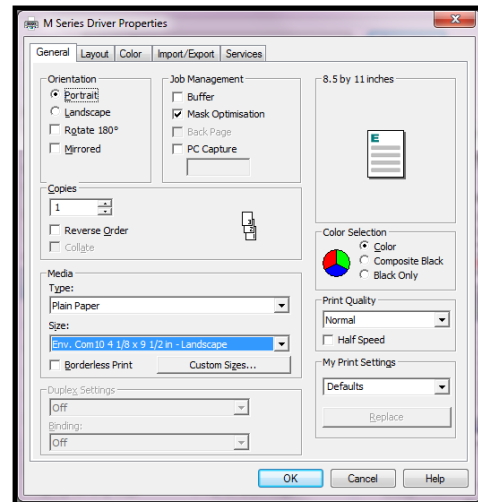

16. In the "Mail Print Setup" window select "all pages" or the range of addresses you want to send to the printer.

IMPORTANT!

If you plan to select "Tray range" and use the "Pause Between" features, to pause the printer after each Bundle/Container, please be sure to select "Wait: for user" and "End print job on pause".

17. When ready to print, make sure the printer is ready (ON/OFF button is illuminated), then click on the "Print" button.

Note: The Intelligent Mail Barcode (IMB) will not be displayed or printed unless you have "cleaned up" the mailing list using the Address Quality, Address Correction (CASS) feature in Bulk Mailer. Your Bulk Mailer subscription must be current for this feature to work.

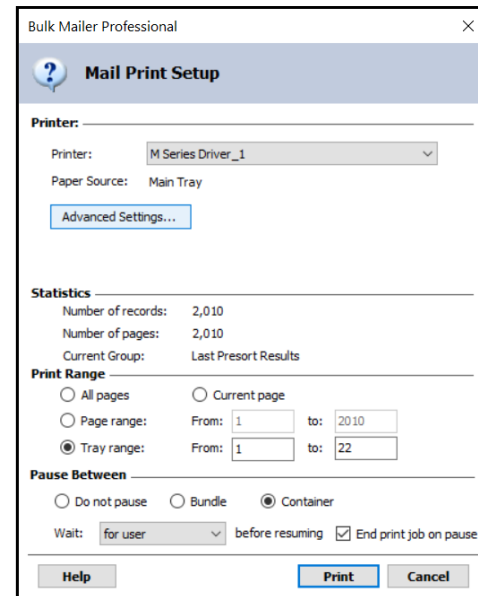

Please contact BCC Software for additional information. www.bccsoftware.com

Section 5 - Maintenance

This section covers how to perform routine operator maintenance on the printer, including Ink Tank care, Printhead care, clearing paper jams, replacing Ink Tanks, replacing Printhead Cartridge, replacing sheet separators. If printer maintenance or service is needed beyond the scope of what is covered in this section, please contact your Dealer/Distributor for support.

Note: The following information assumes that you have firmware version 20171219 or higher installed on printer.

Replacing the Ink Tanks

This procedure is almost identical to the procedure for installing new Ink Tanks into a new printer. The only differences are:

- The Toolbox will display an “Ink_Out..” condition, once the ink in a particular Tank is depleted.
- The empty Ink Tank(s) must be properly removed before installing the new Tank(s).

Procedure:

1. Open the **M Series Toolbox**.
Go to All Programs, select the “Memjet” folder, select the “M Series Driver” folder, and select (open) the “Toolbox”.
When the Toolbox opens, if any of the Ink Tanks are “empty”, you will see that the “**System Status**” information is displayed in red.

- If only one Ink Tank is empty the “**System Status:**” will be displayed as: “**INK_OUT_X**” (X = name of empty Tank).

Example “**INK_OUT_CYAN**”

- If multiple Ink Tanks are empty the “**System Status**” will be displayed as: “**INK_OUT_MULT**”, as shown in the image to the right.

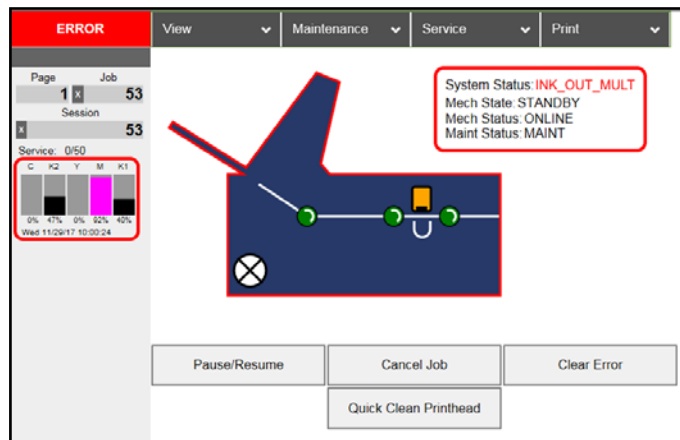

2. Select the “**Service**” drop-down menu. Select “**Replace Ink Tanks**”. (*Disconnects Printer communication with Ink Tanks and allows safe installation and replacement.*)
Once the “**Confirm**” screen displays, it is safe to remove Ink Tanks.

IMPORTANT: DO NOT press “Continue” until after you have removed and replaced the Ink Tank(s) and closed the Ink Tank Latches.

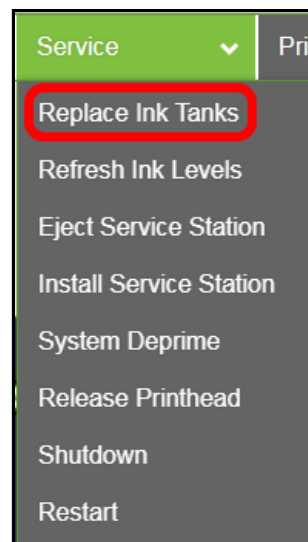

3. Open the Ink Tank Door (*hinged at bottom*).
4. Unlock the Ink Tank Securing Latch(es) [A] that correspond to the “empty” Ink Tank positions.
5. Pull the empty Ink Tank(s) out of the Printer.
6. Remove the new Ink Tank(s) from their packaging.

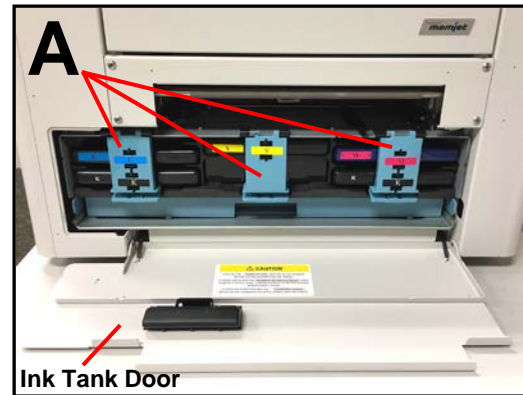

7. Insert the new Ink Tank(s) (*label side up*) into their appropriate color slots [B].

CAUTION! Be sure each Tank is installed into the proper color slot. If you force the Ink Tank into the wrong slot, you will contaminate the ink system and professional service will be required.

INSTALLATION TIP: To help ensure that the Ink Tanks are seat properly. Insert the Ink Tank into the appropriate Ink Station, then pull the Ink Tank back about an inch and push forward firmly. This will help ensure that the “septum needles” penetrate the seals on the Ink Tanks.

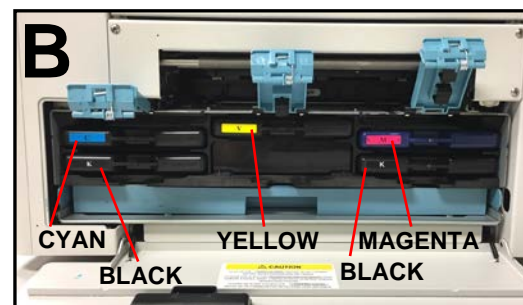

8. Close and lock all three Ink Tank Securing Latches. Make sure they are securely latched at the bottom. **IMPORTANT:** Make sure both sides of the Latch are engaged at the bottom
9. Click “Continue” on the “Confirmation” window.



10. Watch the Toolbox screen on your computer. You should see all the ink colors fill-in, if all the Ink Tanks are properly installed and recognized. **NOTE:** The image to the right shows used Ink Tanks installed. New Tanks should read 99%.

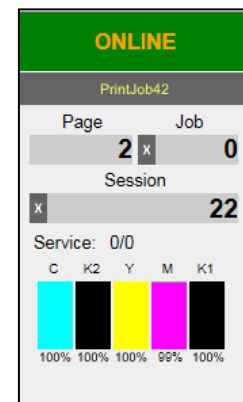

SECTION 5 MAINTENANCE

If an Ink Tank color does NOT fill-in and a question (?) mark or “Out” or “0%” condition is displayed below the ink color, this may indicate that the printer does not recognize the Ink Tank (Unable to communicate with QA Chip) or the ink level sensor doesn’t see any ink in the Tank. Verify that the Ink Tank Securing Latches are fully closed and locked. Select “**Service**” menu from the Toolbox screen. Select “**Refresh Ink Levels**”.

If the ink color still does not fill in, the QA Chip contacts, or Ink Level Prism may need to be cleaned. Please refer to the “Operator Maintenance” section for information on “Cleaning Ink Tank Contacts & Prism”.

Tip: Even new Ink Tanks can have dirty QA Chip contacts.

11. When the Printer stops processing and **System Status IS black**, the Printer is ready for use.
12. Close the Ink Tank Door.

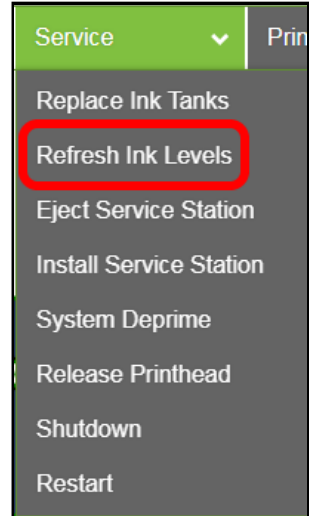

WARNING!

The ink in the Ink Tanks may be harmful if swallowed. Keep new and used Ink Tanks out of reach of children. Discard empty Ink Tanks immediately.

Cleaning Ink Tank Contacts & Prism

When reinstalling or replacing Ink Tanks, the Ink Level indicators, in the Toolbox, may show “?” or “Out” or “0%” below one or more Ink Tank positions.

- The “Out” or “0%” condition may be due to a dirty Ink Tank Level Prism or it may have occurred prematurely if the Printer is not level.
- The “?” condition may be due to dirty QA Chip contacts.

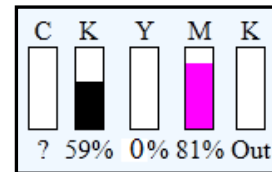

NOTICE: These conditions can also be caused by improper Ink Tank removal or install. If the printer is communicating with the Ink Tank at same time the Tank is being removed/installed, this can corrupt the QA Chip on the Ink Tank, rendering it unusable.

You can clean the Ink Tank Contacts & Prism as follows:

1. Open the Printer Toolbox.
2. **Remove Ink Tank(s).** Open **Toolbox**. Select the “**Service**” drop-down menu, then select “**Replace Ink Tanks**”. Once the “**Confirm**” window opens, it is safe to remove Ink Tanks.
IMPORTANT: DO NOT press “Continue” until after removing and replacing the Ink Tank(s) and closing the Ink Tank Latches.

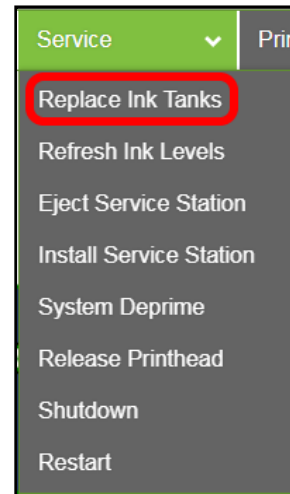

3. Open the Ink Tank Door (*hinged at bottom*).
4. Unlock the Ink Tank Securing Latch(es) [A] that correspond to the Ink Tank positions that are displaying “?” or “Out” or “0%”.
5. Remove the corresponding Ink Tank(s) from the Printer.

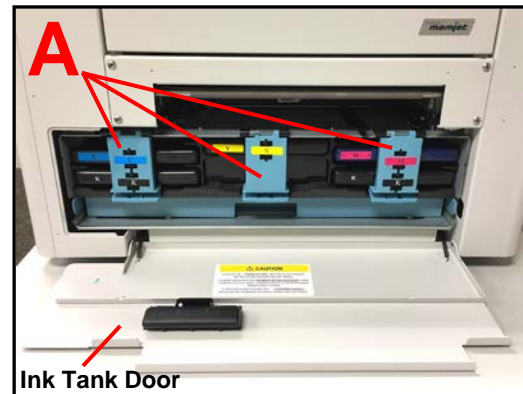

6. Clean the Ink Tank Level Prism [C] and QA Chip contacts [B] with a clean, dry, lint-free cloth. **NOTE:** You can dampen the cloth with distilled water to wipe the Prism, but Do **NOT** get the QA Chip contacts wet.
Tip: A soft pencil eraser can also be used to lightly clean the QA Chip contacts [B]. This can help remove corrosion that is not visible. Wipe the contacts off with a lint-free cloth after cleaning them with an eraser.

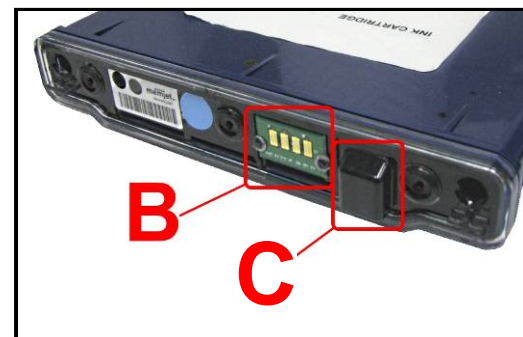

SECTION 5 MAINTENANCE

7. Re-install the Ink Tank(s) (*label side up*) into their appropriate color slots [D].

CAUTION! Be sure each Tank is installed into the proper color slot. If you force the Ink Tank into the wrong slot, you will contaminate the ink system and professional service will be required.

INSTALLATION TIP: To help ensure that the Ink Tanks are seat properly. Insert the Ink Tank into the appropriate Ink Station, then pull the Ink Tank back about an inch and push forward firmly. This will help ensure that the “septum needles” penetrate the seals on the Ink Tanks.

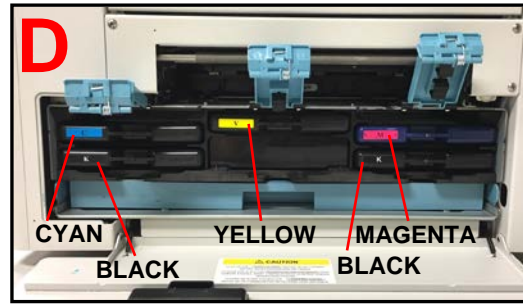

8. Close and lock all three Ink Tank Securing Latches. Make sure they are securely latched at the bottom. **IMPORTANT:** Make sure both sides of the Latch are engaged at the bottom

9. Click “Continue” on the “Confirmation” window.



10. Watch the **Toolbox** screen on your computer. You should see all the ink colors fill-in, if all the Ink Tanks are properly installed and recognized. **NOTE:** The image at right shows used Ink Tanks installed. New Tanks should read 99%.

Tip: If an Ink Tank color still does not fill-in. Select the “Service” drop-down menu, then select “Refresh Ink Levels”. If the problem continues you may need to replace the Tank with a new Tank. Even new Ink Tanks can have dirty/corroded QA Chip contacts.

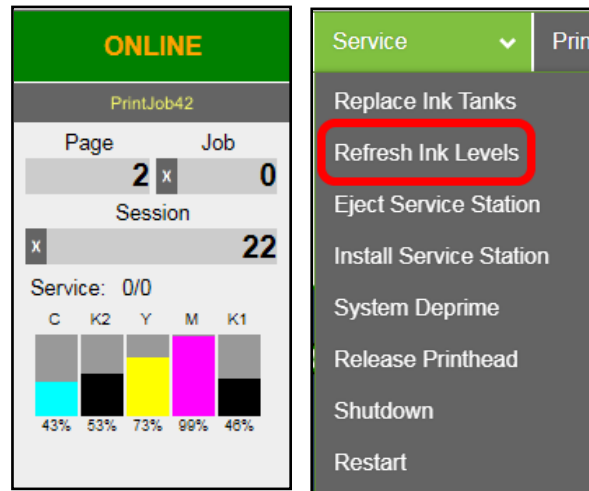

11. When the Printer stops processing and all the fields in System Status are *black*, the Printer is ready for use.

12. Close the Ink Tank **Door**.

WARNING!

The ink in the Ink Tanks may be harmful if swallowed. Keep new and used Ink Tanks out of reach of children. Discard empty Ink Tanks immediately.

Ink Tank Storage

Ink Tank storage should take place, in the original/sealed packaging, under the following conditions:

Storage Temperature Range:	Long Term: 41°F to 113°F (5°C to 45°C) Short Term: -13°F to 158°F (-25°C to 70°C) NOTE: Cumulative storage duration below 41°F (5°C) or above 113°F (45°C) must not exceed 72 hours.
Humidity Range:	5% to 95% Relative Humidity, non-condensing
Atmospheric Pressure Range:	70 kPa to 106 kPa
Electrostatic Discharge:	8 kV air discharges or 4 kV contact discharges* *When tested in accordance with IEC 61000-4-2

- Store Ink Tanks with contacts (septum seals and QA chip) facing up.
- Exposure to conditions that are not permissible may lead to damage which is not externally visible.

Opened Ink Tanks should be installed and remain in the Printer until they are empty and need to be replaced.

If you find it necessary to remove Ink Tanks from the printer, for an extended period of time, it would be best to place them in individual, sealed plastic bags. This will help to seal the Ink Tanks and protect people/property from any ink that may drip from the septum seals.

Ink Tank Service Life

Ink Tank yield will vary greatly, based on the jobs being printed. Please see “Ink Usage Menu”, in the section titled “Using the Toolbox Utility”, for details on calculating the approximate Ink Tank yield for a particular print job.

Ink Tank Disposal

Ink Tanks should be disposed of in a safe manner in accordance with local/national regulation.

Clean up spills with soap and water. Abrasive soap is effective in cleaning ink off your hands.



**The ink used in this system may be harmful if swallowed.
Keep new and used printhead cartridges and ink tanks out of reach of children.
Discard unwanted printhead cartridges and empty ink tanks immediately.**

SECTION 5 MAINTENANCE

Cleaning the Printhead Cartridge

The Printhead Cartridge is cleaned automatically, each time the printer is turned ON, periodically while the printer sits idle, before each job, periodically during the print job, and whenever a Printhead Maintenance routine is activated by the operator.

From the M Series Driver:

Three "...Clean Printhead" buttons can be found under the "Service" Tab, within the "M Series Driver Printing Preferences" window.

- **Quick Clean Printhead**
- **Normal Clean Printhead**
- **Full Clean Printhead**

Each step activates a more thorough cleaning of the printhead, in an attempt to clear and re-hydrate printhead nozzles. Each step also takes additional time to perform. See "Printer Driver Properties", "Service Tab", for more details.

Wipe Printhead - Wipes excess ink from the surface of the printhead nozzles. No ink is ejected in this process.

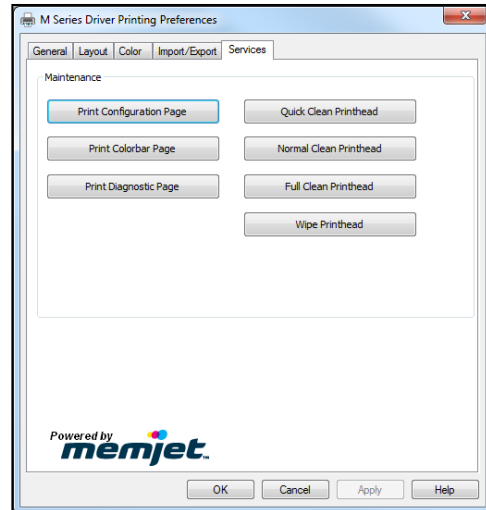

From the Toolbox:

Some of the Toolbox features, located in the **Service** and **Maintenance** drop-down menus, can be used to activate head maintenance routines.

See “**Toolbox Features**”, and “**Service**” and “**Maintenance**” drop-down menus for more details.

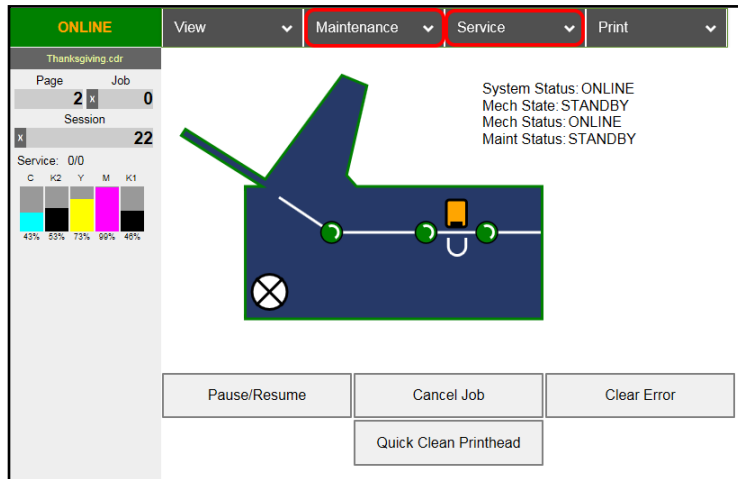

SECTION 5 MAINTENANCE

Manual Printhead Cleaning:

NOTE: We recommend the use of nitrile powder-free gloves for this process.

As a last resort, if running the built-in "... Clean Printhead" features don't help improve print quality, the printhead cartridge can be cleaned manually.

1. Carefully open the clamshell.
2. Clean the printhead nozzles. Dampen a lint-free cloth (i.e., Cartridge Wipes, PN 2023), with deionized or distilled water. Keep the printhead nozzle area facing down and gently wipe the printhead nozzle area, from end to end, in one direction and in one fluid motion. You can repeat this process a few times, but only wipe in one direction.

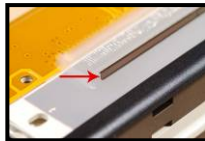

NOTE: The use of deionized water (reference ASTM D5127-90 Type E-II Electronic Grade Water) is preferred; however, it is acceptable to use distilled water if deionized water is not available. Do **NOT** use tap water or paper towels to clean the printhead nozzles. Doing so may cause damage to the printhead cartridge and possible contamination to the ink system.

WARNING: Be careful not to damage the "star rollers" when wiping the printhead. These rollers are designed so they can roll across a wet image, without damaging the image. If the rollers are bent, they will not turn free, causing media feed issues (jamming) and possible damage to the image or media.



3. Carefully Close the Clamshell.
CAUTION: To prevent damage, hold onto, then lift and release both latches when closing. If you force it closed without holding the latches open, you will eventually damage the latches and clamshell switch (door switch).

Replacing the Printhead Cartridge

ATTENTION

If you experienced fuzzy print quality or an abrupt failure in a particular area of nozzles on the previous printhead, we recommend that you have the service station inspected/cleaned and the wiper roller replaced, before installing the new printhead. If not, the chance of damage to the new printhead is greatly increased. Service station maintenance and wiper roller replacement should only be performed by a qualified/trained person. Please contact your service representative to obtain training or to have them perform this process for you.

The following procedure describes how to remove the Printhead Cartridge from the printer.

NOTE: We recommend the use of nitrile powder-free gloves for this process.

1. Plug in the printer. Turn the printer's Main Power Switch ON, then press the control panel's ON/OFF button. Wait about 45 seconds for the print engine to power-up (ON/OFF button will illuminate).
2. Open the Top Cover.
3. Open the **Toolbox** utility.
4. Select the "**Service**" drop-down menu, then select "**Release Printhead**". The printer will run a partial deprime routine and then the printhead latch will release so it can be opened.

WARNING! If the printhead latch fails to release do not force the latch open. Severe damage will result. Contact technical support.

WARNING

Never attempt to open the Printhead Latch manually, when in the closed/locked position. Severe damage will result. Use the Release Printhead button from the Toolbox Utility.

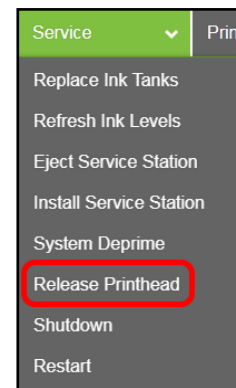

5. Open the Printhead Latch fully to disengage the ink couplings from the printhead cartridge.
6. Remove the old printhead as shown below. Tilt the cartridge back and then lift up to remove.

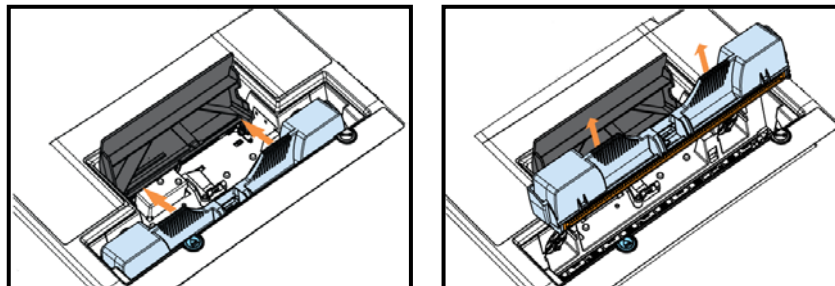

7. To help reduce ink spills, place the printhead into the old protective packaging and discard.
8. Once the old Printhead Cartridge has been removed, please refer to the section titled "Installing the Printhead Cartridge", to install the new Printhead Cartridge.

Printhead Storage

Printhead storage should take place, in the original/sealed packaging, under the following conditions:

Storage Temperature Range:	Long Term: 41°F to 113°F (5°C to 45°C) Short Term: -13°F to 140°F (-25°C to 60°C) NOTE: Cumulative storage duration below 41°F (5°C) or above 113°F (45° C) must not exceed 72 hours.
Humidity Range:	5% to 95% Relative Humidity, non-condensing
Atmospheric Pressure Range:	70 kPa to 106 kPa
Electrostatic Discharge:	8 kV air discharges or 4 kV contact discharges* *When tested in accordance with IEC 61000-4-2

- Store the printhead with the printhead nozzles facing down. This helps to ensure that the shipping fluid, within the printhead, keeps the nozzles hydrated during printhead storage.
- Exposure to conditions that are not permissible may lead to damage which is not externally visible.

Once the vacuum sealed packaging has been opened, the printhead should be immediately installed and it should remain in the printer until it is determined that printhead replacement is required.

If you find it necessary to remove the printhead from the printer, it must be properly protected and sealed to help reduce damage, nozzle dehydration and clogging.

- Follow the “Replacing the Printhead Cartridge” procedure to remove the Printhead Cartridge.
- Install the protective cover on the Printhead. Be careful to avoid ink spills (drips) and stains during this process.
- Store Printhead Cartridge in a sealed plastic bag, along with a small lint-free cloth that has been lightly dampened with distilled water. This will create a humid atmosphere to help prevent nozzle dehydration.
- Reinstall the “Cap Protectors” onto the Ink Revolver Couplings to protect the ink system from dust and debris.
- The Printhead should be re-installed as soon as possible.

Please see the section titled “Installing the Printhead Cartridge”.

CAUTION: Make sure the cartridges electrical contacts are dry before re-installing Printhead.

Printhead Service Life

Manufacturer’s estimated rating: ~125,000 linear inches of continuous printing.

For example, if printing a #10 envelope (9.5” W x 4.13” H), feeding long-edge first, at best print quality, with 100% ink coverage (each nozzle firing at 1600 dpi down length of media), the printer is depositing 4.13 liner inches of print per piece. At this rate, you can expect a yield of approximately 30,000 envelopes before head replacement may be needed.

If printing a typical logo (1” high) you can expect a yield of approximately 125,000 envelopes before head replacement may be needed.

NOTICE: Individual results will vary.

The estimations, provided above, are NOT an expression of Warranty. This information is being provided for informational purposes only. The decision on when a printhead is no longer producing acceptable output varies greatly from customer to customer, since this decision is based upon the customer’s expectations (what they consider as acceptable output).

Printhead degradation will depend on the make-up of the images printed, the operating environment, servicing, media characteristics (*including cleanliness*) and other factors. The Printhead has a total of 70,400 nozzles (14,080 per color channel, 5 color channels). Since every print job is different, most do not use the entire width of the Printhead, nor do they require that every nozzle be fired. Therefore, some nozzles do not fire as often as others. The most frequently used nozzles will begin to fail (nozzle “end-of-life”) before nozzles that are used less often. Noticing the effects of failing nozzles depends partly on the relative position of those nozzles to each other.

Printhead Disposal

The Printhead Cartridge should be disposed of in a safe manner in accordance with local/national regulation. To help avoid ink spills, place the Printhead Cartridge back into its original packaging before disposal. Clean up spills with soap and water. Abrasive soap is effective in cleaning ink off your hands.

Inspecting & Cleaning the Lip of the Capping Station

The Capping Station (Cap) is part of the Service Station. When the printer is idle, the Service Station automatically caps the printhead to keep the nozzles hydrated.

Excess ink can accumulate on the Lip of the Cap. This commonly occurs after a printhead cartridge is installed and the system is primed. During the printhead priming process the system performs multiple purges of ink into the Cap. This can cause excess ink to build on the lip of the Cap. This excess ink will then be transferred to the printhead surface, when the printhead is capped, creating a greater chance for “scuff marks” to occur on the media.

Procedure:

1. Power-down the printer using the ON/OFF button.
2. After the Control Panel Lights have all turn OFF, Open the Top Cover.
3. Carefully release the Latches and Open the Clamshell.



4. Using a lint free cloth, carefully wipe the excess ink from the Lip of the Capping Station.

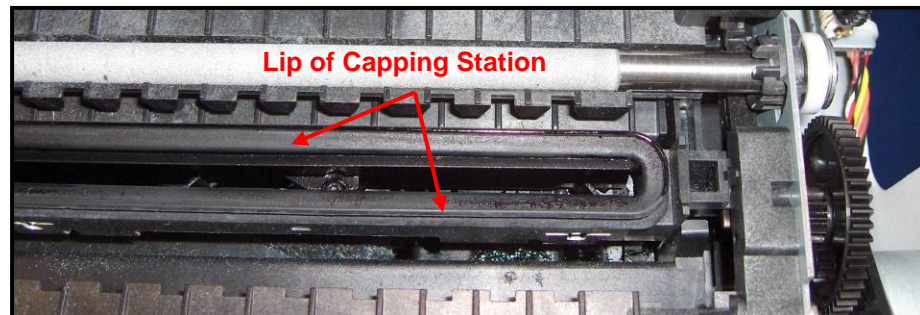

5. Inspect the lip of the cap for signs of wear or damage. If the lip is uneven or cracked, it should be replaced. Please contact your service support representative to have this item replaced.
6. Carefully close and latch the Clamshell.
Important! Make sure to hold the latches open (unlocked position) until the clamshell is closed. Then slowly release the latches. If this rule is not followed damage to the latch posts and or door switch may result.
7. Close the Top Cover.
8. Power-On the printer.

SECTION 5 MAINTENANCE

Inspecting the Wiper Roller

The Wiper Roller should be routinely inspected for signs of wear and debris.

NOTICE! If you have not been trained or are uncomfortable performing this task, please contact your service support representative.

Directions:

1. Power ON the printer and power-up the print engine.
2. Open the Top Cover.
3. After the printer has finished performing maintenance, carefully release the Latches and Open the Clamshell.
4. Open the Toolbox and press the “Wipe Printhead” button. When the “Wipe Printhead” warning message, “Are you sure you want to continue?”, appears, Click on YES.



5. The Wiper Roller will be presented through the opening in the lower section of the print engine. The Service Station will cycle through its normal wiping and capping routine, providing you with the opportunity to inspect the condition of the Wiper Roller.

CAUTION: Keep all loose items and hands away from the moving parts within the print engine. Do NOT try to touch or clean the moving components. Injury or damage may result.

TIP: If you find that the “Wipe Printhead” feature isn’t working (wiper not presented), press the Wipe button while the Clamshell is shut, then open the Clamshell to inspect the wiper roller.

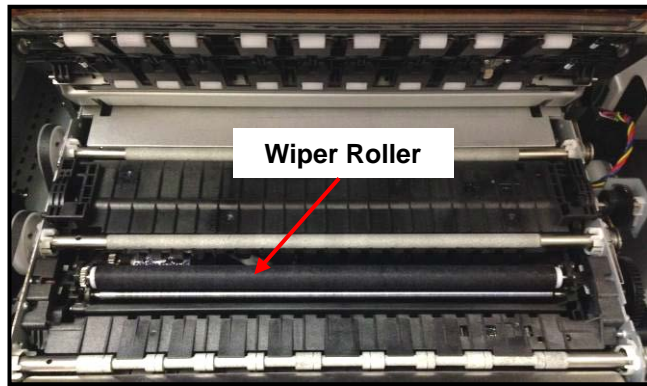

6. Inspect the Wiper Roller for signs of damage/wear (fabric is fuzzy, torn, uneven) and debris (fibers, hair, particle accumulation, etc.). Contact your service support representative if you see signs of wear or debris on the roller. The wiper roller may need to be cleaned or replaced.
NOTE: A new (unused) Wiper Roller will be white. Once the roller has been used, for a very short period of time, it will turn black with ink. This is normal.
WARNING: Without training and experience it can be difficult to identify a worn or dirty wiper roller. When in doubt, the Wiper Roller should be replaced. Operating the printer with a worn or dirty wiper roller can cause damage to the printhead. If the printhead is replaced it is also recommended that the Wiper Roller be replaced at the same time.
7. As soon as you are finished inspecting the Wiper Roller, carefully close and latch the Clamshell.
WARNING: If you leave the Clamshell open too long this may cause nozzle dehydration.
Important! Make sure to hold the latches open (unlocked position) until the clamshell is closed. Then slowly release the latches. If this rule is not followed damage to the latch posts and or door switch may result.
8. Close the Top Cover.

Cleaning/Replacing Service Station Items

The Service Station contains separate areas/devices that are used to perform the following tasks.

- **Cleaning.** The Wiper Roller cleans the Printhead nozzles of excess ink and debris.
- **Printing/Purging.** The Printing Platen acts as a base to support media during printing. It also contains a purging area, which captures and absorbs ink that is purged, to help keep nozzles clear.
- **Capping.** The Capping Station seals and protects the printhead nozzles when not in use.
- **Evacuating Waste Ink.** In addition to the function of supporting the above items, the Service Station Tray is lined with wicking material that absorbs the waste ink and transfers it out of the Tray and into the “waste ink trough”. This waste ink then flows from the “trough” to the “Waste Ink Tray”, which is located under the Print Engine, behind the Ink Tank Door.

As the above components become worn/dirty, from use, they can lose their ability to perform as intended. If you experience print quality issues that are not resolved by performing the steps found in the Troubleshooting Section under “Print Quality Issues”, it may be time to have the Service Station, or components within the Service Station, cleaned or replaced.

CAUTION

THESE PROCEDURES SHOULD ONLY BE PERFORMED BY A QUALIFIED/TRAINED PERSON.

NOTICE: Due to the technical nature of these procedures, they should only be performed by a qualified technical support person or someone that has been properly trained on these procedures. Please contact your technical support representative. Please use nitrile powder-free gloves and have plenty of paper towels on-hand for these procedures.

WARNING

If the Printhead Cartridge is still installed, when you remove the Service Station, the Printhead will remain un-capped. This can cause dehydration of nozzles and printing issues. If you want to reduce the chance for printhead nozzle dehydration, it is highly recommended that you eject the Printhead and follow the procedures described under “Printhead Cartridge Storage and Handling” before you begin this process.

Removing the Service Station

1. Open the Top Cover
2. Open the Ink Tank Door (*hinged at bottom*) to expose the “Service Station Slot”.

Tip: On older units you will need to remove the Exit Roller Cover by removing the four (4) screws. This is not necessary on newer units.

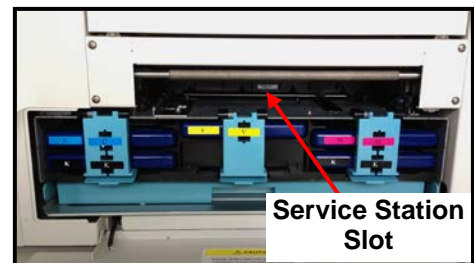
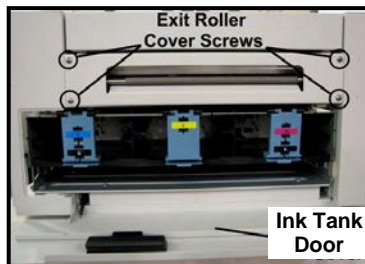

SECTION 5 MAINTENANCE

3. Power-up the printer.
4. Open the **Printer Toolbox**.
Open the “**Service**” drop-down menu. Select “**Eject Service Station**”.
5. Once the Service Station has ejected, power OFF the printer.
Press the ON/OFF button once and wait about 45 seconds for the print engine to power off (all control panel light’s off).
Then turn the Main Power Switch OFF.

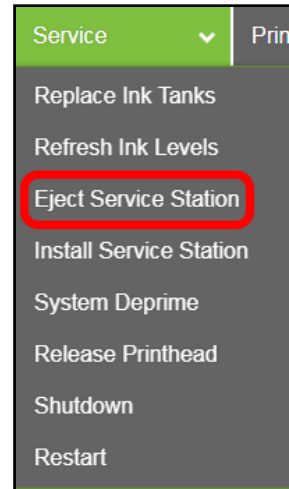

6. Slide the Service Station out of the Service Station slot.
CAUTION: There is a Ribbon Cable attached between the service station and the print engine. Do not pull the Service Station out too far, with this cable connected, or you may damage the system.

NOTE: It is a good idea to place an absorbent towel under the Service Station, as you remove it, to catch any ink drips or leaks.



7. Disconnect the Ribbon Cable.
Slide the black Latch OPEN [2] on the Service Station Circuit Board to release the Ribbon Cable.
CAUTION! This black latch can be broken if you pull it out too far. Be careful!



8. Remove the Service Station completely from the print engine and place it on a non-absorbent surface (plastic bag) to protect the surface you are placing it on.
9. If you are cleaning or replacing items in the service station, please see the next section titled “Cleaning the Service Station”.
10. If you are replacing the Service Station, carefully remove the new Service Station from its packaging.
NOTE: Loose parts may fall out. Keep roller side facing up.
Please see the section titled “Installing the Service Station”.



Cleaning the Service Station

Caution: Please be sure that you are using proper cleaning techniques to clean items that come in contact with the printhead. Use only distilled or deionized water and lint free cloths. If you don't follow this rule, you will introduce contamination into the printhead, which can damage the printhead and ink system.

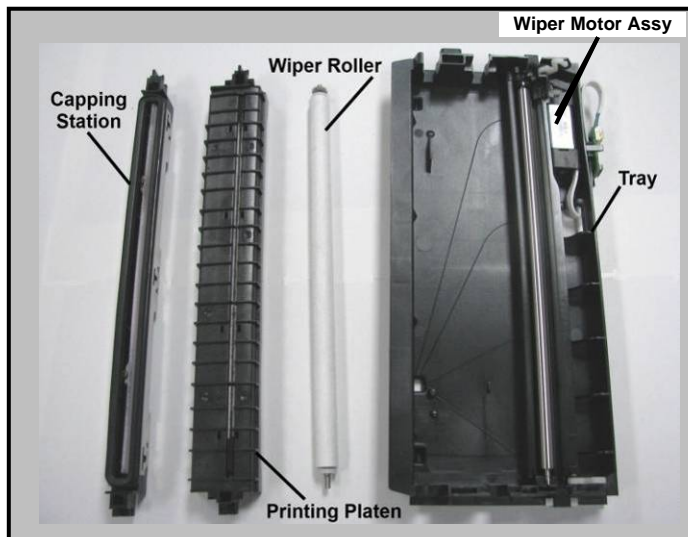

Wiper Roller Removal and Cleaning or Replacement

Tip: Although the wiper roller can be cleaned, this process is time-consuming. When you factor in labor costs, you may find it more cost-effective to replace the wiper roller instead. We also recommend that the wiper roller be replaced whenever a new printhead is installed.

Removal:

1. Lift up, about one inch, on the Wiper Motor Assembly, to expose the latch retaining screws [C] (one at each end).
NOTE: Early versions of this assembly did not have retaining screws.
2. Carefully loosen the two small screws retaining the wiper roller latches.
Tip: To avoid losing these screws, don't remove the screws. You only need to back-out the screws far enough so the latches can be opened.
3. Release the two latches that secure the wiper roller.
4. Remove the Wiper Roller from the Wiper Motor Assembly.

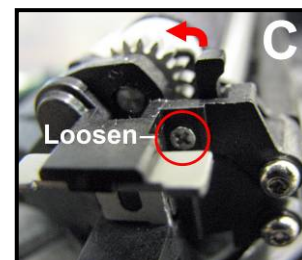

Cleaning/Replacement:

1. Using distilled water, immerse for 10 minutes, then remove and pat dry with absorbent lint free towel.
WARNING! Do NOT rub the roller, when cleaning or drying it. This will cause damage to the roller fabric. Do NOT use tap/mineral/spring water to clean the wiper roller, doing so will introduce contaminants into the roller. A contaminated roller will cause damage to the printhead and ink system. Allow the roller to dry completely, before re-installing it.
2. If the Wiper Roller shows signs of wear (fabric surface torn, un-even or fuzzy), it should be replaced. **Be sure to remove the plastic cover from the new Wiper Roller before installing it.**

Install:

1. Re-install the Wiper Roller into the Wiper Motor Assembly. Make sure the gear on the Wiper Roller engages the gear in the Wiper Motor Assembly.
TIP: If you are planning to clean the Wiper Motor Assembly, don't re-install the wiper roller until you have completed the Wiper Motor Assembly cleaning process.
2. Carefully close the latches. Make sure the latches are fully locked and then tighten the latch retaining screws [C] (don't over-tighten).

SECTION 5 MAINTENANCE

Wiper Motor Assembly Removal and Cleaning

Removal:

1. Disconnect (unplug) the wiper motor cable from the Service Station Printed Circuit Board [A].
2. Remove the Printed Circuit Board [A] from the Service Station Tray. Carefully release clips to remove board.
3. Lift the Wiper Motor Assembly [B] from the Tray. The motor wires can be pulled through the hole in the side of the tray.
4. Remove the Wiper Roller from the Wiper Motor Assembly. See procedure on previous page.

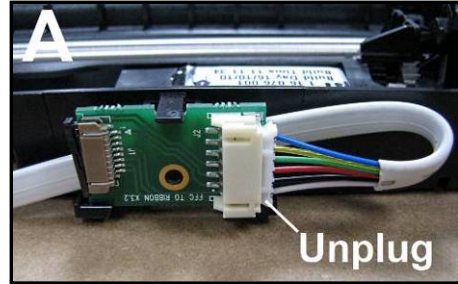

Cleaning:

1. Pour distilled water into a flat-bottom container to the depth of about 17mm.
2. Carefully immerse the Wiper Motor Assembly, motor side up, into the water.

WARNING

DO NOT IMMERSE MOTOR OR GET MOTOR WET, TO AVOID DAMAGE.

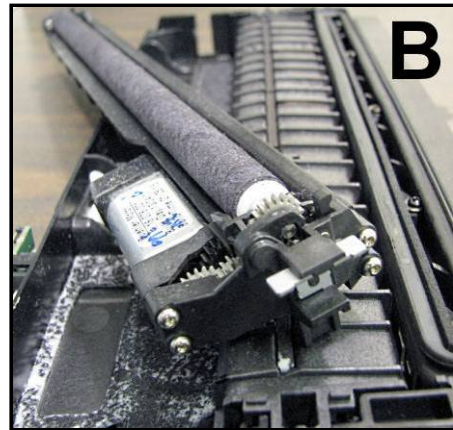

3. If vents are showing, carefully add more water until they are covered. Allow the Wiper Motor Assembly to soak for 10 minutes.
4. Carefully remove the Wiper Motor Assembly from the water. Inspect the vents and remove any debris with tweezers. Pat dry with an absorbent lint-free towel.
NOTE: If this assembly shows signs of wear or damage it should be replaced. If the Service Station is more than one year old, depending on monthly volume, it may be worthwhile to replace the entire Service Station instead of replacing components.

Install:

1. Allow the Wiper Motor Assembly to dry.
2. Lightly lubricate the three Wiper Motor Gears [D] with synthetic PTFE grease (Super Lube 21030 or equivalent).
3. Re-install in reverse order.
NOTE: Make sure the wiper roller is re-installed, wiper roller latches are fully closed/locked and the wiper roller retaining screws are fully tightened (do not over-tighten).
TIP: If you are planning to clean the Service Station Tray, don't re-install this component until you have completed the Service Station Tray cleaning process.

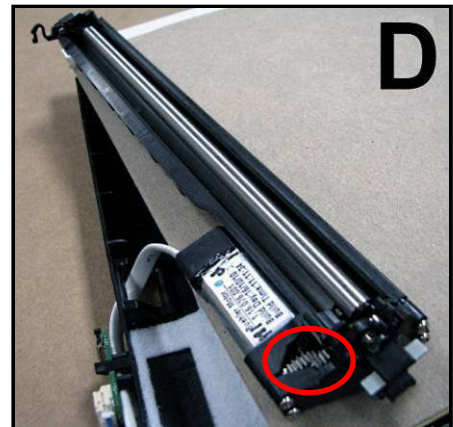

Printing Platen and Capping Station Removal and Cleaning

Removal:

Both of these items [A] simply lift out, for removal from the Service Station.

Cleaning:

1. Rinse off ink using tap water.
Tip: Make sure the valve, located on the bottom of the Capping Station, is clear of debris and working.
2. Pat dry with an absorbent lint-free cloth.
3. After cleaning the Capping Station, wipe the capping lip with a lint free cloth, dampened with distilled water. This will help ensure that the contaminants on the cap are removed before the cap makes contact with the printhead.

NOTE: If either of these items show signs of wear or damage they should be replaced. If the Service Station is more than one year old, depending on monthly volume, it may be worthwhile to replace the entire Service Station instead of replacing components.

Install:

1. Allow the Printing Platen and Capping Station to dry.
2. Reinstall Printing Platen and Capping Station into Service Station Tray.
TIP: If you are planning to clean the Service Station Tray, don't re-install this component until you have completed the Service Station Tray cleaning process.

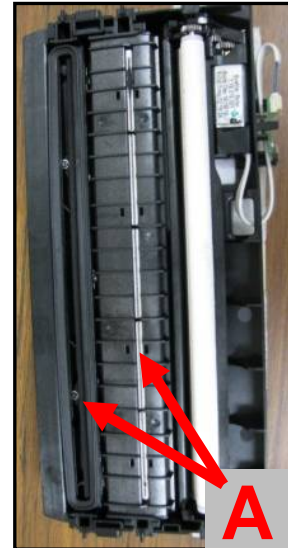

Cleaning the Service Station Tray

1. If present, remove the Service Station Printed Circuit Board, Wiper Motor Assembly, Printing Platen and Capping Station from the Tray, as described on the previous sections/pages.
2. Wipe the Tray with a damp, lint-free cloth to remove the major ink buildup. Be careful not to damage/peel-off the wicking material, from the surface of the Tray.
3. Then rinse the Tray using tap water.
4. Allow the tray to dry.
NOTE: If the Tray shows signs of wear or damage (wicking material torn or coming loose from surface of tray) the Tray should be replaced. If the Service Station is more than one year old, depending on monthly volume, it may be worthwhile to replace the entire Service Station instead of replacing components.
5. Reinstall the Service Station Printed Circuit Board, Wiper Motor Assembly, Printing Platen and Capping Station, into the Tray, as described on the previous pages.

Suggestion for High Volume Users:

For printers that are being used at high volumes (over 200,000 pieces per month), we recommend purchasing a second service station to reduce down-time for Service Station Maintenance. The new/clean service station can be swapped with the dirty one. Then the dirty Service Station can be cleaned, as described on the previous pages, and made ready for the next time Service Station Maintenance is required.

Installing the Service Station

CAUTION

THIS PROCESS MUST BE PERFORMED BY A QUALIFIED/TRAINED PERSON.

NOTICE: Due to the technical nature of this procedure, it should only be performed by a qualified technical support person or someone that has been properly trained on this procedure. Please contact your technical support representative. Please use nitrile powder-free gloves and have plenty of paper towels on-hand for these procedures.

The Service Station fits in the slot immediately above the Ink Tank slots.

PROCEDURE:

1. Make sure the printer is powered OFF.
If the printer is not powered off, press the ON/OFF button once and wait about 45 seconds for the print engine to power off (all control panel light's off). Then turn the Main Power Switch OFF.
2. Open the Top Cover.
3. Open the Ink Tank Door (*hinged at bottom*) to expose the "Service Station Slot".

Tip: On older units you will need to remove the Exit Roller Cover by removing the four (4) screws. This is not necessary on newer units.

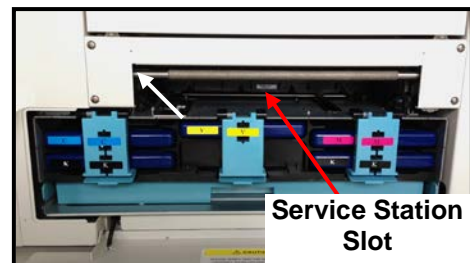
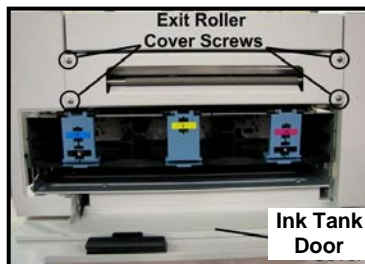

4. If you are installing a New Service Station, carefully remove the Service Station from its packaging.
NOTE: Loose parts may fall out. Keep wiper roller side facing up, when removing the packaging.
5. Check to be sure that the wiper roller latches are secure.

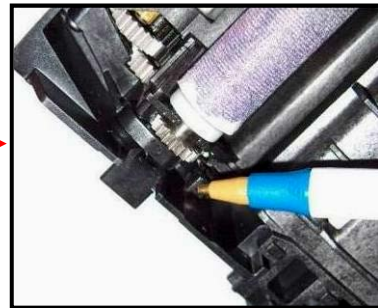
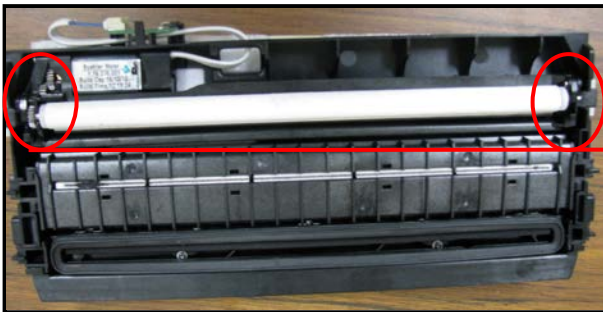

Check the latch at each end of the wiper roller.

CAUTION!

**Make sure the latches for the Wiper Roller are fully latched and secured before installing the Service Station. Current versions of this assembly also have latch retaining screws that secure the latches from opening in transit or use. Make sure these screws have been tightened (do NOT over-tighten).
NOTE: Early versions of this assembly did not have latch retaining screws.**

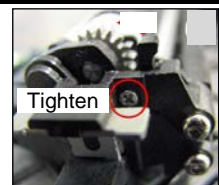

6. Slide the Cable Securing Latch OPEN on the Service Station Circuit Board, as shown below.

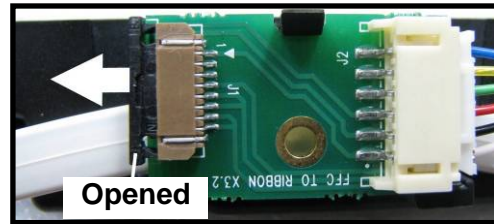
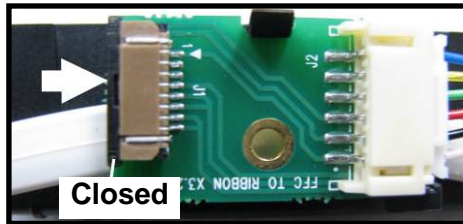

7. Locate the Ribbon Cable (from within the Service Station Slot).
Insert the Ribbon Cable (blue side up) into the space under the Cable Securing Latch [1].
Make sure the ribbon cable is pushed in all the way and is NOT crooked. Then CLOSE the Cable Securing Latch [2].

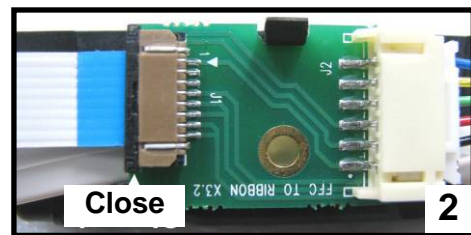
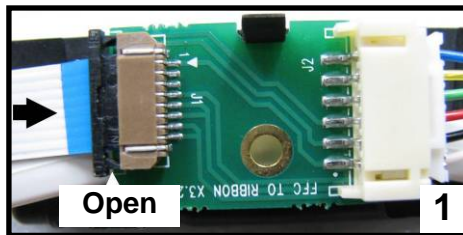
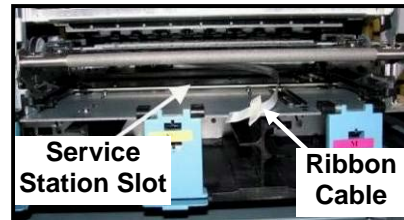

8. Once the Ribbon Cable is properly connected to the Service Station Circuit Board, gently slide the Service Station, wiper roller end first, into the Service Station Slot until it stops. The Service Station fits into the slot immediately above the Ink Tank slots.
NOTE: The Ink Tank Door must be open to perform this procedure.

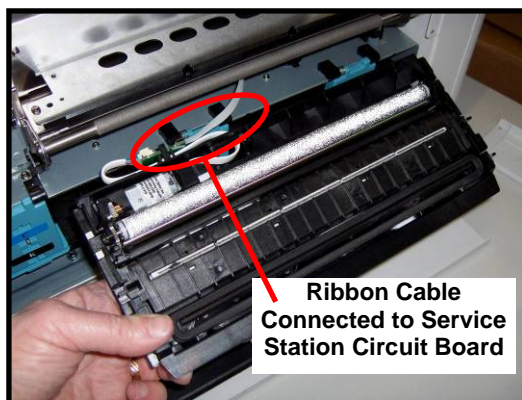

SECTION 5 MAINTENANCE

- Carefully Open the Clamshell.
- Look down through open area, in the Print Engine, to make sure the Service Station is aligned with the “Bar”, (Service Station Drive Shaft) as shown.

If the Printhead Cartridge is not installed (has been removed), you can look down through the top of the Print-Engine, through the Printhead Cartridge opening.

If the Printhead Cartridge is still installed, you must open the Clamshell to see into this area, as shown.

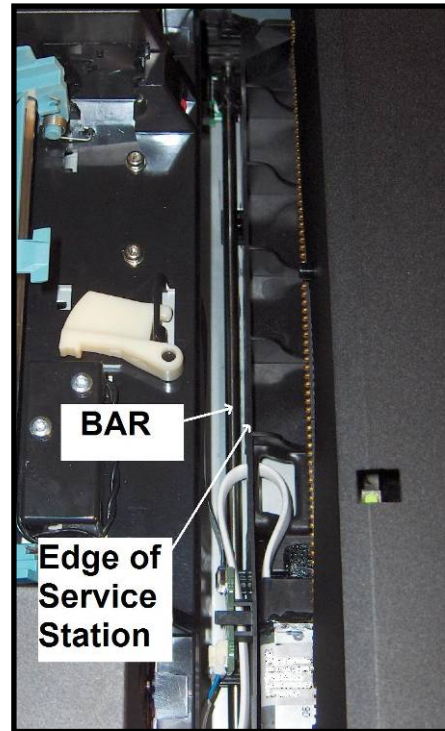

IMPORTANT!

The Service Station must perfectly align with the “Bar” to prevent misalignment and jamming of the service station.

- GENTLY push in on the Service Station with one hand, while slowly turning the “Large Gear” clockwise with the other hand. It should be easy to turn this gear and the service station should start to drive into the print engine squarely. Once the Service Station moves about ¼ inch past the “Bar” (shown in previous step), stop turning the gear. Do NOT manually drive the Service Station into the print engine beyond this point.

NOTE: The “Large Gear” is located on the non-operator side of Print Engine, as shown below. You don't need to open the Print Engine to access this gear.



You don't need to open the Print Engine.
Shown for clarification purpose only.

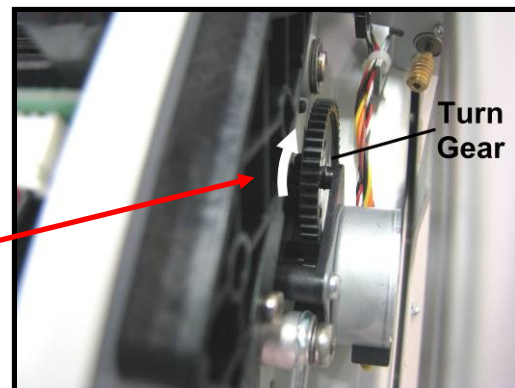

- Turn the printer's Main Power Switch ON, then press the control panel's ON/OFF button. After printer initialization (~45 seconds) the Print Engine will automatically pull the Service Station the rest of the way in.

NOTICE: If the Service Station should get jammed during this process (you hear motor stall noise or gear slipping noise), immediately turn OFF the printer's Main Power Switch. This is one of the few exceptions for turning off the printer using the main power switch, before properly powering-down the print engine. Remove the Service station by turning the Large Gear counter-clockwise. Recheck that the Wiper Roller is properly installed and latched at each end. Then re-install the Service Station starting from step 8 above.

Tip: The "Eject Service Station" button, located in "Service" drop-down menu in the M Series Toolbox, should be used if the service station needs to be removed in the future.

- Verify that the wick, located on the bottom of the Service Station, is hanging into the waste ink trough, as shown (as viewed looking into the Service Station Slot, from the exit end of the printer).



WARNING

Waste-ink from the Service Station flows through wicking material and out the hole, located on the bottom of the service station. If this wicking material is not directed into the trough, waste-ink will build up on the base of the Service Station Slot. This misdirected waste-ink will eventually find its way onto the Ink Tanks, inside the body of the printer and even under the printer, causing damage to the system.

- Carefully close and lock the Clamshell.

- Close the Ink Tank Door.

NOTE: If using an older printer, you will need to re-install the Exit Roller Cover plate, using the 4 screws, before closing the Ink Tank Door.

Make sure the cover is installed in the proper orientation.

TIP: Since the Exit Roller Cover is also an integral part of the frame structure, you may need to push in on the outer frames to get the screw holes in the Exit Roller Cover to align.

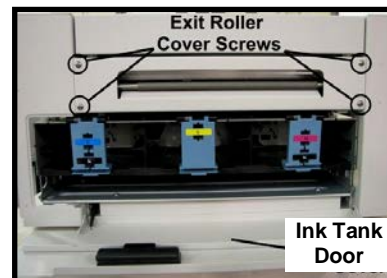

- Close the Top Cover

- Power the printer on and Test for proper operation.

Still Experiencing Print Quality Issues?

If you still experience print quality issues, after performing all the cleaning processes, outlined in this section, please refer to the "Troubleshooting Guide" for additional help. If you have exhausted all cleaning and troubleshooting options, and you have replaced the Printhead Cartridge and Wiper Roller, then this may indicate that the printer requires technical service. Please contact your support representative to schedule a service call.

SECTION 5 MAINTENANCE

Inspecting/Replacing the Waste Ink Tray

The Waste Ink Tray is filled with an absorbent material, used to capture the waste ink that drains from the Service Station.

1. If the printer is on, press the ON/OFF button to power-down the print engine. Wait about 45 seconds until the system shuts down (all control panel lights will go off). Turn off the Main Power Switch and unplug the printer from the power receptacle.
WARNING! If this power-down process is not followed, ink color mixing and printhead nozzle clogging may result.
2. Unplug the power cable from the printer.
3. Open the Ink Tank door
4. The Waste Ink Tray is secured to the print engine frame by two tabs. One tab is located at the left side of the tray and one at the right side. Simultaneously push the two tabs in towards the tray, while pulling the tabs out towards you. The Waste Ink Tray should release from the frame and begin sliding towards you.
5. Slide the Waste Ink Tray out from under the print engine.
6. If the absorbent material is saturated with ink (entire white absorbent pad is now colored with ink), the Waste Ink Tray should be replaced.
WARNING: Do NOT remove the Waste Ink Tray for more than a minute or two. With the tray removed, waste ink will drip onto the base of the printer. This ink will eventually end up in areas that are undesirable, causing damage to the system or other items/properly.
7. When re-installing the Waste Ink Tray, push the tray in evenly and slide it all the way back until it stops. Make sure the tray securing tabs snap into the print engine frame.

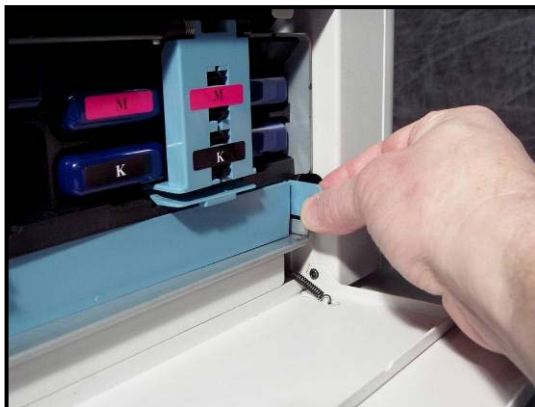
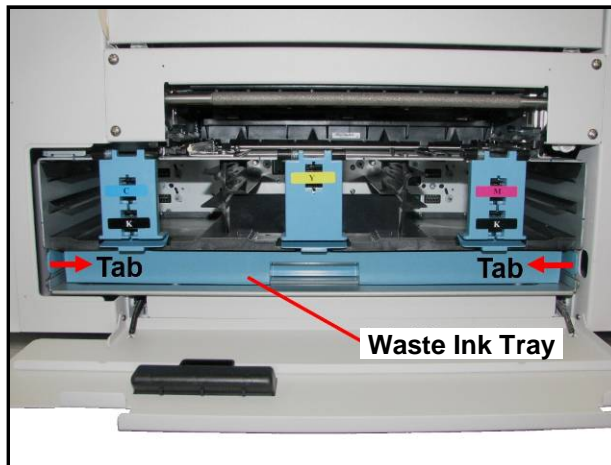

Replacing the Sheet Separators

The sheet separators (90-103-09) ensure separation of the pieces as they are being fed. If you experience double sheet feeding and cannot adjust the separators to prevent this, replace the separators.

Replacing the sheet separators is not difficult, however, if you don't feel confident about doing this yourself, please contact your technical support person.

1. Turn OFF the printer. If the printer is on, press the ON/OFF button to power-down the print engine. Wait about 45 seconds until the system shuts down (all control panel lights will go off), then turn off the Main Power Switch.

WARNING! If this power-down process is not followed, ink color mixing and printhead nozzle clogging may result.

2. Unplug the power cable from the printer.
3. To gain access to the separators, loosen the Side Guide Locking Knobs and move both Media Side Guides to their maximum outer positions.
4. Loosen the Separator Locking Screws, then raise and lock each sheet separator at its upper position.

5. Remove the screw [A] and the separator cover [B]. Then remove the separator [C] by gently prying it out of the holder. Repeat for all four sheet separators.
CAUTION: Be careful that you don't drop the screws into the printer during this process.

6. Install a new separator. Install the separator cover and secure with the screw. Repeat for all four separators.
CAUTION: Don't over-tighten the screw or you will bend the separator cover.

7. Readjust the Sheet Separators and Media Side Guides to accommodate your media. Refer to the section titled "Setting up the Feed" for details.

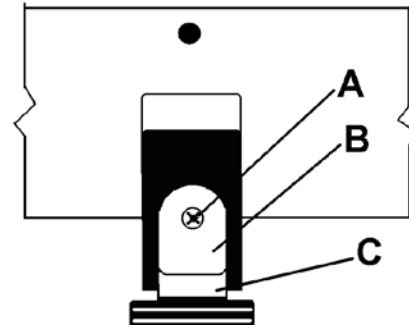

SECTION 5 MAINTENANCE

Clearing Media Jams

When the printer detects a media feed problem, it will stop automatically.

Depending on where the media stops, the message “PAPERPATH_PAPERJAM” or “PAPERPATH_FEED_TIMEOUT” will be displayed in the Toolbox.

Once the jam has been removed from the system and the print engine is closed, press the PAPER/RESUME button on the control panel or press the Clear Error button in the Toolbox to continue printing.

Some possible causes for jamming are:

1. Feeding more than one piece of media at a time (double-feeding), due to improper sheet separation adjustment, improper media loading, or nested media (envelopes that are caught under the flap of another envelope or stick to one another).
2. Damaged media, such as dog-eared (turned down corners), curled or bowed media.
3. Media that is not stiff enough may not be usable. Media that meets Postal stiffness requirements for automated feeding is acceptable in the MACH 5 printer. **Tip:** Try removing the PPS spacers.
4. Media that is too thick for the printer.
5. Media that is too wide for the printer or media that skews as it travels through the printer.
6. Media that is too short in length (below 4.125” in length).
7. Media that has colors on the underside, which pass over the Paperpath Exit sensor.

Tip: If you are getting a paper jam message, but you are not seeing a physical jam. Clean the Paperpath and Feed sensors. If the issue continues, try selecting the “Ignore Exit Sensor” feature in the Toolbox.

Removing Jammed Media

Clearing a jam depends on where the jam occurred.

From the Feed Section: Remove media stack. Loosen and lift the sheet separators to clear the jam. Then re-adjust the sheet separators as described in this manual.

Under the Antistatic Brush Assembly: If necessary, remove the Antistatic Brush Assembly [A] to access jammed material. Unlatch the two latches (one on either side of the Assembly) and lift the assembly off the four mounting pins as shown. **Do not bend the fingers!** Clear the jam, and then carefully reinstall the Antistatic Brush Assembly. Make sure brush assembly is correctly reinstalled and aligned before starting to print. Assembly should sit flat on transport area surface

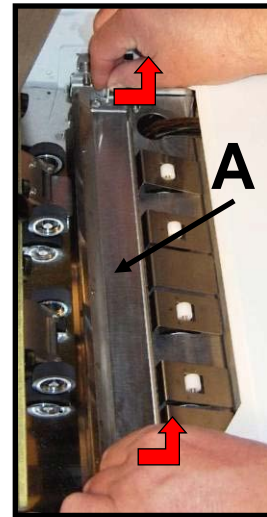

CAUTION

BE CAREFULL NOT TO PINCH OR CUT THE INK HOSES WHEN RE-INSTALLING THE ANTISTATIC BRUSH ASSY.

From the Print Engine Area: Open the Top Cover. Lift up on the two latches (*one on each side of the print engine assembly*) and raise (swing open) the Clamshell [C]. Clear the jam, then lower and re-latch the Clamshell. Then close the Top Cover.



CAUTION

HOLD ONTO BOTH LATCHES WHEN OPENING AND CLOSING THE PRINT ENGINE CLAMSHELL TO PREVENT DAMAGE.

Double-Feeds

Double-feeds, or overlapping media, can be corrected by readjusting the Sheet Separators (See Setting up the Feed), or replacing the sheet separators (See “Replacing the Sheet Separators”).

Cleaning the Printer Body

WARNING

**THE PRINTER IS A PRECISION MACHINE THAT SHOULD BE CLEANED REGULARLY TO INSURE MANY YEARS OF SERVICE. BEFORE PERFORMING ANY MAINTENANCE, DISCONNECT THE MACHINE FROM ITS POWER SOURCE!
DO NOT REMOVE SIDE COVERS! HIGH VOLTAGES PRESENT.**

Clean the Printer regularly to remove accumulated paper dust and ink. Depending on the types of media that are run, paper dust may accumulate inside the printer and on the transport.

1. If the printer is on, press the ON/OFF button to power-down the print engine. Wait about 45 seconds until the system shuts down (all control panel lights will go off). Turn off the Main Power Switch and unplug the printer from the power receptacle.
WARNING! If this power-down process is not followed, ink color mixing and printhead nozzle clogging may result.
2. Unplug the power cable from the printer.
3. Interior: Use a vacuum with a soft brush attachment to help loosen dust particles. Take care not to damage the PC Boards or electrical wiring.
4. Exterior: Wipe clean with a lint-free cloth using any standard nonabrasive household cleaner that does not contain plastic harming solvents.

CAUTION

NEVER SPRAY OR POUR CLEANERS DIRECTLY ON OR INTO THE PRINTER. EXCESS LIQUID COULD HARM ELECTRONIC PARTS. DAMPEN A LINT-FREE CLOTH WITH THE CLEANER AND APPLY IT TO THE PARTS TO BE CLEANED.

SECTION 5 MAINTENANCE

Cleaning the Feed Rollers and Forwarding Rollers

The rubber Feed Rollers [A] and Forwarding Rollers [B] can become glazed with paper lint and ink from the media. They should be routinely cleaned with a mild household cleaner on a damp lint-free cloth.

NOTE: Do NOT use solvents to clean the Rubber Rollers.

1. If the printer is on, press the ON/OFF button to power-down the print engine. Wait about 45 seconds until the system shuts down (all control panel lights will go off). Turn off the Main Power Switch and unplug the printer from the power receptacle.
2. Unplug the power cable from the printer.
3. Remove all media from the printer, to expose the Feed Rollers [A].
4. Follow the procedures under “Removing Jammed Media” to remove the “Antistatic Brush Assembly” [C]. This will provide access to the black rubber “Forwarding Rollers” [B].
5. Use a vacuum with a soft brush attachment to help loosen and remove dust particles from these areas.
6. Dampen a cloth with a mild household cleaner, which does not contain plastic or rubber harming solvents, and wipe-down the rubber rollers to remove debris.
CAUTION: Be careful not to drip any liquids into the sensors or electronics.
7. Reinstall the “Antistatic Brush Assembly”.
CAUTION: Verify that the ink tubes are not pinched by the fingers on the Antistatic Brush Assembly.
8. Reconnect the power cord and Turn ON the Main Power Switch. Then press the ON/OFF button on control panel to power-up the Print Engine.

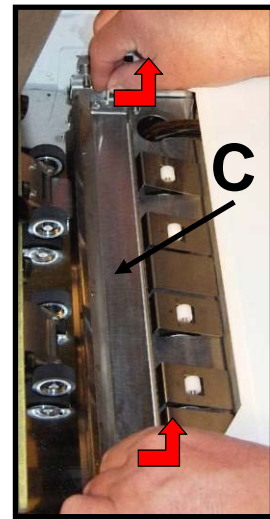
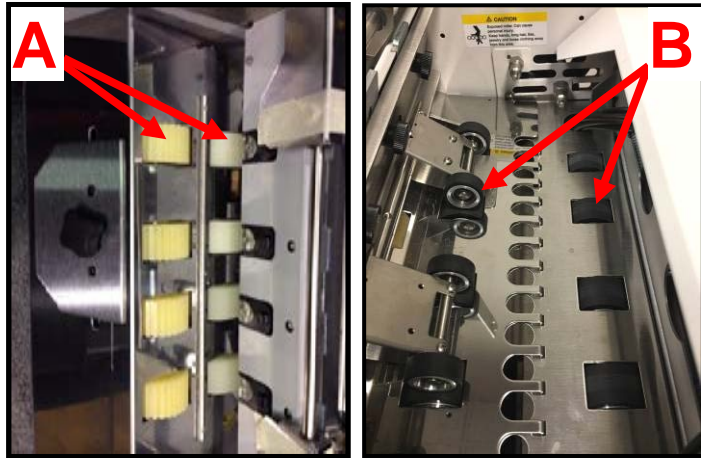

Cleaning the Feed Sensor

The Feed Sensor is located between the media hopper and the print engine. It has several functions.

- It is used to control the delivery of media to the print engine.
- It is used to monitor the piece length.
- It drives the LCD counter, located on the entrance side of the printer.

TIP: If the LCD counter is not incrementing with each piece of media, then the sensor is not working properly (dusty/dirty). This can be intermittent. If in doubt, clean the sensor.

NOTICE: If you are uncomfortable performing this task, or this issue is not resolved by cleaning the sensor, please contact your support representative.

1. If the printer is on, press the ON/OFF button to power-down the print engine. Wait about 45 seconds until the system shuts down (all control panel lights will go off). Turn off the Main Power Switch and unplug the printer from the power receptacle.
WARNING! If this power-down process is not followed, ink color mixing and printhead nozzle clogging may result.

2. Unplug the power cable from the printer.

3. Remove the Antistatic Brush Assembly [A]

4. Place a piece of paper into this area, as shown in images below, to catch any screws that you might drop during this process.

5. Remove the two Philips head screws, as shown.

Note: Newer units have Thumb Screws instead of Philips head screws.

6. Remove the reflector plate.

Note: There is a reflector attached to the underside of this plate. Please be sure to inspect/clean the reflector.

7. You can now access this sensor through the hole in the table-top.

8. Clean the Feed Sensor using compressed air and a soft brush or soft cotton swab.

9. Re-assemble in reverse order.

CAUTION: Verify that the ink tubes are not pinched by the fingers on the Antistatic Brush Assembly.

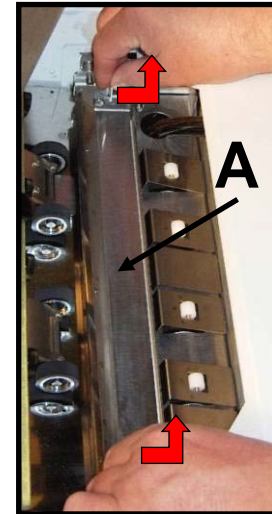

Cleaning Other Items inside the Print Engine

Areas in the Print Engine can become glazed with a buildup of dust, paper lint and accumulated ink and need to be cleaned regularly.

This section covers the procedures for cleaning the following items.

Grit Rollers (Media Transport Rollers)

Media (Paperpath) Sensors

Capping Station Lip

Paperpath Surfaces

Printing Platen Surface

WARNING

THE PRINTER IS A PRECISION MACHINE THAT SHOULD BE CLEANED REGULARLY TO INSURE MANY YEARS OF SERVICE. BEFORE PERFORMING ANY MAINTENANCE, DISCONNECT THE MACHINE FROM ITS POWER SOURCE! DO NOT REMOVE SIDE COVERS! HIGH VOLTAGES PRESENT.

NOTICE: If you are uncomfortable performing these tasks, or this issue is not resolved by cleaning, please contact your support representative.

Procedure:

1. If the printer is on, press the ON/OFF button to power-down the print engine. Wait about 45 seconds until the system shuts down (all control panel lights will go off).
2. Turn off the Main Power Switch and unplug the printer from the power receptacle.
3. Open the Top Cover and then carefully open the Clamshell Assembly.
4. Use a vacuum to pick up any loose debris.
NOTE: Be careful around ink tray and capping station in the Print Engine area as accumulated ink may splash onto other parts of the printer. Take care not to damage the PC Boards or electrical wiring.
The use of compressed air is not recommended. If you direct the air into an area with wet ink, ink will splash onto other parts of the printer, which could affect operation.

CAUTION

USE ONLY DEIONIZED/DISTILLED WATER TO CLEAN PRINT ENGINE COMPONENTS. AVOID CONTAMINATING THE PRINTHEAD WITH CLEANERS, LUBRICANTS OR OTHER CHEMICALS.

- Use the procedures, as outlined below, to clean the following items.

Grit Rollers [A]:

Clean as needed using a small stiff-bristled brush (toothbrush), lightly moistened with distilled water.

Do NOT use anything other than distilled water to clean the Rollers.

Pat the roller dry using a lint-free cloth. Do NOT rub with cloth or this may produce lint.

Media (Paperpath) Sensors [B]:

Paper lint, dust and ink will build-up on the Media Sensors. Be sure to clean the Paperpath Entry, Paperpath Exit and Mark sensors routinely.

Use a lightly dampened foam, or lint-free, cotton swab to gently wipe the Sensors. Repeat this process until all ink/debris is removed. Take care not to drip water into the circuit boards.

Use a clean, dry swab to dab surfaces dry.

Remember to wipe the clear panel, on the Sensor Receiver, which is located in the upper Clamshell Assembly (above the Paperpath Entry Sensor).

Note: Even though the “Mark Sensor” is not used to identify the leading edge of the media, in the MACH 5 printer, the printer’s logic still needs to see a signal from this item.

Capping Station Lip [C]:

Clean as needed with distilled water on a damp, lint-free, cloth. Try to avoid contact with the “wicking material” located in the center of the Capping Station.

Be careful not to splash or drip ink onto other parts of the Printer.

Paperpath Surfaces [D]:

Wipe with distilled water on a damp, lint-free cloth. Pat dry with a lint-free cloth.

- Reconnect the power cord to the printer and turn the Main Power switch ON.
- Make sure your hands/clothes/leaning supplies are clear from the print engine, then Power-up the print engine using the ON/OFF button.
After a short period of time, the Capping Station will drop, and the Printing Platen will be presented through the same opening. Carefully clean the Printing Platen as described below.

Printing Platen Surface [E]:

Clean the surface as needed with distilled water on a damp, lint-free, cloth. Try to avoid contact with the “wicking material” located in the center of the Platen.

- Carefully close and Latch the “Clamshell”, using two hands.

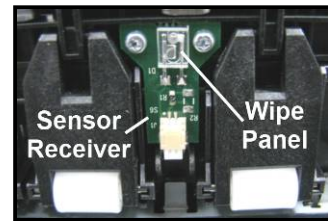
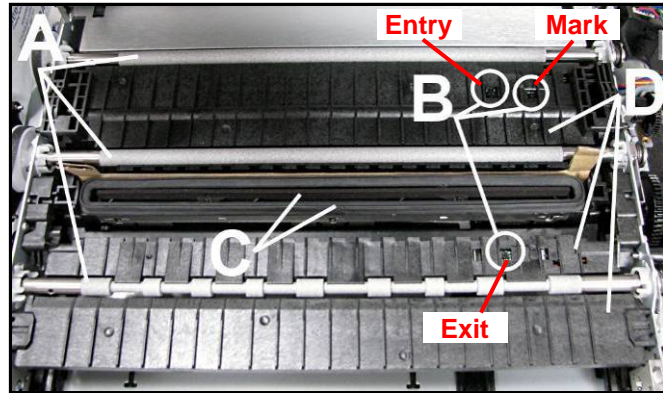

Cleaning the Ink Revolver Couplings

This process should be performed just before a printhead cartridge is installed or re-installed, to remove contaminated/dry ink and other debris from the Ink Revolver Couplings. If this step is skipped, the printhead and or ink system could become contaminated resulting in an increase in print quality issues.

1. If Printhead Cartridge is installed, follow the procedure for releasing and removing the Printhead Cartridge. See section titled “Replacing the Printhead Cartridge”.
2. If the printer is on, press the ON/OFF button to power-down the print engine. Wait about 45 seconds until the system shuts down (all control panel lights will go off). Turn off the Main Power Switch and unplug the printer from the power receptacle.
3. Lightly moisten a foam swab with distilled water.
4. Insert the swab into one of the ink channel holes and rotate the swab to clean the chamber.
5. Use a new swab for each of the remaining ink channels, until all 10 openings are clean. (*5 on each side.*)
6. Install the Printhead as described in the section titled “Installing the Printhead Cartridge”.

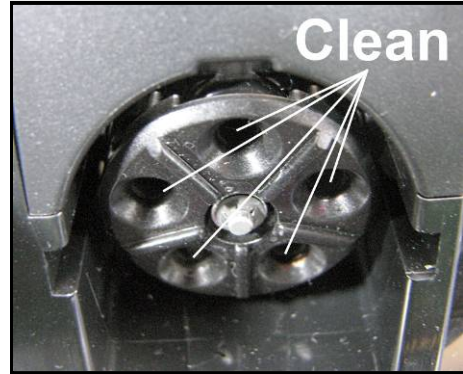

Printer Maintenance Schedule

General, periodic maintenance is needed to keep the Printer in good working order. Many tasks can be performed by operators with basic supplies, no special tools needed. Other tasks should only be performed by trained service personnel. **NOTE:** High volume usage may require more frequent maintenance.

COMPONENTS / TASKS	MAINTENANCE TYPE				
	DAILY	BI-WEEKLY	MONTHLY	YEARLY	AS NEEDED
PERFORMED BY OPERATOR					
Rubber Feed Rollers		CLEAN	CLEAN	CLEAN	CLEAN
Grit Rollers (Media Path)			INSPECT	CLEAN	CLEAN
Ink Revolver Couplings and Connections: Inspection/Cleaning					EVERY PRINTHEAD REMOVAL
Ink Tank Contacts & Prism (Clean)					EVERY INK TANK INSTALL
Optical Sensors (Media Feed & Paperpath)	CLEAN	CLEAN	CLEAN	CLEAN	CLEAN
Printhead (Manual Wiping)					WIPE
Printhead, Head Media Guide & Lip of Capping Station (Manual Wiping)					AFTER EVERY PRINTHEAD INSTALL
Residue and Debris Removal	CLEAN	CLEAN	CLEAN	CLEAN	CLEAN
Sheet Separators			INSPECT	INSPECT	REPLACE
Wiper Roller: Inspection		INSPECT	INSPECT	INSPECT	Contact Service to Replace
Waste Ink Tray			INSPECT	INSPECT	REPLACE
PERFORMED BY SERVICE TECHNICIAN					
Ink Tank Latches/Ink Bay				INSPECT	
Ink Tubing, Couplings, Components				INSPECT	
Lubrication (Service Station Rails, Lift Arm Cams, etc..)				APPLY	
Moving Parts/Motors/Gears				INSPECT & TEST	REPLACE
Optical Sensors (Service Station Home, Index and Lift)				INSPECT & TEST	CLEAN
*Pen Driver PCA Contacts: Cleaning				INSPECT & CLEAN	INSPECT/ CLEAN AFTER PRINTHEAD REMOVAL
*Service Station & Components				INSPECT	CLEAN or REPLACE
*Wiper Roller: Replace				INSPECT	EVERY PRINTHEAD REPLACEMENT
Rubber Feed Rollers				INSPECT	REPLACE

* Customer may be able to perform these tasks with proper training.

WARNING

ALWAYS POWER DOWN THE PRINTER BEFORE PERFORMING ANY MAINTENANCE, TO AVOID SERIOUS SHOCK OR INJURY.

Preparing Printer for Transport

Please use this procedure if you ever need to transport the printer to a new location or ship the printer. Please refer to the appropriate sections in the manual for details on installing/removing items from the printer.

Local relocation

Transporting the printer from one room to another in the same building is considered a local relocation. Local relocation does not normally require that the printer be repackaged before transportation. To move your printer locally:

1. Switch the printer off using the ON/OFF button and wait until all lights turn off.
2. Turn off the Main Power Switch. Then disconnect the power cable from the printer and wall outlet.
IMPORTANT! Do NOT switch off the power at the power outlet or remove the power cable until all lights are off. Failure to do so may damage your printer.
3. Disconnect the USB or Ethernet cable from your printer.
4. Two people are required to lift the printer, keeping it as level as possible during this process.
IMPORTANT! The printer should remain semi-level at all times during transportation and storage. Failure to do so may cause the printer to leak ink.
5. Take care to avoid sharp bumps and strong vibrations during the relocation process.
6. Be sure to select an appropriate location, as described in the “Choosing the Location” section.

Remote relocation or shipping

Transporting the printer to another building is considered a remote relocation.

When transporting your printer to a remote location, your printer will need to be disassembled and repackaged, as set out below:

NOTE: This procedure should be performed by a qualified technician. We suggest the use of protective gloves during this process.

1. Plug in the printer. Turn the printer’s Main Power Switch ON, then press the control panel’s ON/OFF button. Wait about 45 seconds for the print engine to power-up (ON/OFF button will illuminate).
2. Open the Toolbox utility.
3. Deprime system using the “**System Deprime**” feature located in Toolbox utility.
NOTE: Use the **System Deprime** feature, NOT the **Release Printhead** feature.
4. Remove the Service Station from the printer, using the “**Eject Service Station**” feature in the Toolbox utility. Refer to “**Removing the Service Station**” section for help with this process.
5. Wrap the Service Station in paper towels and place into resealable plastic bag.
6. Power-down the system using the ON/OFF button and wait until all lights are off.
7. Turn off the Main Power Switch. Then disconnect the power cable from the printer and wall outlet.
IMPORTANT! Do NOT switch off the power at the power outlet or remove the power cable until all lights are off. Failure to do so may damage your printer.
8. Disconnect the USB or Ethernet cable from your printer

9. Remove the Printhead Cartridge and install protective covers on printhead.
Be careful to avoid ink spills (drips) and stains during this process.
Store Printhead Cartridge in a sealed plastic bag with a damp cloth.
CAUTION: Make sure the cartridges electrical contacts are dry before re-installing printhead.
10. Remove all five Ink Tanks. Be careful to avoid spills or stains during this process. Wrap each ink tank in a clean, lint-free, absorbent material and place them in a sealed plastic bag as a precaution against any spillages during transport.
11. Place paper towels into each Ink Tank slot, making sure the towels make contact with the back of the slots. This is done to absorb any ink that may leak from “septum needles”.
NOTE: Even though the system is deprimed, some ink will remain in the lower areas of the tubing. In transit, this residual ink may drain out.
12. Inspect the Waste Ink Tray. If it is saturated with ink, the tray should be replaced before the printer is transported.
13. If re-boxing for transport, remove all accessories (side guides, rear media support guide) from unit before re-boxing.
14. Re-package the printer in the original packaging material, keeping the printer level at all times.
WARNING! To help avoid damage in transit, the printer should only be shipped in approved factory packaging. See “Unpacking” section for help with re-boxing.
Follow the sequence in reverse.
15. Ensure transport labels on the exterior box clearly indicate that the box is to be kept level at all times.
CAUTION! The printer should remain semi-level at all times during transportation and storage. Failure to do so may cause the printer to leak ink. For environmental requirements during storage and shipping, refer to the details found in the “Transport Inspection” section.
16. When re-installing the printer at the new location, please refer to Section 2 (Instilling the Printer) of this guide.

Section 6 – Troubleshooting Guide

The following troubleshooting guides are provided to assist you in solving any problems that might occur with the printer. We have tried to make them as complete as possible. The best advice we can offer is to make sure that the system is set up properly, plugged in, and that it has an adequate supply of ink before attempting to troubleshoot any problem.

WARNING

**DO NOT REMOVE THE SIDE COVERS OF THE PRINTER!
THERE ARE HIGH VOLTAGES PRESENT BEHIND THE COVERS!**

Print Quality Issues:

Many things can contribute to print quality issues. Here is a list of things to check:

- To reduce print quality issues, the print engine should remain powered-on. Even in its standby state, the printer will run routine maintenance cycles to help keep the printhead nozzles hydrated and clean.
- Verify that the media you are printing on is an “inkjet suitable” media. See Paper Types below.
- Verify that the “graphic” you are printing is of a high quality. See Graphic Types below.
- Check to be sure the printer has an adequate supply of ink (30% or more) in all five Ink Tanks.
- Check to be sure all five ink tubes, at both sides of the printhead cartridge, have ink filling them. If not, check for a pinched ink tube (finger on Antistatic Brush Assy may be pinching tube), check related Ink Tank, and or the system may need to be re-primed.
- Try removing air bubbles from printhead and system using the Toolbox utility feature “Circulate Ink”, while lightly tapping on the ink tubes and printhead cartridge.
Note: Do not run the Circulate Ink feature more than twice in a row.
- Try “Cleaning the Lip of the Printhead Cap”.
- Try “Cleaning/Replacing Service Station Items”.
- If printing on envelopes, check that the “Envelope Printing Attachment Kit” is installed.
- If printing on single sheet media, try removing the blue plastic, PPS Spacers from the Printing Platen.
- If you are still experiencing print quality issues, try “Replacing the Printhead Cartridge”.

Compatible Paper Types: (look for inkjet suitable stocks)

- Inkjet Paper - all types (recommended for best color output).
- Copier Paper
- Card Stock
- Kromekote
- Coated Paper - Gloss finish
- Coated Paper - Satin finish
- Coated Paper - Matte finish

Incompatible Paper Types:

- Color Laser Gloss
- Digital Printer Gloss
- Any Post Print Coated Substrate (aqueous, gravure or UV)

Compatible Graphic Types:

- In general, scalable, vectorized art will produce the best images and color.
Note: Graphic types are not really printer dependent. They are dependent on the software program being used to print the graphic, and what types of graphics that program can handle.

Incompatible Graphic Types:

- Low resolution and web images will not produce quality output and should not be used.

Examples of Print Quality Issues (including possible causes and solutions)

The Memjet printhead cartridge contains 70,400 inkjet nozzles. These nozzles are divided into ten rows: two rows of nozzles for each color channel. Due to the extremely high number of nozzles, it is not uncommon for some nozzles to become contaminated, dehydrated or clogged.

The following examples were produced using a Five Band Color Purge YKCKM. A similar purge pattern can be performed using the “Print Ink Channels” button, located in the Toolbox, Print drop-down menu.

Air in Printhead Nozzle Area:

Air in the printhead nozzles will show as jagged, irregular shaped lines of missing color. Lines are normally wider than one nozzle.

Possible Solutions:

- Press the “Full Clean Printhead” button, located in the Toolbox, Maintenance drop-down menu, and lightly tap on the ink tubes and Printhead Cartridge as the system is circulating ink. This can help dislodge air bubbles within the Printhead and Ink Tubes.
Note: It is not a problem if air bubbles accumulate in the ink hoses at the non-operator side of the printhead, since this is the outgoing side.
- Depriime and Reprime the system. Release the Printhead, using the “Release Printhead” button. Remove and re-install the Printhead Cartridge. Then close printhead latch to re-prime the system. Lightly tap on the ink tubes and Printhead Cartridge as the system is priming, to help dislodge air bubbles.
- Contact Service person to have them inspect the system for possible air leaks (damage to ink tubes or ink revolver couplings).
- Instead of powering the printer off, when not in use, leave the print engine powered-up, so it can perform automatic maintenance routines.



SECTION 6 TROUBLESHOOTING

Clogged/Damaged/Dead Nozzles:

Clogged/damaged/dead/ nozzles will normally show as thin, crisp, vertical lines of missing color. Multiple adjacent nozzles, with same issue, will show as wider, crisp, vertical lines of missing color.

Clogged nozzles are normally due to Printhead nozzle dehydration or partial contamination.

Damaged nozzles are normally due to improper cleaning or debris on wiper roller causing damage to head.

Dead nozzles are normally due to the nozzle reaching its “end of life” (~50,000,000 ejections).

Possible Solutions:

- Press the “Full Clean Printhead” button, located in the Toolbox, Maintenance drop-down menu
- Manually clean the printhead nozzles using distilled water and a lint free cloth.
- Set the following Toolbox features to defaults to improve/increase head maintenance routines: KWS Setting (Light) and Mid-Job Servicing (Default).
- Replace the printhead cartridge and wiper roller. Contact Service person to have them inspect/clean the service station and replace the wiper roller.
- Instead of powering the printer off, when not in use, leave the print engine powered-up, so it can perform automatic maintenance routines.

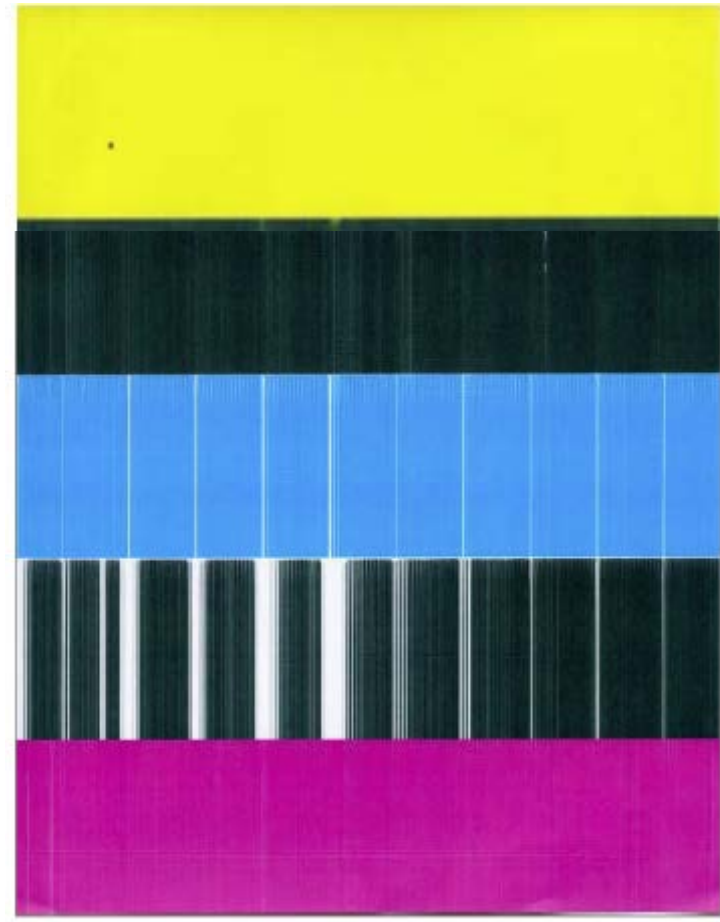

Color Mixing Issues:

Color mixing will show as muddy, mottled, or distorted (grainy) colors.

Color mixing occurs when the ink from one color channel crosses over into another color channel. Since the inkjet nozzle rows are located very close to one another (ten rows of 7,040 nozzles, located within a 0.8 mm space), it is easy for partials or fibers to create bridges across color channels. These bridges allow ink to flow (wick) from one color channel to another, resulting in a “localized” color mixing event, as shown in the examples below.

Color mixing can occur for several reasons (here are some common ones)

- Printhead Cartridge just installed. It is common to see some color mixing immediately after the system is primed with ink.
- Ink wicking due to fibers bridging (crossing) inkjet nozzles. This can also occur if media is left in contact with the printhead (after a paper misfeed or jam).
- Wiper roller over-saturated (too much ink on wiper roller). This can occur if the cleaning features (Quick/Normal/Full Clean Printhead) are run too frequently. The printer needs time between cleanings to desaturate the ink from the wiper roller.
- Wiper roller too dry.
- Ink flooding on the nozzle plate, due to printer not being level.
- Ink flooding on the nozzle plate, due to excessive back-pressure in the ink system.
- Wiper Roller is not being cleaned properly by the system. This can also occur if there is a problem with the squeegee blade in the Wiper Motor Assembly. The squeegee blade and squeegee roller are responsible for removing ink and debris from the wiper roller.

Tip: Muddy, mottled, distorted (grainy) colors can also be caused by the media you are printing onto. Test the printer, using a compatible “inkjet suitable” media, to determine if this could be the cause.

Possible Solutions:

- Remove media from under printhead.
- Wipe printhead using a lint-free cloth, dampened with distilled water.
- Perform a “Printhead Cartridge Conditioning” routine.
- Allow the printer to sit, powered on, for 2-3 hours to give it time to clean/desaturate the wiper roller.
- Run “Wiper Preemptive Maintenance” to hydrate wiper roller.
- Make sure printer is on a sturdy, level table.
- Instead of powering the printer off, when not in use, leave the print engine powered-up, so it can perform automatic maintenance routines. This also allows the pressures in the system to be routinely equalized.
- Contact Service Support representative to have them inspect/clean the service station. If necessary, they may need to replace the wiper roller, wiper motor assembly or Service Station.

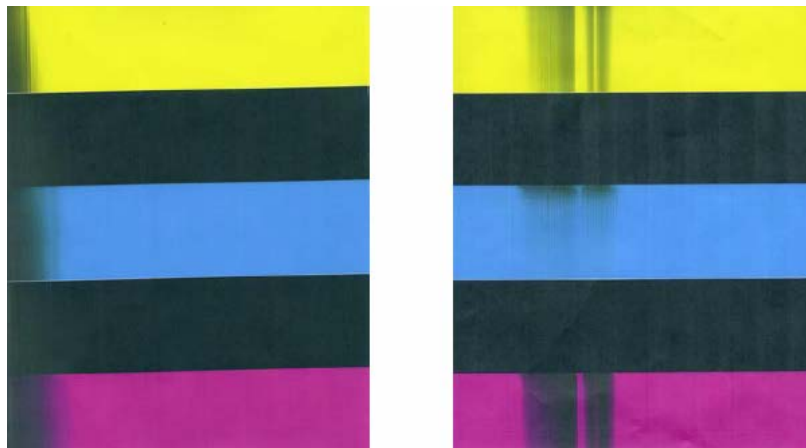

SECTION 6 TROUBLESHOOTING

Scuff Marks and Smudging Issues:

Scuff Marks occur when the media makes contact with an area of the printhead that has ink on it. Smudging occurs when the wet image, on the media, makes contact with something (most commonly the printhead) before it is dry. This issue will also increase the chance for scuff marks.

Scuff Marks:

Here is an example of “scuff marks” that occurred when the high points (thicker/puffier areas) on this #10 envelope made contact with the printhead.

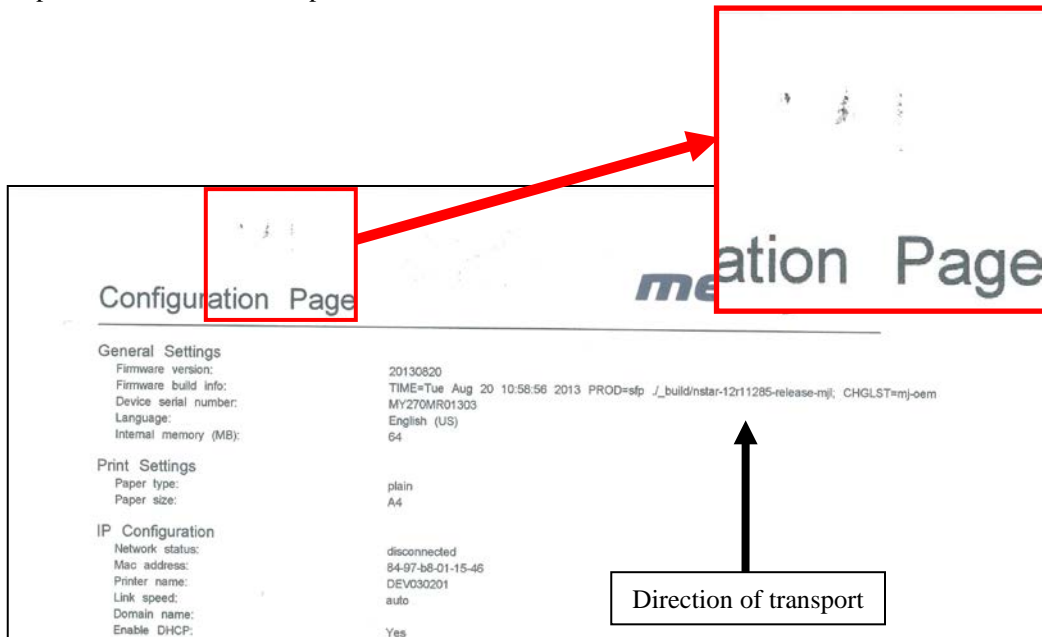

Possible Solutions for Reducing Scuff Marks:

- Make sure the “Head Media Guide” is properly installed.
- Try removing or inserting the “PPS Spacers”.
- Make sure media is as flat as possible and folds are as tight as possible.
- Manually wipe the printhead surface, using a lint-free cloth dampened with distilled water to remove excess ink.
- If possible, rotate the media and image 90, 270 or 180 degrees. Sometimes the direction of feed and the mechanics of how the media is driven through the printer can have an effect.
- Allow the printer to sit, powered on, for 2-3 hours to give it time to remove excess ink from the wiper roller, or contact your support representative to have the wiper roller replaced.
- Use a more suitable media (flat and uniform in thickness).

NOTICE! It is OK to run the “Quick Clean Printhead” routine once, to see if this has any effect on improving this issue. However, if it doesn’t help, you shouldn’t repeat this process or use a higher-level cleaning routine. Over-use of the “...Clean Printhead” routines will normally increase this issue, because the wiper roller will become more saturated with ink with each cleaning routine, if done too frequently. An over-saturated wiper roller will leave more ink behind on the printhead.

Smudging:

Here is an example of “smudging” that occurred when an area of this page, with a wet image, made contact with the printhead.

Note: There are also scuff marks in this example. As mentioned previously, smudging will increase the chance for scuff marks, by deposition ink onto other areas of the printhead.

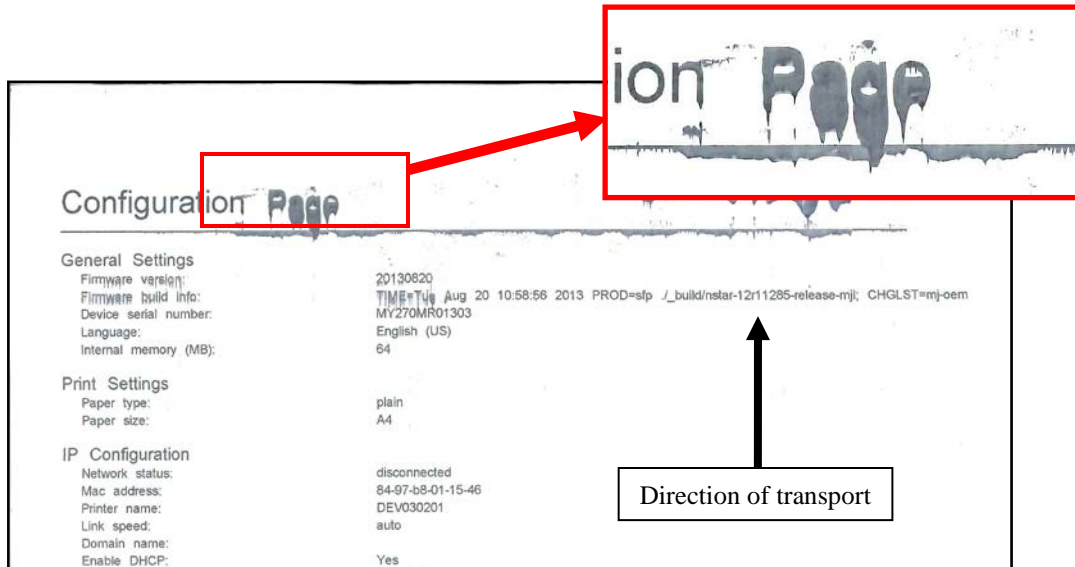

Possible Solutions to Reduce Smudging:

- Check to be sure the “Head Media Guide” is properly installed and clean.
- Try removing or inserting the “PPS Spacers”.
- Make sure media is as flat as possible and folds are as tight as possible.
- If possible, rotate the media and image 90, 270 or 180 degrees. Sometimes the direction of feed and the mechanics of how the media is driven through the printer can have an effect.
- Reduce the amount of ink being sprayed onto the media by setting the print quality to “Normal”. Spraying less ink will improve the drying time.
- Reduce the print speed to provide more drying time. If you are already printing in Normal Print Quality, you can select (check) the “half speed” box, located under the Print Quality selection in the M Series Driver.
- Use a more inkjet suitable media.

NOTICE! It is OK to run the “Quick Clean Printhead” routine once, to see if this has any effect on improving this issue. However, if it doesn’t help, you shouldn’t repeat this process or use a higher-level cleaning routine. Over-use of the “...Clean Printhead” routines will normally increase this issue, because the wiper roller will become more saturated with ink with each cleaning routine, if done too frequently. An over-saturated wiper roller will leave more ink behind on the printhead.

Fuzzy/Distorted Print

Fuzzy/distorted print can occur for several reasons, listed/shown below.

Problem: Poor original image quality (less than 300 dpi).

Solution: Use high quality images.

Problem: Choosing to print image in low resolution from software application.

Solution: Set image to highest resolution possible from software application.

Problem: Paper is buckling or bowing during the time of printing.

Solution: Try removing the PPS spacers. Try printing on a thicker piece of media (i.e., 40lb paper) If problem does not occur on heavier material the media you are feeding may be too flimsy.

Problem: Damaged Printhead nozzle surface, scratched from improper manual cleaning, or dirty/damaged wiper roller.

Solution: Only use distilled water and a non-abrasive, lint free cloth to manually clean the printhead.

Replace the wiper roller at the same time the printhead is replaced. Cover the printer, when not in use, to keep dust/debris (plaster dust) from entering the printer.

Fuzz/Distorted Print Example:

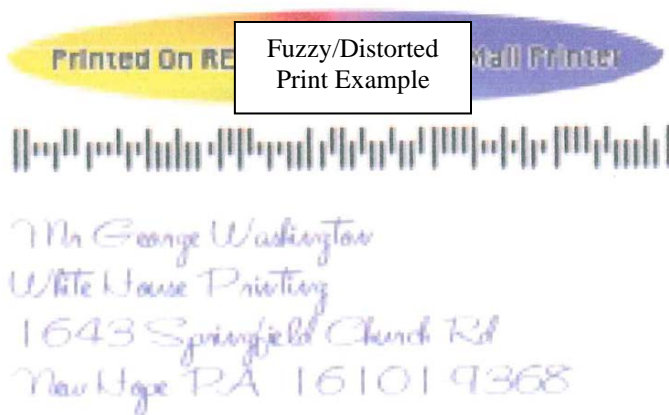

Good Print Example:



The Ink Tank(s)

Notice: To avoid problems caused by an Ink Channel (ink tube) running dry, the Ink Tank will be flagged as “Ink Out” before it is totally dry. Therefore, it is common for a small amount of ink to be left within the Ink Tank when the “Ink Out” condition is reached.

CONDITION	PROBLEM	SOLUTION
<p>Installed New Ink Tank and shortly after the related Ink Channel (color) stopped printing and or the related color tube went empty.</p> <p>CAUTION! Do NOT continue printing in this condition. Damage to the Printhead will result.</p>	<p>One or more of the “septum needles” didn’t fully puncture the septum seals on the new Ink Tank.</p> <p>Antistatic Brush Assembly was not installed properly.</p> <p>Defective Ink Tank.</p>	<p>Try removing and re-installing the Tank. See “Installing The Ink Tanks”.</p> <p>Is the Antistatic Brush Assembly pinching tubes?</p> <p>Replace defective Ink Tank. Please contact your support representative to report issue.</p>
<p>Ink Level status is displayed as “Out” or “0%” but there is still plenty of ink in the Tank.</p> <p>Toolbox System Status is displaying “Ink_Out_X” (X = color or multiple)</p>	<p>Visible ink level sensor does not see the presence of ink in the Tank.</p> <p>Printer is not on a stable, level surface, causing ink level sensor to give a premature “Out” condition.</p> <p>QA Chip on Tank may have been corrupted, due to improper removal/install.</p>	<p>Clean prism on Tank. See section titled “Cleaning Ink Tank Contacts & Prism”.</p> <p>Place printer on stable, level surface.</p> <p>Replace Ink Tank. Please see section titled “Replacing the Ink Tanks”.</p>
<p>Ink Level status was displaying 5% or more and then it suddenly changed to “Out” or “0%”.</p> <p>Toolbox System Status is displaying “Ink_Out_X” (X = color or multiple)</p>	<p>Visible ink level sensor does not see the presence of ink in the Tank.</p> <p>Printer is not on a stable, level surface, causing ink level sensor to give premature “Out” condition.</p> <p>Tank is Empty.</p> <p>Under-estimation of Ink Usage.</p> <p>System has calculated that 250 ml of ink has been used from this Tank.</p>	<p>Clean prism on Tank. See section titled “Cleaning Ink Tank Contacts & Prism”.</p> <p>Place printer on stable, level surface.</p> <p>Replace Ink Tank.</p> <p>NOTE: Although the system is very good at estimating ink usage, it will never be perfect. To help improve Ink Level estimation accuracy, make sure the firmware is up-to-date and try to minimize depriming and repriming system.</p>
<p>Ink Level status is displayed as “?”.</p> <p>Toolbox System Status is displaying “Tank_Missing_X” (X = color or multiple)</p>	<p>Poor connection between QA Chip contacts and printer.</p> <p>Un-authorized Ink Tank installed.</p> <p>QA Chip on Tank may have been corrupted, due to improper removal/install.</p>	<p>Clean contacts. See section titled “Cleaning Ink Tank Contacts & Prism”.</p> <p>Purchase/install Authorized Tank.</p> <p>Replace Ink Tank. Please see section titled “Replacing the Ink Tanks”.</p>

**SECTION 6
TROUBLESHOOTING**

The Printhead Cartridge

The Memjet printhead cartridge contains over 70,000 inkjet nozzles. These nozzles are divided into ten rows: two rows of nozzles for each color channel. Due to the very tiny size of each nozzle and the high number of nozzles, it is not uncommon for some nozzles to become contaminated or clogged.

CONDITION	PROBLEM	SOLUTION
Mixed, mottled, muddy or distorted colors.	<p>Ink color channel mixing within the printhead cartridge/nozzles. Over-saturated wiper roller.</p> <p>Wiper roller too dry.</p> <p>Incompatible media. Table is not level.</p> <p>Printer was not powered-down properly. Printhead may not have been cleaned or capped. Ink system may not have been stabilized.</p>	<p>Refer to “Printhead Cartridge Conditioning”. If problem persists, refer to section titled “Color Mixing Issues”.</p> <p>Run Wiper Preemptive Maintenance.</p> <p>Use inkjet suitable media</p> <p>Make sure table, that printer is placed on, is level.</p> <p>Make sure to power-down the printer using the ON/OFF button, before shutting off the Main Power Switch.</p>
Thin, crisp vertical line(s) of missing color.	<p>Clogged printhead nozzle(s). Electrical failure or poor electrical connection at printhead.</p>	<p>Clean the Printhead</p> <p>Reseat the Printhead.</p> <p>Replace the Printhead & wiper roller.</p>
Irregular or Jagged vertical line(s) of missing color.	<p>Air in the system. Air bubbles blocking nozzle(s).</p>	<p>Refer to “Printhead Cartridge Conditioning”.</p>
Black scuff marks on media or image smudging occurs.	<p>Media is making contact with the printhead surface.</p>	<p>Install the Head Media Guide.</p> <p>Try adding/removing PPS spacers.</p> <p>Run the media in a different orientation.</p> <p>Use media that is not bent, bowed, or buckled.</p>
Blurry/Grainy Images	<p>Partially clogged nozzle(s). Incompatible media. Low quality image being sent to printer.</p> <p>Damaged/scratched nozzle surface.</p>	<p>Clean the Printhead</p> <p>Use inkjet suitable media.</p> <p>Use high quality graphics that are compatible with your software program.</p> <p>Replace the Printhead & wiper roller.</p>



**The ink used in this system may be harmful if swallowed.
Keep new and used printhead cartridges and ink tanks out of reach of children.
Discard unwanted printhead cartridges and empty ink tanks immediately.**

The Printhead Cartridge (continued)

CONDITION	PROBLEM	SOLUTION
<p>System will not prime the printhead after installing Printhead Cartridge</p> <p>During the priming process one or more of the ink color tubes are not filling with ink.</p>	<p>Printhead nozzles dry (air pulled through nozzles, not allowing system to create vacuum)</p> <p>Capping station not making good seal against the printhead.</p> <p>Pinched/kinked ink tube(s)</p> <p>Ink Tanks may not have enough ink in them to prime system.</p> <p>Ink Tank Issue</p> <p>Toolbox displays ...Low_Ink or Ink_Out... message.</p> <p>Toolbox displays Ink_Error</p> <p>Printhead ink channel(s) are clogged</p> <p>Toolbox displays Ink Valve Error.</p> <p>Damaged Ink Coupling (revolver)</p>	<p>Wet the Printhead nozzles using distilled water and a wet, lint-free cloth.</p> <p>Check for obstruction. Is the Head Media Guide in the way? Try removing it.</p> <p>Check ink tubes. Is the Antistatic Brush Assy pinching tubes?</p> <p>Replace Ink Tank(s).</p> <p>Replace the Printhead.</p> <p>Contact Service Support.</p>
<p>Ink leaking from the printhead nozzles</p>	<p>Table is not level.</p> <p>Excessive back-pressure within ink system, caused by print engine being powered-down when not in use.</p> <p>Wicking material, inside capping station, is making contact with the printhead nozzles.</p> <p>Opening in ink system, allowing loss of vacuum.</p>	<p>Manually clean printhead.</p> <p>Make sure table, that printer is placed on, is sturdy and level.</p> <p>Allow print engine to remain powered-up, when not in use, so it can routinely cycle the pinch valve to equalize back-pressure in the system.</p> <p>Replace the capping station or the entire service station.</p> <p>Install missing Ink Tanks.</p> <p>Verify that Ink Tank Latches are fully closed and locked.</p> <p>Clean Ink Couplings.</p> <p>Verify that Printhead Latch is fully closed and locked.</p> <p>Contact Service Support.</p>

The Printer

NOTICE: The printer will not print if any of the five ink tanks are empty or missing.

Dots or Lines Printed on Media

CONDITION	PROBLEM	SOLUTION
Multiple horizontal black lines are printed down the length of the media.	You have exceeded the maximum print width of 8.5”.	Reduce paper width to 8.5” to avoid exceeding the max print width of printer. NOTE: This symptom only occurs with older firmware. Contact Service Support to update the printer’s firmware.
A thick horizontal black line is printed at or near the trailing edge of the media.	Purge Bar is hitting trailing edge of media. Media is hesitating or skewing during transport. Hole in media is passing over the Paperpath Entry sensor. Media is oddly shaped (running media with open flap at trailing edge).	To help keep nozzles from drying (clogging), all nozzles of the printhead are purged, between each page. Check/adjust media feed setup. Check for proper install of Antistatic Brush Assembly. Check for obstruction within the Print Engine. Rotate media and image so hole in media does not travel over the Paperpath Sensors. Adjust the “Purge Bar Position” value, located in the User Interface Menu of the Toolbox. Default = 3000. If you don’t see this feature in the User Interface Menu, please contact service support and ask them to update the firmware. Use compatible media.
Very small dots (gray overspray) are being printed down length of media.	These dots are formed by interpage nozzle spitting. Controlled by the KWS (Keep Wet System) setting.	Interpage (on the page) nozzle spitting is normal. This feature is used to help keep nozzles from drying/clogging. The “KWS Setting” can be used to adjust the Level of spitting. If you don’t see this feature in the User Interface Menu, please contact service support and ask them to update the firmware.

Power Problems

CONDITION	PROBLEM	SOLUTION
Main Power Switch is ON, but the ON/OFF button does not illuminate.	No power being delivered to printer or print engine not powered-on.	Check that the power cord is plugged in. Check that the wall power outlet is live. Check that Main Power Switch is turned ON. Press the ON/OFF button and wait 45 seconds.
	ON/OFF button pressed more than once.	After pressing the ON/OFF button it takes about 45 seconds for the print engine to power-up and the lights to illuminate.
	Problem within printer.	Disconnect Power Cord and check Fuse in Receptacle. Contact Service Support.

Service Station Problems

WARNING! Many of the issues related to Service Station function will require a qualified Service Person, or properly trained person, to diagnose and fix these issues. If you haven't been properly trained or don't feel comfortable performing these procedures, please contact your Service Support Representative.

CONDITION	PROBLEM	SOLUTION
Service Station Drive Motor stalls.	<p>Service Station was not installed properly.</p> <p>Wiper roller securing latches are not closed, preventing Service Station sled from moving properly.</p> <p>Damaged Service Station</p> <p>Jammed gear train due to broken post or improperly seated gears.</p> <p>Damaged Motor</p>	<p>Eject Service Station. Cycle print engine off/on. If drive motor turns without stalling, then motor is OK. If you have trouble ejecting the Service Station, call Service Support.</p> <p>Before re-installing Service Station, make sure: wiper roller latches are closed and not damaged.</p> <p>Replace Service Station.</p> <p>Call Service Support.</p>
Wiper Motor doesn't turn or stalls	<p>Cable not connected.</p> <p>Squeegee blade wedged, not seated properly.</p> <p>Debris build-up on blade and rollers, increasing friction.</p> <p>Bad wiper roller motor</p>	<p>Verify ribbon cable and motor cable are properly connected to board on side of Service Station.</p> <p>Reseat squeegee blade.</p> <p>Clean rollers and blade.</p> <p>Replace Wiper Motor Assembly or Service Station.</p>
Color mixing occurs after wiper roller performs a cleaning	<p>Wiper Roller is over-saturated.</p> <p>Squeegee blade is not seated properly, damaged or bowed.</p>	<p>Allow printer to sit, powered ON, for 2-3 hours or replace wiper roller.</p> <p>Reseat wiper roller squeegee blade. If squeegee blade is damaged/bowed, replace component or Service Station.</p>
Service Station cannot be manually removed from the Print Engine	<p>Wiper Roller Latches were not completely closed when the Station was installed. Latches now hooked on bottom of paper path.</p> <p>Service Station was manually installed too far with Lifting Arms up. Damaged Lifting Arms</p>	<p>Carefully unhook Latches from bottom of paper path and secure latches.</p> <p>If wiper roller latches are damaged, replace Wiper Motor Assembly or Service Station.</p> <p>Call Service Support.</p>

Interface Communication Problems

CONDITION	PROBLEM	SOLUTION
<p>M Series Driver does not respond to printer being connected via USB.</p> <p>Driver shows printer off-line, even with printer connected and powered-up.</p>	<p>Wrong USB port selected in “M Series Driver”.</p> <p>More than one copy of the “M Series Driver” is present and the wrong one was selected.</p> <p>System is hung-up.</p> <p>USB Port, or Cable Connection problem</p>	<p>Verify that you are selecting the appropriate USB port in the driver Ports Tab. Note: During driver install the USB port was automatically assigned. However if someone changes the port setting in the driver you will need to manually reassign the port.</p> <p>If a second M Series Driver was loaded, be sure to select the appropriate one as your default.</p> <p>Clear spooler, and then reboot printer/computer.</p> <p>Test using known good USB cable, replace cable if necessary. If still no communication, check printer using another known good system (computer, software, cable).</p>
<p>No communication with Toolbox utility.</p>	<p>Computer system does not meet minimum requirements.</p> <p>Microsoft .NET Framework not installed, or version not supported.</p> <p>Printer’s Toolbox (Embedded Web Server) not responding.</p> <p>Firewall is blocking communication with Toolbox.</p> <p>System is hung-up.</p> <p>USB Cable connection issue.</p>	<p>Check that computer system meets minimum requirements.</p> <p>Install Microsoft .NET Framework 3.5 (32 bit) or 4 (64 bit).</p> <p>Close and reopen Toolbox utility.</p> <p>Change firewall settings to allow access.</p> <p>Reboot printer/computer.</p> <p>Check/replace USB cable.</p>
<p>Job is sent, but printer does not feed or print.</p>	<p>Printer not connected to computer.</p> <p>Printer Error</p> <p>Media Sensor is covered in Print Engine.</p> <p>Improper Driver Config.</p> <p>System is hung-up.</p> <p>Incorrect settings for wiper & pump motors.</p>	<p>Connect printer cable to computer and resend job.</p> <p>Open Toolbox utility to view errors.</p> <p>Open clamshell and remove media.</p> <p>Uninstall, Re-install Driver.</p> <p>Reboot printer/computer.</p> <p>Call Service Support</p>
<p>Erratic output printing garbage, feeding blanks, etc.</p>	<p>Problem with software</p> <p>Improper driver selected.</p> <p>System was disrupted by static energy.</p>	<p>Test from another software program. Contact software vendor.</p> <p>Use M Series Driver</p> <p>Reboot printer/computer.</p>

Feeding Problems

CONDITION	PROBLEM	SOLUTION
Intermittent feeding	Media Support Wedge not used. Side Guides set too tight to media. Dirty Feed Rollers. Paper stuck together. Uneven mail piece.	The Media Support Wedge adds a slope to the stack and helps feeding. Readjust Side Guides. Clean the Feed Roller with distilled water and a cloth. Do NOT use any solvents as they may damage Rollers. Fan media before placing it in Printer. Tap inserts to front of envelopes and retry.
Multiple feeds (double feeding)	Separator gap not set properly. Media stuck together.	Adjust Separators to thickness of media. Fan the media before loading in Printer.
Failure to feed	Side Guides set too tight to media. No power to Printer. Feed gap too tight. Feed gap too loose. Material is out of specification. Motor on, Feed rollers not turning. Clutch not engaging (forwarding rollers turning, but paper feed rollers not turning) Motor not driving No power.	Readjust Side Guides. Check that power is ON (Main Power Switch and ON/OFF button) and that the power cord is plugged in. Adjust Separator to thickness of media. Maximum thickness is 0.020". Check/Clean Paper Sensors. If problem persists, call Service Support. Call Service Support See Power Problems in this Section.
Jams	Paper path obstruction. Paper not loaded properly. Media Support Wedge not adjusted properly. Separators improperly adjusted. Media curled or bent. The Separators are worn. Paperpath Exit sensor is having trouble seeing the underside of the media (non-reflective colors). Feed Encoder dirty / misadjusted.	Clear jam and remove pieces remaining in print engine. Load media as instructed in manual. Adjust Media Support Wedge. Adjust Separators to thickness of media. Uncurl media. Replace Separator tips. In Toolbox, select (check) "Ignore Exit Sensor". Call Service Support
Right edge of media being damaged as it travels through print engine area	Media is hitting the limits inside the print engine.	Make sure Adjustable Media Side Guide is at least 1/8" away from side frame. If stock is over 9.5" wide, you need to use narrower stock.
Blank piece(s) fed at end of job and or last piece does not exit the Print Engine.	Toolbox "Cutsheet Feeding Mode" is set to Max Throughput. Feed Sensor is dirty/dusty.	In the Max Throughput mode, the printer will feed 1 or 2 blanks at end of job. Set to "Safe Feed" to eliminate this issue. Clean Feed Sensor

Errors and Warnings

Printer Alert Window Messages

Messages sent from the driver and displayed on PC screen in a small popup window.

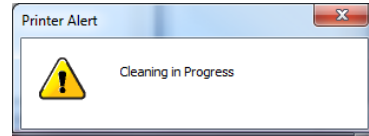

MESSAGE	SOLUTION
Cleaning in Progress	Wait until the message disappears. The printer will start printing your job once the cleaning process has completed.
Incompatible Printhead	Remove and re-insert your printhead cartridge. Replace printhead. Printhead cartridges must be purchased from authorized supplier for this printer model.
Incorrect ... Ink Tank	Replace Ink Tank. Ink Tanks must be purchased from authorized supplier for this printer model.
.... Ink Low Example: Black Ink Low	Reorder Ink
.... Out of Ink Example: Cyan Ink Out	Replace empty Ink Tank
Load Paper	Out of Paper. Load paper into printer and press the PAPER/RESUME button.
Mechanical Jam	Check for and remove obstruction, then press PAPER/RESUME button. Check/Clean sensors. If problem persists, contact technical support.
Missing Printhead	Remove printhead cartridge. Check/clean electrical contacts. Reinsert printhead. Replace printhead. If problem persists, contact technical support.
Multiple Inks Low	Reorder Ink
Multiple Ink Tanks Out	Replace empty Ink Tanks
Multiple Ink Tanks are missing	Insert missing Ink Tanks. Clean electrical contacts and re-seat Ink Tanks.
Multiple Unauthorized Ink Tanks	Remove and re-insert Ink Tank. Replace Ink Tank. Ink Tanks must be purchased from authorized supplier for this printer model.
Paper Jam	Remove jammed media. Check for proper feed setup, then press PAPER/RESUME button. Check/Clean sensors. If problem persists, contact technical support.
Printhead Latch Open	Ensure printhead cartridge has been inserted properly then closer the printhead latch so it locks.
Print Zone Assembly (Clamshell) Open	Check to be sure the Clamshell is completely closed and latched. Make sure Print Engine Latches are secure.
The ... Ink Tank is missing	Insert missing Ink Tank. Clean electrical contacts and re-seat Ink Tank.
Unauthorized ... Ink Tank Installed	Ink Tanks must be purchased from authorized supplier for this printer model.
Unauthorized Printhead	Printhead cartridges must be purchased from authorized supplier for this printer model.

Toolbox System Status Messages

Use the **Toolbox System Status** screen to quickly determine and locate a problem in the Printers.

Status Indicator ERROR shows in the red box.

Printer Graphic Icon highlights which area of the Printer and system is affected.

System Status information on the right displays the basic problem (*in red*).

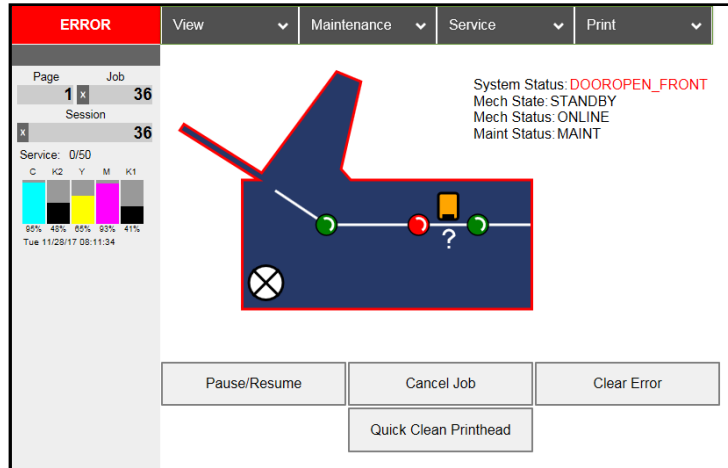

Valid for printers with **firmware version R15 201712**19 or higher installed.

SYSTEM STATUS	PROBLEM	SOLUTION
PAPERPATH_FEED_TIME OUT	Out of Paper Media is not reaching the print engine. Hesitation in media feed.	Load media into printer and press the PAPER/RESUME button. If media is present, check/adjust the guides and separators. Tip: It is also possible to get this error if the media jams after reaching the Paperpath Exit sensor, and the trailing edge is still in the Entry sensor. See below.
	Possible Paper Jam, if error is shown in combination with "Reason: Uncapped printhead or clamshell open" message.	System Status: PAPERPATH_FEED_TIMEOUT Mech State: STANDBY Mech Status: PAPERPATH_FEED_TIMEOUT Maint Status: MAINT Reason: Uncapped printhead or clamshell open
	Problem with Paperpath Entry Sensor or paper sensor in feed section.	See "Paperpath_Paperjam" solutions. Check/clean sensors. Call for service.
	Purge Bar Position (BoF) is exceeding gap between pieces and confusing printer.	Reduce purge bar position setting. Should be set, so it purges, 3mm past edge of media. Check value in Toolbox and Driver. Values are cumulative.

**SECTION 6
TROUBLESHOOTING**

Toolbox System Status Messages (continued)

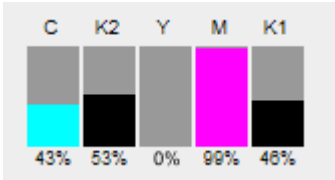
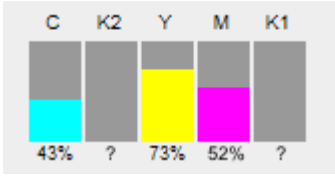
SYSTEM STATUS	PROBLEM	SOLUTION
<p>PAPERPATH_PAPERJAM</p> <p>Paperpath: Entry: Yes Exit: Yes or Paperpath: Entry: No Exit: Yes or Paperpath: Entry: Yes Exit: No</p> <p>No = not blocked Yes = blocked (interrupted)</p>	<p>Paper Jam Media jam detected.</p> <p>Printer has detected that one of the media sensors is blocked (interrupted).</p>	<p>Carefully open the Clamshell, remove jammed Media from printer and close the Clamshell. The System Status message in red should go away.</p> <p>The toolbox “Paperpath” line should change to: Paperpath: Entry: No Exit: No If not, sensors may need to be cleaned.</p> <p>After you clear the jam, you can: Press RESUME button to continue printing. Press the CANCEL button to cancel the job, and then manually clear the job from the computer’s print queue.</p>
<p>PAPERPATH_PAGE_SEQUENCE</p>	<p>Paper length change detected.</p> <p>Paper density change detected. In this case the error may change to Paperpath_Paperjam shortly after detection.</p>	<p>Check/clean the “Feed Sensor”. Check/set sheet separation.</p> <p>If using envelopes or media with varying density, please be sure that the Toolbox feature “Overlap Detection” is unchecked (off). Check/clean Paperpath Entry sensor.</p>
<p>X_INK_LOW</p> <p>Example: CYAN_INK_LOW</p>	<p>X = Color. One or more Ink Tanks are low on ink.</p>	<p>Ink Tank replacement will be necessary soon. Reorder Ink</p>
<p>INK_OUT_X</p> <p>Example: INK_OUT_YELLOW</p> 	<p>X = Color or MULTI One or more Ink Tanks are out of ink</p> <p>NOTE: If the message “INK_OUT_ANY” is displayed, please contact service support, and ask them to update the printer’s firmware.</p>	<p>Replace empty Ink Tank(s). WARNING! Use proper procedure to replace Ink Tank(s) to avoid damage. See “Replacing the Ink Tanks” section.</p> <p>Select “Replace Ink Tanks”, then verify that Ink Tanks are seated firmly, and latches are fully closed.</p> <p>Verify that the printer is on a stable, level surface. Try to clear the error by pressing the “Refresh Ink Levels” button, located in the Toolbox.</p>
<p>CARTRIDGE_MISSING_X</p> 	<p>X = Color or MULTI Missing Ink Tank, or Ink Tank not being recognized</p>	<p>Replace Ink Tank(s) using proper procedure. Insert missing Ink Tank. Clean Ink Tank contacts as outlined in “Operator Maintenance” section. Clear error by pressing the “Refresh Ink Levels” button in the Toolbox.</p>

Toolbox System Status Messages (continued)

SYSTEM STATUS	PROBLEM	SOLUTION
DOOROPEN_FRONT	Printer has detected that the “Clamshell” is open.	Verify that the “Clamshell” is closed and securely latched at both sides. If closed, contact Service to check latch & switch. <i>Service Tech - if problem occurs after firmware is updated on a Z2i engine, please contact tech support to obtain “Z2i default script”.</i>
MAINTENANCE_BUSY	Printer is performing maintenance.	No action is required. Wait for printer to finish.
	Printer is waiting to perform maintenance, if error is shown in combination with “Reason: Uncapped printhead or clamshell open” and there is no maintenance activity (noise) coming from printer.	Remove media from print engine. See “Paperpath_Paperjam” solutions. If problem continues clean Paperpath Entry and Exit sensors. NOTE: Selecting “Ignore Exit Sensor”, in the Toolbox, will <u>not</u> solve issues caused by a non-responsive Exit Sensor. If problem continues contact Service.
System Status: ONLINE Reason: Uncapped printhead or clamshell open	This condition will be displayed after the Service Station is ejected (using the Eject Service Station button).	Re-install the Service Station (as outlined in this manual)
DATA_PATH_UNDERRUN	Media is not making it from the entry sensor to the exit sensor in the appropriated time. Possible issue with format or orientation of job being sent. Dirty Encoder Wheel	Check/clean transport rollers. Check/clean sensors. Try changing the orientation setting in the software/driver or setting a different media size. Check/clean the Encoder Wheel. If problem persists, contact technical support.
[Crit 63 03-phhead offline cancelpage restart]	Dirty Printhead contacts. Printhead or Pen Board fault.	Eject Printhead and inspect/clean contacts. Replace Printhead Call for Service Support.
PRINTHEAD_MISSING	Printer is still initializing, or some other issue is keeping it from fully initializing.	If printer was just powered on, or printhead was just installed, wait a few minutes, error should clear by itself. Call for Service Support.
PRINTHEAD_MISSINGQA	No printhead installed or printhead not making proper connections.	Install Printhead Cartridge. Remove printhead and check/clean contacts, then reinstall printhead. Replace printhead. Refer the appropriate sections in this manual for removing and installing the printhead cartridge.

**SECTION 6
TROUBLESHOOTING**

Toolbox System Status Messages (continued)

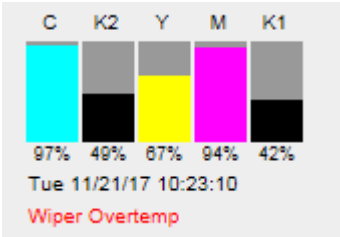
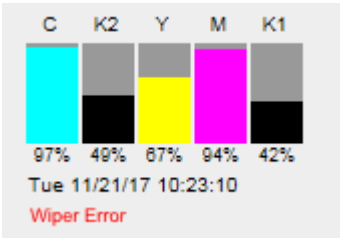
SYSTEM STATUS	PROBLEM	SOLUTION
PRINthead_UNPRIMED	Printhead priming process has not complete or has failed. Ink delivery issue.	If just powered on, or Tanks/Printhead just installed, wait a few minutes, error may clear by itself. Replace missing/empty Ink Tanks or Tanks that are reading less than 30%. Check for kinked or pinched ink tubes (Antistatic Brush Assembly may be pinching tubes). Release Printhead and reinstall, using proper techniques.
MECH_CANCELPAGE	Job was canceled by user pressing the CANCEL button. Job was interrupted by “Clamshell” being momentarily opened.	Wait until print job has cleared from printer. Then manually clear job from computer’s print queue. Then send new print job. Check to be sure “Clamshell” is securely latched, and then press “Clear Error” button to continue. If problem continues contact service support.
MECH_FAIL_PERMANENT Reason: Sled lift failed Reason: Ink valve failed Reason: Sled home failed	Mechanical failure or sensor failure. One of the printer’s mechanical components was not properly registered at the expected position.	If the Service Station was just installed, check to be sure it was installed properly. If problem persists, call for Service Support.
WIPER OVERTEMP 	Wiper Motor is overheated due to performing a Wiper Transfer (<i>removing excess ink off Service Station Wiper</i>) too often or for multiple or extended periods. Printer will continue maintenance after Wiper Motor cools down. Message will disappear once the temperature returns to operating range.	Wait for Wiper Motor to cool down , Printer will automatically resume operation. NOTE: If running several short jobs or jobs on smaller media, reset Mid-Job Servicing interval to a higher number of pages.
WIPER ERROR 	Wiper Roller is not turning. This can be due to: 1. White flex cable is dirty, broken or not connected. 2. Wiper Module (motor) failure. 3. DPCA failed at J17 terminal.	1. Check white flex cable and connections. 2. Replace Wiper Module. 3. Check and/or replace DPCA board.

Appendix A – Printer Specifications

SPEED (color or mono) Page Printing 8.5" x 11" No. 10 Envelopes	Up to 3,600 per hour (1600 x 800 dpi @ 12 ips) Up to 7,500 per hour (1600 x 800 dpi @ 12 ips)
PRINT AREA	8.77" W x 17" L (222.8 mm x 431.8 mm) – including bleed area Printer driver and firmware will accept up to a 30" height (length), but the Rear Media Support Guide will not support media over 17" long.
MEDIA SIZE	Minimum: 3" W X 4.125" L (76.2 mm x 104.76 mm) Maximum: 9.5" W x 17" L (241.3 mm x 431.8 mm)
MEDIA THICKNESS	Minimum: 0.004" (0.102 mm) Maximum: 0.02" (0.5 mm / 430 gsm)
PRINT QUALITY	Normal: 1600 x 800 DPI @ 12 ips Best: 1600 x 1600 DPI @ 6 ips
TECHNOLOGY	Memjet® Thermal Inkjet
INK CAPACITY	Cyan (250 ml), Yellow (250 ml), Magenta (250 ml), Black (500 ml)
COLOR MATRIX	Up to 16.8 million colors
FEEDER	Top Loading Friction Feeder Built-In.
PC INTERFACE	USB 2.0, Ethernet
FIRMWARE UPDATE	Electronic Download via PC connection
TRANSPORT	Pressure roller system with Star Rollers
FEATURES	Full color inkjet, fixed head design, high-capacity ink tanks, automatic printhead cleaning and capping service station.
FONTS	All available TrueType fonts
DIMENSIONS (approximate)	21" W x 24" L x 14.5" H - body only 21" W x 31" L x 21" H - including guides
WEIGHT	90 lbs. (40.9 kg)
ELECTRICAL	100-240 VAC, 50/60 Hz
FUSE	2.5A, 250V, slow blow
OPTIONS	Conveyor & IR Dryers, Bulk Mailer Software

All Specifications Subject to Change Without Notice

Operation should take place under the following conditions:

- At temperatures between +15°C and +30°C (59 °F to 86 °F).
With max temperature change of +/- 0.5°C (+/- 0.9°F) per minute.
- At a relative air humidity between 20% and 80%, non-condensing.
- At an atmospheric pressure between 70 kPa and 105 kPa.
- Printer and Print Engine should be protected from excessive environmental debris/dust.
- Printer must be placed on a "Sturdy/Level" surface.

Exposure to conditions that are not permissible may lead to damage which is not externally visible.
Allow the printer, printhead and ink tanks to acclimate to ambient temperature before using the printer.

Appendix B – Supplies and Optional Hardware

The following supply items and optional hardware are available from your Dealer/Distributor:

Supplies

DESCRIPTION	PART #
Printhead Cartridge	M5 PRINT
Wiper Roller	123-2480
Cyan Ink Tank (250 ml)	M5 C250
Magenta Ink Tank (250 ml)	M5 M250
Yellow Ink Tank (250 ml)	M5 Y250
Black Ink Tank (250 ml) - printer requires two	M5 K250
Waste Ink Tray Pad (pad only)	123-2491
Waste Ink Tray (Tray with absorbent pad material)	123-2487

Optional Hardware

Conveyor /Stacker with Drop Tray

NOTE: The use of a conveyor is highly recommended.

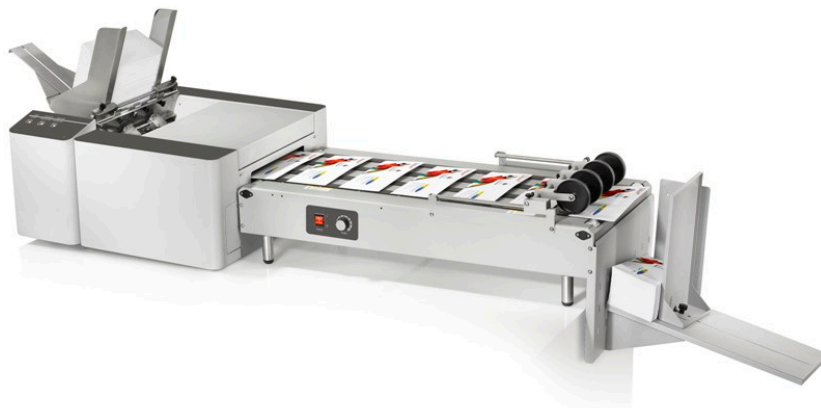

MACH 5 printer with optional conveyor/stacker, shown above.

Obtaining Supplies, Service and Support

Please contact your local Dealer/Distributor to obtain supplies, service, and support for your printer. To locate a Dealer/Distributor, in your area, please use the information available on the web site. Service should only be performed by qualified Service Personnel.

Appendix C – Quick Reference Info

Suggestion: Printout these quick reference sheets and attach to, or hang near, the printer.

Control Panel Light Sequences – Quick Reference

Valid with Firmware 20151228 or higher installed.

The lights (LED's), on the three control panel buttons, indicate the status of the printer.

Flashing SLOW = 1 time per second

Flashing FAST = 3 times per second

NOTE: To obtain additional details about the printer's condition, please refer to the section in the operations manual titled "Printer Status Light Indicators" and or open the Toolbox utility. You can also refer to "Errors and Warnings" for Additional Troubleshooting information.



LED Sequence	Printer Status	Recommended Action
	Print engine is powered-OFF	Safe to turn Main Power OFF or ON. NOTE: For best system performance, it is recommended to always keep the print engine powered-up.
ON, Steady 	Powered-up and Ready	Load Media & Send Job
Flashing, simultaneously 	Powering up or Shutting down	Wait for process to finish
ON, Steady Flashing SLOW, simultaneously 	Busy Condition: Performing Maintenance, Loading Data Canceling Job (CANCEL pressed)	Wait for process to finish
ON, Steady Flashing, alternating 	Printing	Wait for process to finish or Press PAUSE to pause printing
ON, Steady Flashing SLOW 	Printer Paused (PAUSE pressed)	Press RESUME to resume printing or CANCEL to clear job
ON, Steady Flashing FAST 	Out of Paper (Paper Time-Out), Change in Paper Length detected	Check/Set paper feed. Clean Feed Sensor. Reload Media, then press RESUME to resume printing, or CANCEL to clear job
ON, Steady ON, Steady 	Ink Supply Error: Ink Out, Missing Ink Tank, Printhead Unprimed	Use proper procedure to install/replace Ink Tanks(s) and then press RESUME button to resume printing
ON, Steady ON, Steady 	Paper Jam or one of the Paperpath sensors is covered or dirty	Open Clamshell and remove media or clean sensors. Press RESUME to resume printing, or CANCEL to clear job
ON, Steady Flashing FAST, simultaneously 	Hardware Error: Door (Clamshell) Open, Service Station movement issue, Printhead missing, etc.	Open Toolbox to help identify and fix issue

APPENDICES

Driver Properties Printing Adjustments - Quick Reference

These features are located under the **Layout** tab of the **M-Series Driver**

Left Adjustment - Moves the image area, left or right on the media.

Range: -2.98mm left to +200.02mm right. Default = 0

Top Adjustment - Moves the image up or down on the media.

Range: -4.95mm up to +200.02mm down. Default = 0

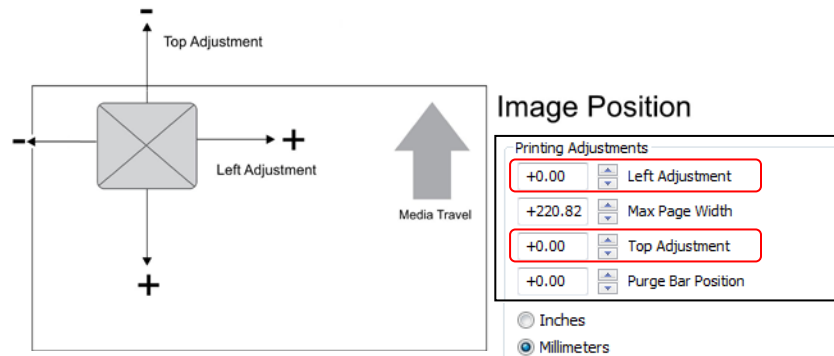

Max Page Width – Lets you set how wide the actual print area will be.

Reducing this value from 220.82mm will reduce the max print width of the printer.

Range: +0.5mm to +220.82mm. Default = 220.82 (max print width of printer)

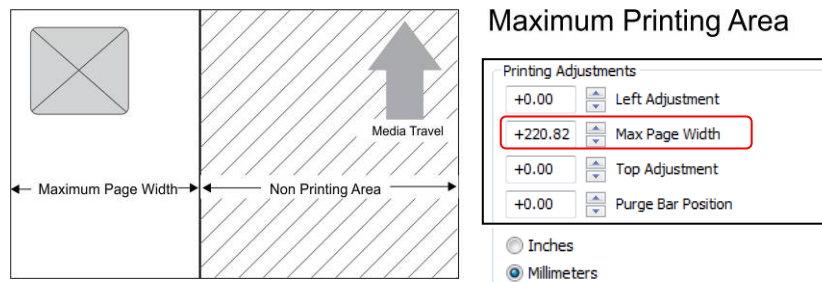

Purge Bar Position* – Allows you to adjust the purge bar location, to account for the extra length needed to reach the actual gap between pieces.

Range: -53.75mm up to +200.02mm down. Default = 0

* See also “**Purge Bar Position**” in the **Toolbox Features** section. Values are cumulative.

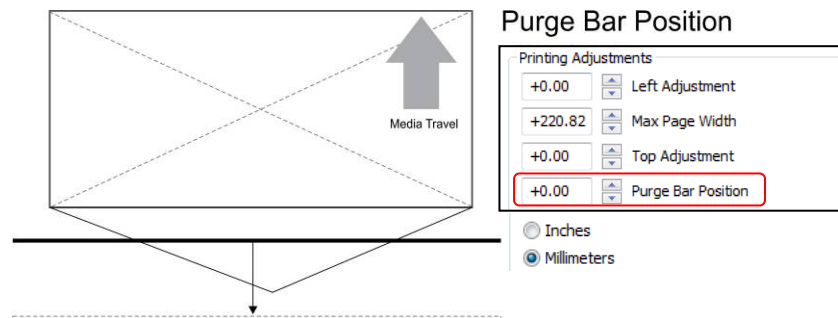

A		Distorted Print	114
Accessory Box Contents	14	Drop-Down Menu	47
Adjustable Media Side Guide	6, 14	View	47
Adobe Acrobat.....	65	E	
Adobe Reader.....	65	Envelope Printing Attachment Kit	35
Air in Nozzles	109	Error Messages	122
Antistatic Brush Assembly	8	F	
B		Feed Rollers	7
Bulk Mailer	67	Feed Setup.....	38
C		Firmware Download	51
Cartridge		Fuse.....	7, 127
Conditioning	63	Fuzzy Print	114
Printhead	8	H	
Clamshell Latches	8	Head Media Guide	35
Cleaning		I	
Capping Station Lip.....	85	IMPORTANT	39
Capping Station Lip.....	102	Indicators, Control Panel	10
Feed Rollers & Forwarding Rollers	100	Ink Revolver Couplings	8
Feed Sensor	101	Ink Revolvers.....	104
Grit Rollers.....	102	Ink Tank Anatomy.....	25
Ink Revolvers	104	Ink Tank Door.....	6
Ink Tank Contacts	77	Ink Tanks	9, 14, 74
Ink Tank Prism	77	Cleaning	77
Media Sensors	102	Disposal.....	79, 85
Paperpath Sensors.....	102	Latches.....	9
Paperpath Surfaces.....	102	Service Life.....	79
Print Engine	102	Storage.....	79
Printer Body.....	99	Troubleshooting.....	115
Printhead	80	Inspecting Waste Ink Tray.....	96
Printing Platen Surface	102	Installing	
Service Station	87	Choose Location	12
Wiper Motor Assembly	90	Ink Tanks	25, 26
Clearing Media Jams.....	98	Media Guides & Support	16
Clogged Nozzles.....	110	PPS Spacers.....	37
Color Mixing	111	Printer.....	11
Computer Connection	19	Printer Driver	56
Connection		Printhead Cartridge	29, 31
Network.....	7	Rear Media Support Guide	17
USB	7, 22	Service Station	92
Contents, Accessory Box	14	Tools Needed.....	11
Control Panel	6	Unpacking	13
Control Panel Functions	10	L	
Counter, LCD.....	7	Latch	
D		Clamshell	8
Damaged Nozzles	110	Printhead	8
Date and Time, Toolbox	56	Latches	
Disposal, Ink Tanks	79, 85		

INDEX

Ink Tank	9	Release Button.....	8
M		Remove/Replace.....	83
Maintenance	74	Service Life	84
Wiper Roller Inspection	86	Storage.....	84
Media Jams, Clearing.....	98	Printing	
Media Registration Side Guide	6, 14	Adobe Acrobat/Reader	65
Media Support Wedge	6	Bulk Mailer	67
Minimum Requirements, System	20	PDF.....	65
N		Protective Packaging	29
Narrow Media Support Wedge	14	Q	
Network Connection	19	Quick Reference	
Network Settings, Toolbox	56	Control Panel Light Sequences	129
O		Driver Properties Printing Adjustments.....	130
Obtaining Supplies, Service, and Support.....	128	R	
Operation CD	14	Rear Media Guide	14
Optional Hardware	128	Rear Media Support Guide	6
P		Relocation	
Paper/Resume Button, Control Panel	10	Local.....	106
Pause/Cancel Button, Control Panel	10	Remote	106
Power		Removing	
Button, Control Panel	10	Media Jams	98
Connection	7	PPS Spacers.....	37
Cord	14	Shipping Insert.....	15
Switch	7	Shipping Tape	15
PPS Spacers.....	37	Replacing	
Preparing Printer for Transport.....	106	Ink Tanks	74
Print Engine	8	Ink Waste Tray	96
Cleaning	102	Printhead Cartridge	83
Ink Revolvers	104	Service Station	87
Print Ink Channels Button.....	8	Sheet Separators	97
Printer		S	
Connection	18	Safety Precautions	2
Installing	11	Scan Sensors, Toolbox	58
Specifications.....	127	Scuff Marks	112
Transport Prep.....	106	Service	128
Printer Driver		Service Life	
Install	20, 56	Ink Tank	79
Properties	41	Printhead	84
Printer Toolbox		Service Station	9, 14
Drop-Down Menu.....	47	Cleaning	87
Scan Sensors	58	Installing	92
System Settings	56	Replacing	87
System Status	48	Setup	
User Interface	49	Feed	38
Printhead		Network Settings	56
Cartridge	8, 14	Sheet Separators	39
Cartridge Conditioning	63	Sheet Separators	7
Cleaning	80	Locking Knob.....	6
Install	31	Replacing	97
		Shipping Insert, Removing	15

Shipping Tape, Removing	15	Printhead Cartridge	116
Side Guide Locking Knob	6	Service Station Problems	119
Smudging	112	The Printer	118
Software Setup Info	64		
Specifications	127	U	
Storage		Uninstall	
Ink Tanks	79	Printer Driver	20
Printhead	84	Printer Software	20
Supplies	128	Toolbox Utility	20
Support	128	Unpacking	13
System Requirements, Minimum	20	USB Connection	19
System Settings, Toolbox	56	USB Flash Drive	14
System Status, Toolbox	48	USB Port	7, 19, 22
		User Interface, Toolbox	49
T			
Top Cover	6	V	
Transport Inspection	11	View, Drop-Down Menu	47
Transporting Printer	106		
Troubleshooting		W	
Communication Problems	120	Warning Messages	122
Errors and Warnings	122	Waste Ink Tray	9
Feeding Problems	121	Waste Ink Tray, Inspecting	96
Ink Tanks	115	Wide Media Support Wedge	14
Power Problems	118		
Print Quality Issues	108		

quadi⁷ent
Because connections matter.