

SPECTRUM

40

60

3D

VMI's Spectrum 6040 3D has technology capable of producing perspectives that capture the depth and detail of inspected volumes. Our innovative 3D perspective generation technology eliminates blind spots and increases visibility for easier threat identification. The Spectrum 6040 3D increases the efficiency of inspection procedures without changing the operating routine.



SECURITY

For a safer world

SPECTRUM 6040 3D

GENERAL DATA

- Dimensions:
1960(L) / 926(W) / 1432(H) [mm]
77,166" (L) / 36,457" (W) / 56,38" (H)
- Weight:
460kg / 1014,13lbs
- Operating temperature and humidity:
0°C to 40°C / 5% to 95%
(non-condensing)
- Storage temperature and humidity:
-40°C to 60°C / 5% to 95%
(non-condensing)
- Power supply:
110 - 127VAC / 208 - 240VAC
(-15% to +10%); 50Hz/60Hz, +/-3Hz
- Power:
740VA

GENERAL SPECIFICATIONS

- Tunnel dimensions:
620mm (W) / 420mm (H)
24,41" (W) / 16,536" (H)
- Conveyor speed:
0,22m/s (configurable)
- Conveyor height:
812mm / 31,97"
- Maximum load on the conveyor:
- Standard generator:
160 kV operating at 150 kV
- High Power Generator
180kV operating at 170 kV
- Wire resolution*:
40AWG
- Steel penetration*
42mm | 1.6" (150kV)
44mm | 1.7" (170kV)
- Monitor:
High resolution
(configurable size)
- Cooling:
Insulating oil with forced
air cooling
- Beam orientation:
Diagonal upward,
3D Perspective

* Specification according to Test Piece VMI

STANDARD FUNCTIONS

- Automatic discrimination of organic, inorganic and mixed materials by colorization
- Automatic image saving
- Baggage counter
- Continuous scanning
- Zoom higher than 128x
- Color or black / white image
- Edge highlight
- High penetration function
- Sharpness
- TIP threat image projection
- High density alert
- JPG, TIFF, BMP and VMI image export
- Network connection
- Real-time scanning
- Self-diagnosis system
- Color inversion
- Real-time image manipulation
- Automatic detection algorithm for drugs, explosives and high density materials
- Storage capacity over 200,000 images

SAFETY

- Shielding:
Dose below 1 μ Sv/h at 0.1m distance from the equipment in accordance with regulatory position CNEN 3.01 / 001: 2011

OPTIONAL FUNCTIONS AND ACCESSORIES

- Customized painting
- Training software
- Local language
- Remote workstation
- ASTM standard test kit
- Modular roller table
- Lockable anti theft console with key
- Remote management software for multiple devices
- Camera
- Tunnel protection extension
- UPS
- Ability to integrate with conveyor system
- WiFi capability
- Integration with Garrett's walk-through metal detector portals
- ONVIF compatibility

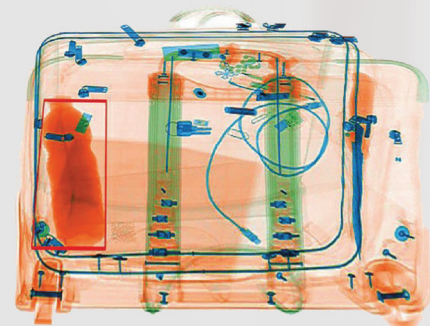
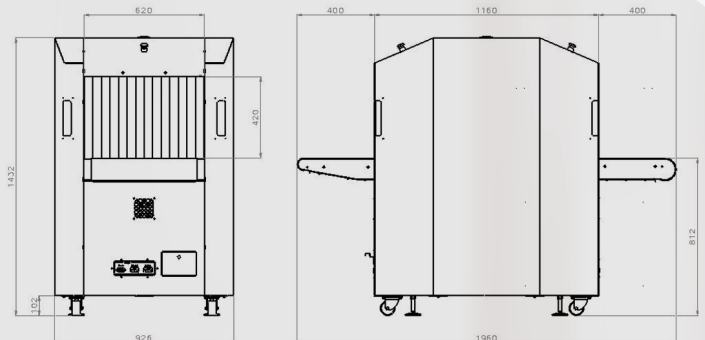

VMI SECURITY

R. Um, 55 - Distrito Industrial Genesco Aparecido de Oliveira
Lagoa Santa / MG - Brazil - ZIP CODE: 33.240-094

Telephone: +55 (31) 3622-0470 / 3622-0124

www.vmisecurity.com

X-RAY SCANNERS

